



CONTEMPORARY STREET FURNITURE DESIGN

2025 CALZOLARI



CALZOLARIARREDOURBANO.EU



CONTEMPORARY STREET FURNITURE DESIGN 2025

FOR 60 YEARS
IN URBAN FURNISHINGS

DA 60 ANNI NELL'ARREDO URBANO

Da 60 anni qualità, design, innovazione caratterizzano i prodotti Calzolari.

Player importante nel settore dell'Arredo Urbano in pietra ricostruita, attraverso l'adozione di tecnologie sostenibili, Calzolari combina - con professionalità e passione - l'alto standard qualitativo di ogni pezzo prodotto con la dedizione dei maestri artigiani italiani e le linee del design contemporaneo.

For 60 years quality, design and innovation have characterized Calzolari products.

An important player in the sector of street furniture in reconstructed stone, through the adoption of sustainable technologies, Calzolari combines the high quality standard of each piece produced with the fine craft of italian masters and exceptional style and innovation.



DESIGN: MCA MARIO CUCINELLA ARCHITECTS

GINKO SYSTEM



IL SISTEMA GINKO PRENDE ISPIRAZIONE DALL'ICONICA FOGLIA DEL GINKGO BILOBA. È UN SISTEMA DI SEDUTE COMPOSTO DA UN MODULO PANCHINA E UN MODULO FIORIERA.

GLI ELEMENTI PERMETTONO DI CREARE INFINITE CONFIGURAZIONI FACENDO DIALOGARE LO SPAZIO DI SEDUTA CON LA POSSIBILITÀ DI INTEGRAZIONE DEL VERDE. LA COLLEZIONE GINKO SUGGERISCE UN NUOVO MODO DI UTILIZZO DELLA SEDUTA CONSENTENDONE UN USO INFORMALE E SEMPRE DIVERSO.

LA SUA COMPONIBILITÀ LO RENDE UN SISTEMA FLESSIBILE E ADATTABILE A DIVERSI SPAZI.

THE GINKO SYSTEM TAKES ITS INSPIRATION FROM THE ICONIC GINKGO BILOBA LEAF.

IT IS A SEATING SYSTEM COMPOSED OF A BENCH MODULE AND A PLANTER MODULE.

THE ELEMENTS ALLOW FOR INFINITE CONFIGURATIONS BY MAKING THE SEATING SPACE DIALOGUE WITH THE POSSIBILITY OF INTEGRATING GREENERY. THE GINKO COLLECTION SUGGESTS A NEW WAY OF USING THE SEAT, ALLOWING IT TO BE USED INFORMALLY AND ALWAYS DIFFERENTLY.

ITS MODULARITY MAKES IT A FLEXIBLE SYSTEM THAT CAN BE ADAPTED TO DIFFERENT SPACES.

GINKGO SYSTEM

DESIGN: MCA MARIO CUCINELLA ARCHITECTS

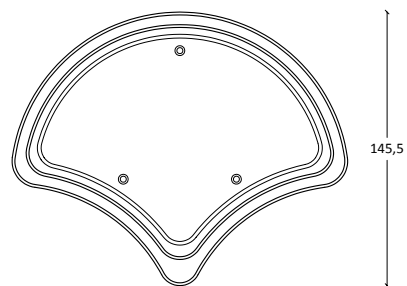
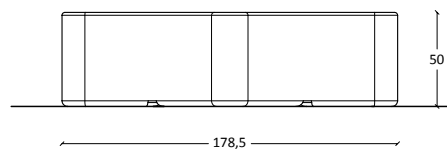
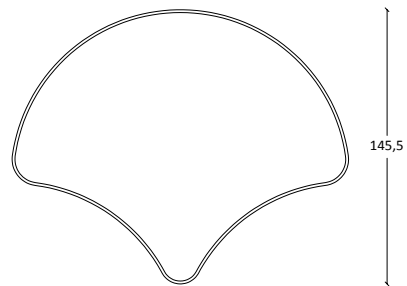
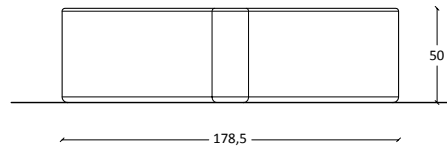

Mario Cucinella graduated in Architecture at the University of Genoa in 1986. In 1992, in Paris, he founded Mario Cucinella Architects, an architecture firm now based in Bologna and Milan. In 2015 he founded SOS - School of Sustainability, a postgraduate program focused on sustainable architecture. The importance of his work and continued commitment as an architect and educator on environmental and social issues have been recognized with the International Fellowship of the Royal Institute of British Architects (2016) and with the Honorary Fellowship of the American Institute of Architects (2017). In 2018, he was curator of the Italian Pavilion de La Biennale di Venezia, with the exhibition "Arcipelago Italia". On 20 June 2024, MCA - Mario Cucinella Architects received the ADI Compasso d'Oro Award for the 'Museo d'Arte Fondazione Luigi Rovati' project. He is the author of many publications.



Mario Cucinella si laurea in Architettura all'Università di Genova nel 1986. Nel 1992, a Parigi, fonda lo studio Mario Cucinella Architects, che oggi ha sede a Bologna e Milano. Nel 2015 Mario Cucinella fonda SOS - School of Sustainability, un programma postlaurea sui temi della sostenibilità. L'importanza del suo lavoro ed il continuo impegno, come architetto ed educatore, su tematiche ambientali e sociali, sono stati riconosciuti con la International Fellowship del Royal Institute of British Architects (2016) e con la Honorary Fellowship dell'American Institute of Architects (2017). Nel 2018 è stato curatore del Padiglione Italia alla Biennale di Venezia 2018 con la mostra "Arcipelago Italia". Il 20 giugno 2024 MCA - Mario Cucinella Architects ha ricevuto il Premio Compasso d'Oro ADI per il progetto "Museo d'Arte Fondazione Luigi Rovati". È autore di molte pubblicazioni.

- 05 **GINKO SYSTEM**
- 41 **BESPOKE DESIGN**
- 51 **PANCHINE | BENCHES**
- 53 ALTHEA
- 57 ANDROMEDA | ANDROMEDA STEEL
- 61 ANDROMEDA WOOD
- 63 ANDROMEDA STARS
- 65 ANDROMEDA MANGIA SMOG | "SMOG-EATER"
- 67 ANDROMEDA LIGHTING
- 69 ANDROMEDA CONNECT
- 71 SOLARIS SMART
- 72 ANDROMEDA CURVED
- 73 ANDROMEDA LARGE
- 75 AURIGA
- 77 CASSIOPEA
- 79 CIRCO
- 83 EOS
- 87 FOLIA
- 89 LITHOS | LITHOS CURVED
- 91 LITHOS WOOD
- 93 MEGA LITHOS
- 95 ROLLER
- 97 VEGA
- 99 HYDRA | ASTER
- 100 RONDO | GINESTRA
- 101 DALIA
- 103 PANCHINE CLASSICHE | SEATS FOR PARKS
- 105 DAPHNE
- 106 ANTARES
- 107 ARIES
- 108 ARGO
- 109 LEVANTE
- 110 AQUARIO | ARIETE
- 111 CENTAURA | CHAISE LONGUE
- 113 **FIORIERE | PLANTERS**
- 115 FIORIERE ANDROMEDA | ANDROMEDA PLANTERS
- 116 INTRECCI
- 117 FIORIERE IN CEMENTO | CONCRETE PLANTERS
- 119 FIORIERE IN ACCIAIO | STEEL PLANTERS
- 121 **COMPLEMENTI | OTHER FURNISHINGS**
- 123 DEVIATORI IN PIETRA RICOSTRUITA | CONCRETE BOLLARDS
- 129 BARRIERE ANTITERRORISMO | ANTI-TERRORISM BARRIERS
- 131 DEVIATORI IN METALLO | METAL BOLLARDS
- 135 TRANSENNE | SAFETY BARRIERS
- 137 CONTENITORI IN PIETRA RICOSTRUITA | CONCRETE LITTER BINS
- 141 SQUARE CESTONE GETTACARTE | SQUARE LITTER BIN
- 143 CONTENITORI IN METALLO | STEEL LITTER BINS
- 145 CESTINI GETTACARTE SU PALO | POLE-MOUNTED LITTER BINS
- 149 CONTENITORI IN ACCIAIO | STEEL LITTER BINS
- 150 POSACENERE | ASHTRAY
- 153 CESTINI RACCOLTA DIFFERENZIATA | RECYCLING LITTER BINS
- 157 BICISOSTA | BIKE RACKS
- 163 BIKE STATION
- 165 E-BIKE - IMPIANTI PER RICARICA | CHARGING STATIONS
- 166 PENSILINE E COVERBICI | BUS AND BIKE SHELTERS
- 167 GRIGLIE PER ALBERI | TREE GRILLES
- 168 DOG TOILET | DOG WASTE BINS
- 169 FONTANELLE | FOUNTAINS
- 171 TAVOLI | TABLES
- 172 ISOLA ECOLOGICA | PRIVACY SCREENS FOR LITTER BINS
- 173 TOTEM E BACHECHE | TOTEMS AND NOTICEBOARDS
- 175 **COLORI DISPONIBILI | AVAILABLE COLOURS**



ANDROMEDA BENCHES AND "H" LITTER BINS
PORTA A MARE SHOPPING CENTRE - LIVORNO (TUSCANY)



ANDROMEDA TABLES AND BENCHES
TE PARK - MANTOVA



ANDROMEDA TABLES AND BENCHES
KING EDWARD VI SCHOOL - BIRMINGHAM (UK)



FOLIA AND LITHOS BENCHES
DALLA CHIESA SQUARE (S.B. Arch.) - ARESE



ANDROMEDA BENCHES
BISENZIO WATERFRONT - PRATO



Countrywide

Marmalade Skies

MERCHANT SQUARE

ANDROMEDA PLANTERS
GLASGOW CITY CENTRE (UK)



LITHOS BENCHES
ATRIUM OFFICE DISTRICT (J+S Arch.) - PARMA



FOLIA BENCHES
VIALE REGINA MARGHERITA - ROMA



FOLIA AND ANDROMEDA BENCHES
WATERFRONT (Zaha Hadid Architects) - REGGIO CALABRIA



ANDROMEDA LIGHTING BENCHES
CENTRO IKEDA (Piuarch) - MILANO



LITHOS WOOD BENCHES + ANDROMEDA TABLES
ORLY AIRPORT - PARIS



CUSTOMIZED SEATS (Arch. Santiago Calatrava)
MEDIOPADANA RAILWAY STATION - REGGIO EMILIA

PIÙ
VITTORIOSO
DELLA STORIA

MOST
SUCCESSFUL
FERRARISTA
IN HISTORY



Museo Ferrari
MARANELLO

ANDROMEDA BENCHES
FERRARI RACING MUSEUM - MARANELLO



באיזור זה
הנישון
אסור בהחלט

CUSTOMIZED PLANTERS + EOS SEATS
TEL AVIV (ISRAEL)



SEATS AND BOLLARDS
COLOSSEO ARCHEOLOGICAL PARK - ROMA

BESPOKE DESIGN

IN 60 ANNI ABBIAMO MATURATO UNA GRANDE ESPERIENZA NELLA REALIZZAZIONE DI MANUFATTI PROGETTATI DAL COMMITTENTE SIA IN PIETRA RICOSTRUITA CHE IN ALTRI MATERIALI. DIAMO COSÌ CORPO ALLE IDEE DEL PROGETTISTA E VALORIZZIAMO LE SPECIFICHE IDENTITÀ DI CIASCUN LUOGO CREANDO MANUFATTI UNICI, FRUTTO DEI SAPERI E DELL'ABILITÀ ARTIGIANALE ITALIANA.

IN MORE THAN 60 YEARS OF EXPERIENCE, WE HAVE GAINED VALUABLE EXPERTISE IN CREATING BESPOKE STREET FURNITURE DESIGNED BY OUR CUSTOMERS AND MANUFACTURED BY OURSELVES FROM CONCRETE OR OTHER MATERIALS. BRINGING THE DESIGNER'S IDEAS TO LIFE, WE HELP SHAPE THE UNIQUE IDENTITY OF EACH PLACE THANKS TO OUR ONE-OF-A-KIND CREATIONS, THE FRUIT OF THE GREAT ITALIAN KNOW-HOW AND FINE CRAFTSMANSHIP.

PLANTERS AND SEATS
DIVERSIVO PARK (OKS Architetti) - GROSSETO



CUSTOMIZED PLANTERS AND SEATS
ANDERLECHT - BRUXELLES (BELGIUM)



STREET FURNITURE
SAN DOMENICO SQUARE (Arch. Barili e Arch. Gori) - PISTOIA



CUSTOM MEGA SEAT
CONTEMPORARY ART GALLERY (Arch. Maurice Nio) - PRATO



SEATS AND WALLS (Arch. Marescotti)
PADOVA



MEGA PLANTERS AND SEATS
SAN TERENZO WATERFRONT - LERICI

PANCHINE
BENCHES



ALTHEA

PANCHINA MONOBLOCCO DAL DESIGN ESSENZIALE MA DAI FORTI TRATTI DISTINTIVI.

SINGLE-BLOCK CONCRETE BENCH WITH A MINIMALIST YET STRIKING DESIGN WHICH FITS INTO ANY URBAN AREA.

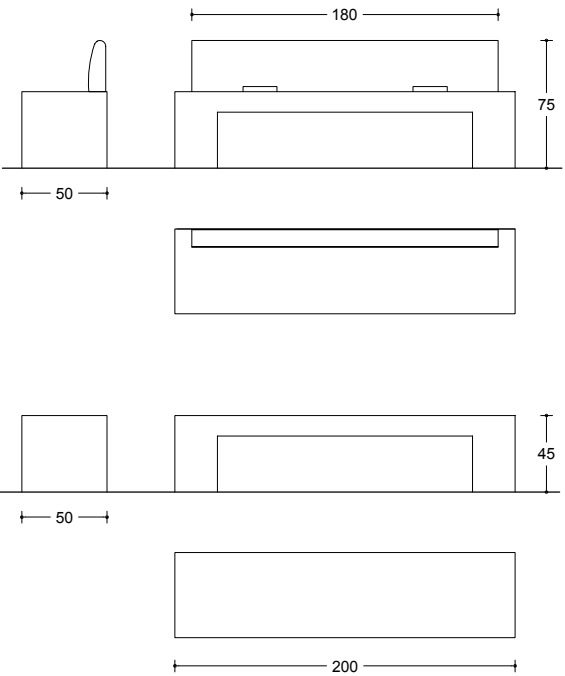

ALTHEA LIGHT



IL MANUFATTO VIENE PROPOSTO IN CEMENTO GRIGIO, BIANCO O CON RIVESTIMENTO ACRILICO COLORATO. SU RICHIESTA VIENE EQUIPPAGGIATO CON ILLUMINAZIONE LED.

THE BENCH IS AVAILABLE IN GREY OR WHITE CONCRETE OR COVERED WITH SOLID COLOUR ACRYLIC FINISH. LED LIGHTING AVAILABLE UPON REQUEST.

- CON SCHIENALE/WITH BACKREST
CM 200x50x75H- KG 580
- SENZA SCHIENALE/WITHOUT BACKREST
CM 200x50x45H- KG 460



ANDROMEDA BENCHES
EXPO 2015 MILANO

ANDROMEDA

SEDUTA CARATTERIZZATA DA SOLIDITÀ E RESISTENZA AGLI ATTI VANDALICI.

A SOLID BENCH HIGHLY RESISTANT TO WEATHER CONDITIONS AND VANDALISM.



CATTEDRALE- PALERMO

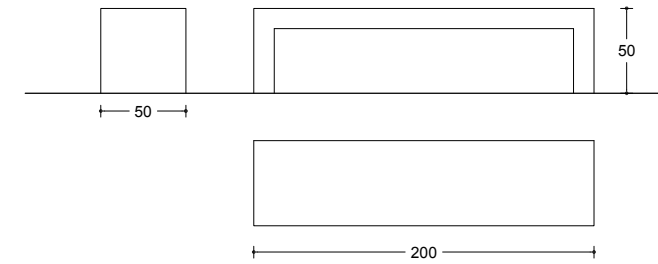

ANDROMEDA STEEL



OLTRE CHE NELLE VARIE COLORAZIONI STANDARD (CEMENTO GRIGIO, BIANCO E RIVESTIMENTO ACRILICO COLORATO), VIENE ANCHE PROPOSTA NELLA VERSIONE PIETRA RICOSTRUITA LEVIGATA DI COLORE NERO, BIANCO, ROSA, VERDE E GIALLO SIENA.

BESIDES THE STANDARD VERSIONS IN GREY OR WHITE CONCRETE AND COLOURED ACRYLIC COATING, THE BENCH IS ALSO AVAILABLE IN POLISHED RECONSTRUCTED STONE, AS PER OUR COLOUR CHART.

- CM 200x50x50H - KG 420
- CM 220x60x45H - KG 500
- CM 300x50x50H - KG 580

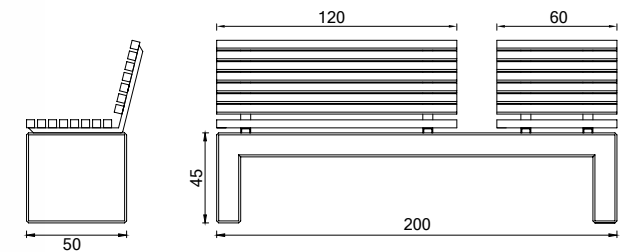



ANDROMEDA WOOD
SESTRI LEVANTE WATERFRONT - GENOVA

ANDROMEDA WOOD



VERSIONE CON ECOLEGNO
ECO WOOD VERSION



QUESTA VERSIONE DELLA PANCHINA ANDROMEDA UNISCE LE DOTI DI RESISTENZA DEL CONGLOMERATO CON IL COMFORT DELLA SEDUTA E SCHIENALE IN LEGNO (DISPONIBILE IN PINO, IN LEGNO ESOTICO O IN ECOLEGNO)

THIS VERSION COMBINES THE RESISTANCE AND DURABILITY OF REINFORCED CONCRETE WITH THE COMFORT AND WARMTH OF WOOD, ALSO AVAILABLE WITH A MATCHING BACKREST (PINE, EXOTIC OR ECO WOOD)

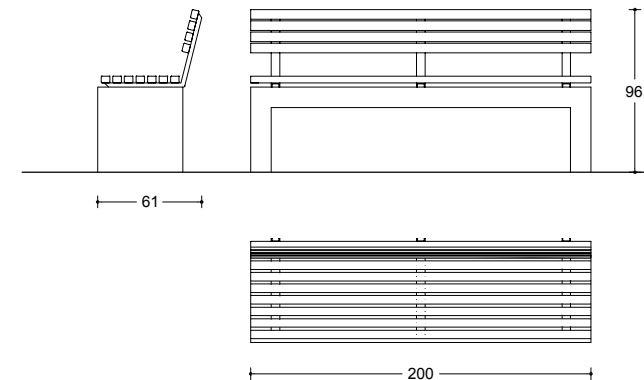

L'ALTEZZA DELLA SEDUTA È STATA STUDIATA PER FAVORIRNE L'UTILIZZO DA PARTE DI PERSONE ANZIANE O DISABILI.

THE WOODEN SEAT HAS BEEN STUDIED TO ALLOW EASY ACCESS TO ALL USERS, INCLUDING PEOPLE WITH DISABILITY OR IMPAIRED MOBILITY.

- SENZA SCHIENALE /WITHOUT BACKREST: CM.200x50x56,5H - KG.430
- CON SCHIENALE/WITH BACKREST: CM.200x61x96H - KG.440



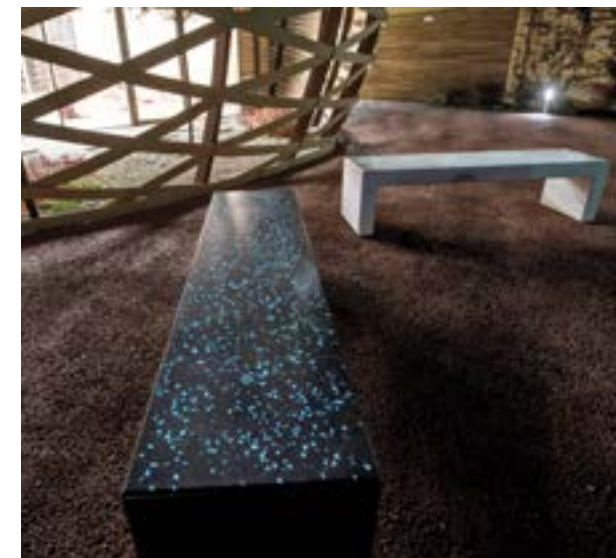

63

ANDROMEDA STARS

E' UNA PANCHINA DOTATA DI PARTICELLE LUMINESCENTI CHE, INTEGRATE NEL CONGLOMERATO, HANNO LA PROPRIETÀ DI ASSORBIRE LA LUCE SOLARE O ARTIFICIALE E DI RILASCIARLA NELLE ORE NOTTURNE.

THE SEAT OF THIS BENCH FEATURES LUMINESCENT PARTICLES, WHICH, INCORPORATED INTO THE CONCRETE SKIN, ABSORB NATURAL OR ARTIFICIAL LIGHT AND THEN RELEASE THE ENERGY IN THE FORM OF VISIBLE GREEN OR BLUE LIGHT IN THE DARK.



LA PERSISTENZA DELL'ILLUMINAZIONE È VARIABILE IN FUNZIONE DELL'IRRAGGIAMENTO RAGGIUNTO ED HA UNA DURATA INDICATIVA DI 4-6 ORE

THE GLOW CAN BE SEEN FOR 4 TO 6 HOURS DEPENDING ON THE AMOUNT OF ABSORBED LIGHT

ANDROMEDA MANGIASMOG “SMOG-EATER”

CINQUE PANCHINE EQUIVALGONO ALLA MESSA A DIMORA
DI UN ALBERO IN CITTA'

FIVE BENCHES EQUAL ONE TREE IN THE CITY CENTRE

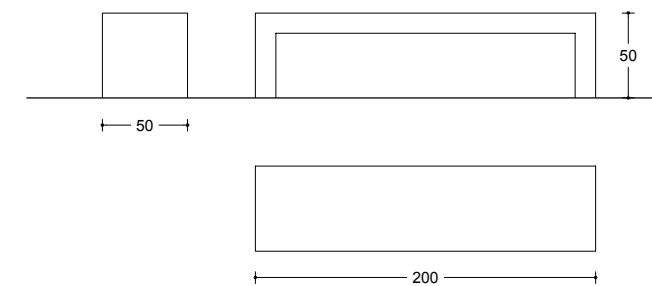

QUESTA PANCHINA È REALIZZATA CON UN CEMENTO FOTOCATALITICO CHE È IN GRADO DI ABBATTERE GLI INQUINANTI PRESENTI NELL'ARIA (OSSIDO DI AZOTO E POLVERI SOTTILI PM10). LA FOTOCATALISI È UN PROCESSO NATURALE CHE, SFRUTTANDO L'ENERGIA LUMINOSA, ACCELERA I PROCESSI DI OSSIDAZIONE GIÀ ESISTENTI IN NATURA FAVORENDO LA DECOMPOSIZIONE DEGLI INQUINANTI PRESENTI NELL'AMBIENTE. PROVE DI LABORATORIO EFFETTUATE SU EDIFICI O PAVIMENTAZIONI REALIZZATI CON QUESTO MATERIALE EVIDENZIANO UN MIGLIORAMENTO DELLA QUALITÀ DELL'ARIA IN AMBIENTI URBANI INQUINATI E CERTIFICANO INOLTRE CHE I MANUFATTI SONO PRESERVATI DAL DEGRADO NEL TEMPO CAUSATO DAGLI AGENTI ATMOSFERICI.

THIS SPECIAL VERSION OF ANDROMEDA BENCH IS MADE OF PHOTOCATALYTIC CONCRETE ABLE TO BREAK DOWN THE POLLUTANTS (NITROGEN OXIDE AND PM10) IN THE ATMOSPHERE. PHOTOCATALYSIS IS A NATURAL PROCESS THAT IN THE PRESENCE OF SUNLIGHT ACCELERATES OXIDATION PROCESSES ALREADY OCCURRING IN NATURE AND FAVOURS THE DECOMPOSITION OF ENVIRONMENTAL POLLUTANTS. LABORATORY TESTS CARRIED OUT ON BUILDINGS AND SURFACES MADE OF THIS MATERIAL SHOW AIR QUALITY IMPROVEMENT IN POLLUTED URBAN AREAS AND CERTIFY THAT, OVER TIME, THE SURFACES ARE PRESERVED FROM DETERIORATION CAUSED BY THE WEATHER AND ATMOSPHERIC CONDITIONS.

• CM.200x50x50H - KG 420

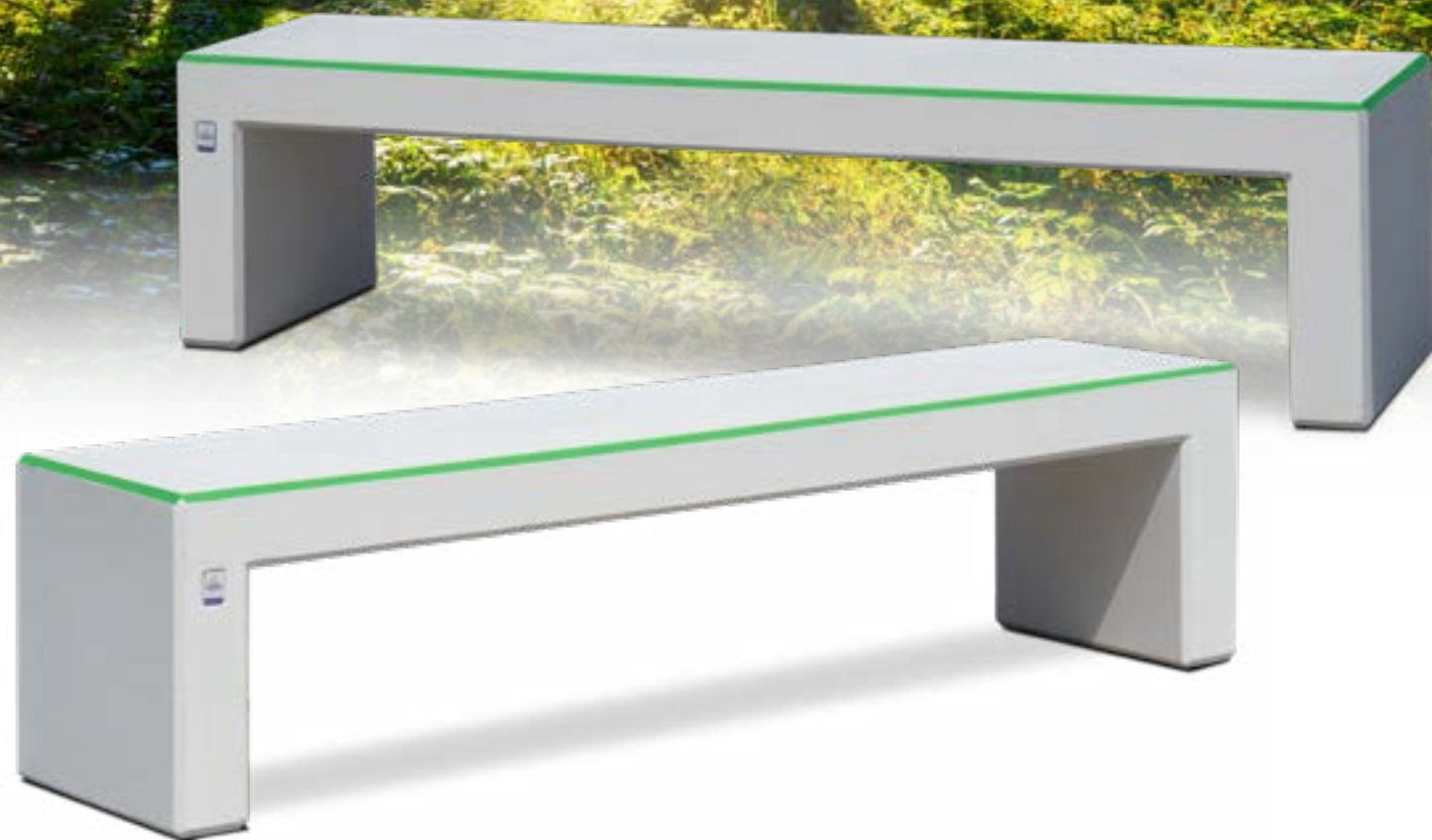



ANDROMEDA LIGHTING



VERSIONE CON TUBO LED | LED TUBE VERSION

- TUBO LED 23W - 230V - IP 65 - 4000K
- LED TUBE 23W - 230V - IP 65 - 4000K

QUESTA VERSIONE È DOTATA DI ILLUMINAZIONE INTEGRATA CON CORPO ILLUMINANTE LED E, INOLTRE, DI UNA SECONDA VERSIONE CON STRIP LED IN BASSA TENSIONE.

A SPECIAL VERSION OF THE ANDROMEDA BENCH EQUIPPED WITH A LED TUBE OR A LED STRIP.



VERSIONE CON STRIP LED | STRIP LED VERSION

- STRIP LED CM 100x1,7x0,8 (4000K)
- DOTATA DI ALIMENTATORE REMOTO (1 OGNI 3 STRIP LED)
- CON STRIP LED 14,4W - 24V DC
- LED STRIP CM 100x1,7x0,8 (4000K)
- WITH POWER TRANSFORMER (1 UNIT EVERY 3 LED STRIPS)
- LED STRIP 14.4 W - 24 V DC

LA VERSIONE LED CON ALIMENTAZIONE 230V È CERTIFICATA CE E COSTRUITA NEL RISPETTO DELLA NORMA EN 60598-1.

THE 230V LED LIGHTING SYSTEM IS CE CERTIFIED AND MEETS THE REQUIREMENTS OF THE EN 60598-1 STANDARD.





ANDROMEDA CONNECT

PANCHINA DOTATA DI CORPO ILLUMINANTE LED, DI UN GRUPPO TRE PRESE A TENUTA STAGNA (SCHUKO, USB E BIVALENTE) PER LA RICARICA DI DISPOSITIVI MOBILI E DI RIPETITORE WIFI.

THIS BENCH IS EQUIPPED WITH LED LIGHTING AS WELL AS WATERPROOF OUTDOOR SOCKETS TO RECHARGE MOBILE DEVICES AND WIFI REPEATER.



UN WIRELESS REPEATER CONSENTE DI AUMENTARE LA COPERTURA SENZA FILI PER TUTTE LE RETI WLAN. INSTALLANDO I RIPETITORI SU PIÙ PANCHINE È POSSIBILE CREARE UNA ZONA DOTATA DI COPERTURA COMPLETA DI SUPPORTO AL TRAFFICO WIRELESS MULTIMEDIALE.

ANDROMEDA CONNECT IS PROVIDED WITH A WIFI RANGE EXTENDER TO FURTHER BOOST THE WLAN SIGNAL. THIS OPTION CAN BE CHOSEN WHEN WANTING TO CREATE A FULLY CONNECTED WIFI OUTDOOR AREA.





SOLARIS SMART - BENEVENTO

SOLARIS SMART

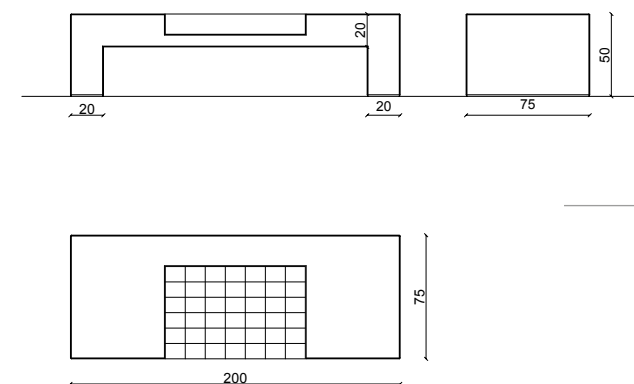

• CM.200X75XH.50 - KG 778

PANCHINA SENZA CABLAGGI ALLA RETE
QUESTA NUOVA PANCHINA È REALIZZATA CON UNA
STRUTTURA IN PIETRA RICOSTRUITA ED È DOTATA DI UN
MODULO FOTOVOLTAICO CHE LA RENDE INDIPENDENTE DALLA
RETE DI ALIMENTAZIONE ELETTRICA.

OFF-GRID SMART CONCRETE BENCH
A ROBUST BENCH IN RECONSTRUCTED STONE EQUIPPED WITH
A PV SOLAR PANEL MAKING IT COMPLETELY INDEPENDENT
FROM THE NATIONAL ENERGY GRID.

IL MODULO FOTOVOLTAICO MONOCRISTALLINO DI POTENZA 60W ALIMENTA:

- 2 PRESE USB PER RICARICA DI DISPOSITIVI FINO A 2 A E RICARICA WIRELESS
- ILLUMINAZIONE LED RIVOLTA A TERRA DA 20W 6000K
- SENSORI TEMPERATURA E UMIDITÀ AMBIENTE ESTERNO
- SISTEMA DI RAFFREDDAMENTO INTERNO
- BATTERIA AGM DA 0,36 KWH
- ACCESSO TRAMITE WIFI AD INTERFACCIA PER VISUALIZZAZIONE DATI E CONTROLLO REMOTO
- TRASFORMATORE PER RICARICA DI BACKUP 230V AC
- PROTEZIONE ELETTRICA: IP67

SOLARIS SMART NON RICHIEDE FISSAGGIO A TERRA E CONCILIA LA RESISTENZA AGLI ATTI VANDALICI E LA DURATA NEL TEMPO TIPICA DEI PRODOTTI IN PIETRA RICOSTRUITA CON L'INNOVAZIONE DI UN MODULO TECNOLOGICO COMPLETAMENTE INDIPENDENTE.

THE 60W MONOCRISTALLINE SOLAR PV MODULE POWERS:

- 2 USB CHARGING SOCKETS FOR DEVICES UP TO 2A AND 1 WIRELESS CHARGING PAD
- GROUND-FACING 20W LED LIGHT 6000K
- OUTDOOR TEMPERATURE AND HUMIDITY SENSORS
- INCORPORATED COOLING SYSTEM
- 0.36 KWH AGM BATTERY
- ACCESS TO THE INTERFACE FOR REMOTE CONTROL AND DATA MONITORING
- TRANSFORMER FOR 230V AC BACKUP CHARGING
- IP67 ENCLOSURE RATING

SOLARIS SMART IS A FREE STANDING BENCH THAT DOES NOT REQUIRE GROUND FIXING. THE BENCH COMBINES VANDAL-RESISTANCE AND DURABILITY TYPICAL OF THE RECONSTRUCTED STONE PRODUCTS WITH THE INNOVATION OF A GRID-INDEPENDENT TECHNOLOGICAL SOLUTION.



MODULO FOTOVOLTAICO MONOCRISTALLINO
MONOCRISTALLINE PHOTOVOLTAIC MODULE

72



ANDROMEDA CURVED



- OGNI ELEMENTO / EACH UNIT
CM 203x90x45H (KG 650)
- RAGGIO ESTERNO / EXTERNAL RADIUS CM 481

73

ANDROMEDA LARGE



VERSIONE EXTRA LARGE DELLA PANCHINA ANDROMEDA CARATTERIZZATA DA SOLIDITÀ E RESISTENZA AGLI ATTI VANDALICI. LA SEDUTA VIENE PROPOSTA NELLE VARIE COLORAZIONI STANDARD.

EXTRA LONG VERSION OF THE BESTSELLING ANDROMEDA BENCH. ALL STANDARD COLOURS AVAILABLE.

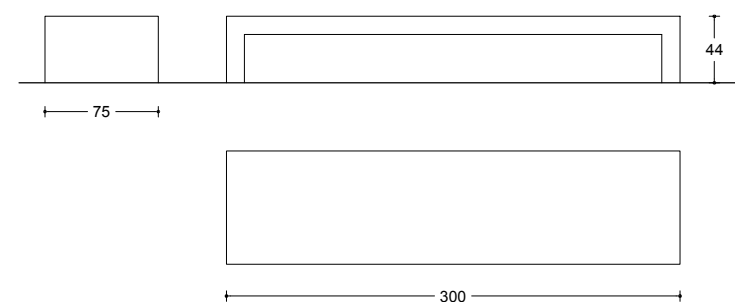

- CM 300x75x44H - KG 780
- CM 300x75x50.5H - KG 800
(SEDUTA RIVESTITA IN LEGNO PINO O ESOTICO/PINE OR EXOTIC WOOD SEAT)



AURIGA

DESIGN SERGIO RAIMONDO

MODELLO COSTITUITO DA UNA SOLIDA STRUTTURA PORTANTE IN CONGLOMERATO CEMENTIZIO, ABBINATO AD UNA SEDUTA IN LEGNO ESOTICO, DISPONIBILE CON O SENZA SCHIENALE.

SOLID REINFORCED CONCRETE BENCH COMBINED WITH A COMFORTABLE SLATTED SEAT IN EXOTIC WOOD, AVAILABLE WITH OR WITHOUT BACKREST.

AURIGA BENCHES
GLASGOW (UK)

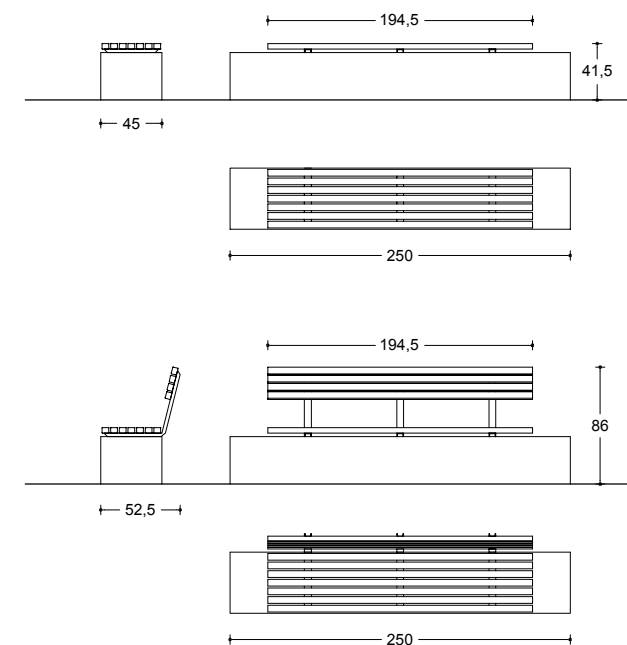

LA SEDUTA IN CEMENTO PUÒ ESSERE REALIZZATA NELLE COLORAZIONI STANDARD (GRIGIO O BIANCO) O CON RIVESTIMENTO ACRILICO, MENTRE IL SEDILE IN LEGNO ESOTICO È DISPONIBILE IN COLOR NOCE.

THE CONCRETE BENCH IS AVAILABLE IN STANDARD COLOURS (GREY OR WHITE) OR WITH ACRYLIC COATING, WHILE THE SEATING IS AVAILABLE ONLY IN EXOTIC WOOD.

- SENZA SCHIENALE/WITHOUT BACKREST: CM 250x45x41.5H - KG 720
- CON SCHIENALE/WITH BACKREST: CM 250x52,5x86H - KG 730

CASSIOPEA



SEDUTA MONOBLOCCO IN PIETRA RICOSTRUITA CHE NON RICHIEDE FISSAGGIO A TERRA.

FREESTANDING SEAT IN FAIR-FACED GREY CONCRETE WITH WOODEN TOP.

PRODOTTA NELLA COLORAZIONE GRIGIO NATURALE CON RIVESTIMENTO DI SEDUTA IN LEGNO DI PINO IMPREGNATO IN AUTOCLAVE OPPURE IN LEGNO ESOTICO. OPTIONAL: TUBO LED CM. 150 - 23W - 230V - IP65

AVAILABLE IN NATURAL GREY CONCRETE WITH WOODEN SEAT MADE OF VACUUM-PRESSURE IMPREGNATED PINE WOOD OR EXOTIC WOOD. OPTIONAL: LED TUBE CM. 150 - 23W - 230V - IP65

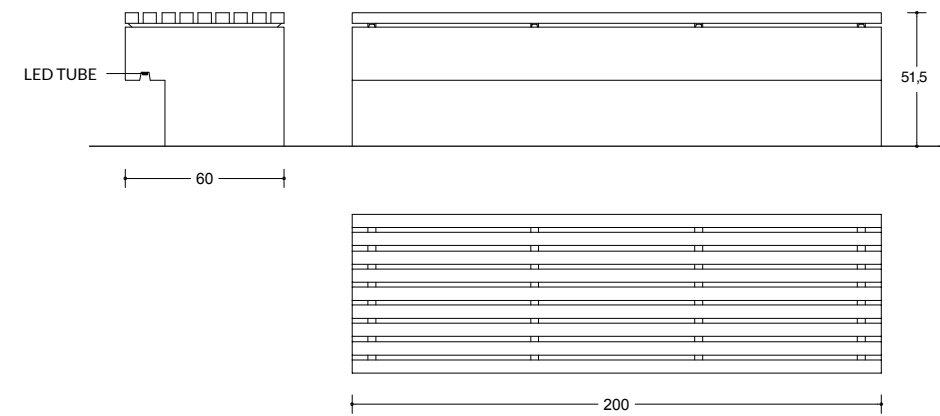

• CM 200x60x51,5H - KG 1100



SMARTPARK - ATHENS (GREECE)



CIRCO

DESIGN CRISTIANO TORALDO DI FRANZIA

SEDUTA CURVILINEA componibile, progettata per grandi spazi aperti, presenta una finitura esterna sabbata e interna liscia. È necessario predisporre una base di appoggio perfettamente livellata e idonea a sopportare il peso del manufatto.

CURVED MODULAR BENCH DESIGNED FOR LARGE, OPEN SPACES. IT FEATURES SAND-BLASTED FINISH ON THE BACK AND SMOOTH FINISH AT THE FRONT. TO BE INSTALLED ON PERFECTLY LEVEL SURFACE ABLE TO HOLD ITS WEIGHT.

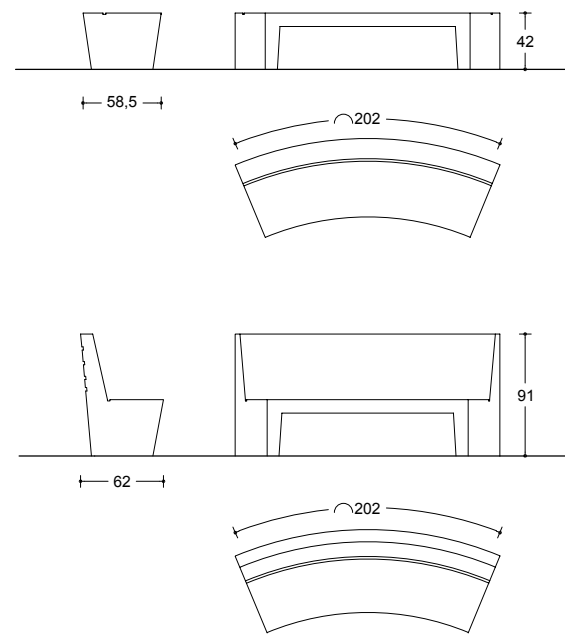

- CM 202x58,5x42H - KG 420 (SENZA SCHIENALE/WITHOUT BACKREST)
- CM 202x62x91H - KG 700 (CON SCHIENALE/WITH BACKREST)





EOS - SINGLE SEAT WITH BUILT-IN LED LIGHT
OSPEDALE BORGO ROMA - VERONA



EOS

DESIGN STUDIO MAR

EOS 1
• CM 50x50x60H - KG 150

- LAMPADA LED 3W - 230 V (IP 65) 400 LUMEN
- LED LAMP 3W - 230 V (IP 65) 400 LUMEN

SEDUTA SINGOLA IN PIETRA RICOSTRUITA DOTATA DI CORPO ILLUMINANTE.

SINGLE SEAT IN RECONSTRUCTED STONE WITH BUILT-IN LED LIGHT.



EOS 2
• CM 50x50x60H - KG 200



EOS 3
• CM 50x50x60H - KG 250

IL MANUFATTO VIENE PRODOTTO NELLE COLORAZIONI CEMENTO GRIGIO, CEMENTO BIANCO O PIETRA RICOSTRUITA. SU RICHIESTA VIENE EQUIPPAGGIATO CON ILLUMINAZIONE LED.

THE PRODUCT IS AVAILABLE IN NATURAL GREY CONCRETE, WHITE CONCRETE OR RECONSTRUCTED STONE. ON REQUEST IT CAN BE EQUIPPED WITH LED LIGHTING.



FOLIA BENCH
GIARDINI A MARE WATERFRONT - CESENATICO

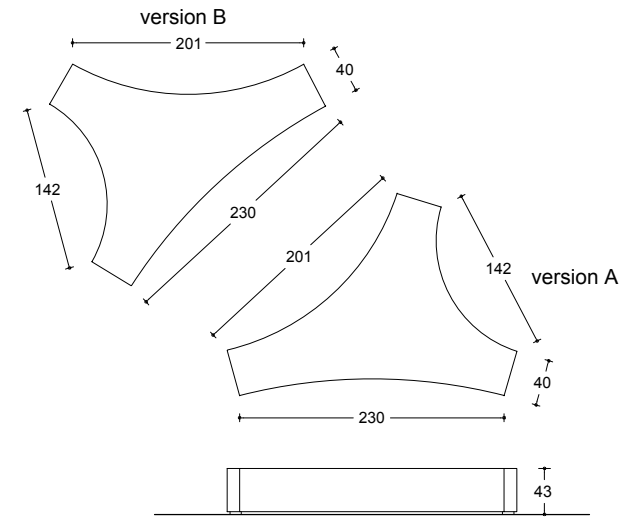

CM 201x230x43H - kG 1060

FOLIA

DESIGN MDU ARCHITETTI

PROPOSTA DI ARREDO URBANO CHE STIMOLA LA CREATIVITÀ DEL PROGETTISTA OFFRENDO INFINITE POSSIBILITÀ AGGREGATIVE, PARTENDO DA DUE MODULI BASE PERFETTAMENTE SPECULARI.

UNIQUE URBAN FURNITURE PIECE THAT OFFERS COUNTLESS COMBINATIONS AND THEREFORE INFINITE DESIGN SOLUTIONS. LOVED BY ARCHITECTS.



IL MANUFATTO VIENE PRODOTTO IN CEMENTO GRIGIO NATURALE, IN CEMENTO BIANCO OPPURE IN RIVESTIMENTO ACRILICO COLORATO COME DA CARTELLA COLORI.

THE PRODUCT IS MADE OF NATURAL GREY CONCRETE, WHITE CONCRETE OR COLOURED ACRYLIC COATING AS PER OUR COLOURS CHART.



FOLIA WOOD
AVAILABLE IN PINE OR EXOTIC WOOD - KG 1090

LITHOS CURVED

**MOD.2**

SEMICIRCONFERENZA COMPOSTA DA 9 PARTI
9 UNITS PRODUCE A SEMI-CIRCLE
(CM 170x40x45H - RAGGIO EST. / EXTERNAL RADIUS CM 550)

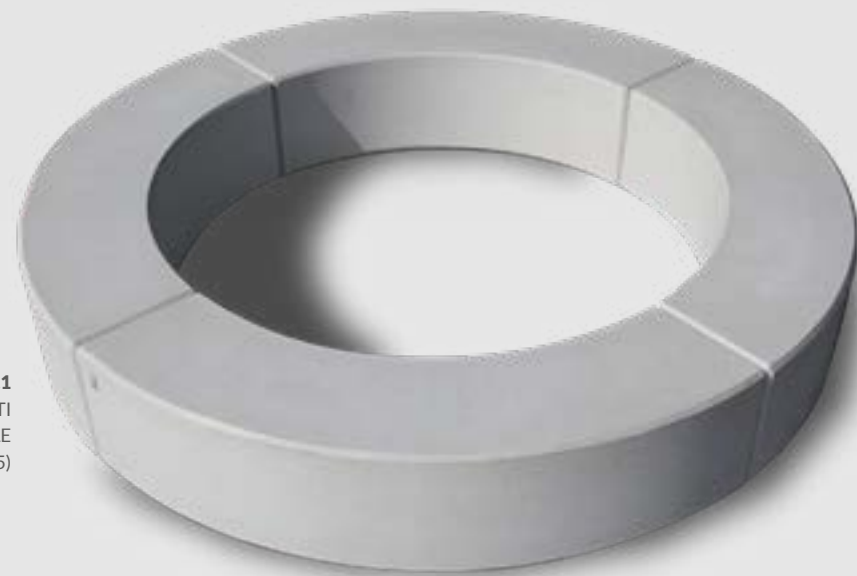
**MOD.1**

CIRCONFERENZA COMPLETA IN 4 PARTI
4 UNITS PRODUCE A CIRCLE
(CM 212x40x45H - RAGGIO EST. / EXTERNAL RADIUS CM 135)



GRUPPO PRESE DA INCASSO/BUILT-IN MULTI-PLUG SOCKET

LITHOS

DESIGN AVAA ASSOCIATI



SEDUTA MONOLITICA REALIZZATA IN PIETRA RICOSTRUITA, DISPONIBILE NEI COLORI STANDARD (CEMENTO GRIGIO E BIANCO), CON RIVESTIMENTO ACRILICO COLORATO O IN PIETRA RICOSTRUITA.

SINGLE-BLOCK CONCRETE BENCH AVAILABLE IN ALL STANDARD COLOURS AND FINISHES: GREY OR WHITE CONCRETE, COLOURED ACRYLIC COATING OR POLISHED RECONSTRUCTED STONE.

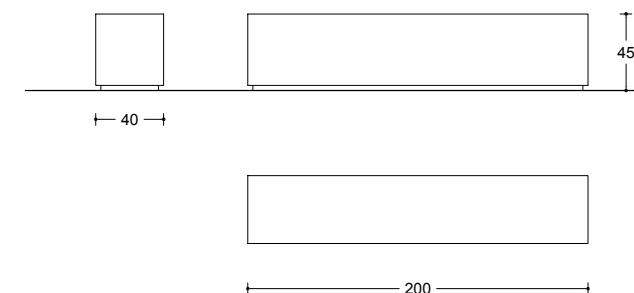

VERSIONE SENZA SCHIENALE IN LEGNO/WOOD NO BACKREST:

- CM.200x40x45H - KG.550
- CM.300x40x45H - KG.880
- CM.120x40x45H - KG.290



LITHOS BENCHES
GIARDINI BRUSCA - GENOVA



LITHOS WOOD

SEDUTA MONOLITICA REALIZZATA IN PIETRA RICOSTRUITA, DISPONIBILE NEI COLORI STANDARD (CEMENTO GRIGIO E BIANCO), CON RIVESTIMENTO ACRILICO COLORATO O IN PIETRA RICOSTRUITA.

SINGLE-BLOCK CONCRETE BENCH AVAILABLE IN ALL STANDARD COLOURS WITH WOODEN TOP WITH OR WITHOUT BACKREST.

LITHOS WOOD È LA VERSIONE DOTATA DI SEDUTA IN LEGNO, FORNITA IN 4 VARIANTI:

- LEGNO DI PINO NORDICO IMPREGNATO IN AUTOCLAVE
- LEGNO ESOTICO IMPREGNATO COLOR NOCE
- ECOLEGNO: PRODOTTO ECOCOMPATIBILE COMPOSTO DA POLIMERI E RESIDUI DELLA LAVORAZIONE DEL LEGNO
- LEGNO DI LARICE NATURALE

LITHOS WOOD IS THE VERSION WITH WOODEN SEAT, 4 OPTIONS AVAILABLE:

- SCANDINAVIAN VACUUM IMPREGNATED PINE WOOD
- WALNUT COLOURED IMPREGNATED EXOTIC WOOD
- ECO WOOD, COMPOSITE MATERIAL MADE OF WOOD FIBER/ WOOD POWDER AND POLYMERS
- WITH NATURAL LARCH WOOD

LITHOS WOOD CON ECOLEGNO
LITHOS WITH ECO WOOD SEAT

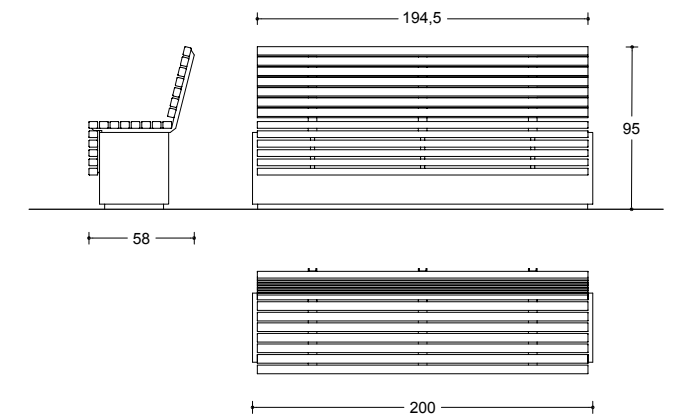

- VERSIONE SENZA SCHIENALE IN ECOLEGNO/ECO WOOD NO BACKREST: CM 200x42,5x49,5H - KG 575
- VERSIONE SENZA SCHIENALE IN LEGNO/WOOD NO BACKREST: CM 200x48,5x51.5H - KG 590
- VERSIONE CON SEDILE E SCHIENALE IN ECOLEGNO/ ECO WOOD SEAT AND BACKREST: CM 200x58x94H - KG 585
- VERSIONE CON SEDILE E SCHIENALE IN LEGNO/WOOD SEAT AND BACKREST: CM 200x58x95H - KG 600
- VERSIONE CON SEDILE E SCHIENALE SINGOLO IN LEGNO/WOOD SEAT AND SINGLE BACKREST: CM 120x50x95H - KG 300



VERSIONE CON ECOLEGNO
ECO WOOD VERSION

SEDUTA IN LEGNO ESOTICO CON SCHIENALE
ESOTIC WOOD SEAT WITH BACKREST

- CM 400x78x45H - KG 1580
- CM 400x78x95H - KG 1600
(CON SEDUTA IN LEGNO/WOODEN SEAT L=CM 285)



LITHOS CON SEDUTA IN LARICE NATURALE
WITH NATURAL LARCH WOOD SEAT

- CM.200x48,5x50H



MEGA LITHOS

È LA VERSIONE EXTRA LARGE DELLA PANCHINA LITHOS.
LA SEDUTA È IDONEA ANCHE COME BARRIERA
ANTITERRORISMO.

EXTRA LONG AND EXTRA LARGE VERSION OF THE LITHOS
BENCH. SUITABLE ALSO AS ANTI-TERRORISM BARRIER.



LITHOS BENCH CON 3 SCHIENALI E BRACCIOLI
IN ACCIAIO ZINCATO E VERNICIATO
LITHOS BENCH WITH 3 BACKRESTS AND ARMRESTS
IN GALVANIZED AND POWDER COATED STEEL



ROLLER

DESIGN ZPZ PARTNERS

• Ø CM 200x42H - KG 1200
Ø INTERNO CM 100

SEDUTA MONOLITICA IN PIETRA RICOSTRUITA, UTILIZZABILE ANCHE COME FIORIERA NELLA PARTE CENTRALE.

THIS SINGLE-BLOCK CIRCULAR SEATING HAS A DOUGHNUT SHAPE WITH AN EMPTY CENTRE (INNER Ø 100 CM) PROVIDING THE PERFECT PLACE FOR A PLANTER.

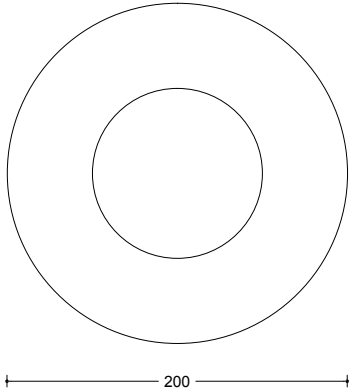
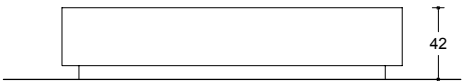

DISPONIBILE NELLE COLORAZIONI STANDARD: CEMENTO GRIGIO E BIANCO E RIVESTIMENTO ACRILICO COLORATO.

AVAILABLE IN STANDARD COLOURS: GREY AND WHITE CONCRETE AND COLOURED ACRYLIC PAINTS.

PIAZZA MARINA - PALERMO





VEGA

QUESTO MODELLO, COSTITUITO DA ROBUSTE FIANCATE IN ACCIAIO E DOGHE IN LEGNO, PUÒ ESSERE UTILIZZATO SIA COME PANCHINA SINGOLA A TRE POSTI SIA COME SEDUTA MODULARE PERMETTENDO QUINDI DI REALIZZARE ELEMENTI DI SEDUTA CONTINUI.

A MODULAR BENCH CONSISTING OF TWO ROBUST STEEL SIDES AND WOODEN SLATS. CAN BE BOTH A SINGLE THREE-SEATER OR ALIGNED IN SERIES TO CREATE CONTINUOUS SEATING OF THE DESIRED LENGTH.

VEGA IN ECOLEGNO

È UNA NUOVA VERSIONE - DOTATA DI TRE BASAMENTI IN ACCIAIO - CHE UTILIZZA UN MATERIALE ECOSOSTENIBILE: IL PRODOTTO INFATTI NASCE DALL'IMPIEGO DI RESIDUI DI LAVORAZIONE DEL LEGNO AGGREGATI CON POLIMERI RIGENERATI.

- L'ASPETTO FINALE È COMPARABILE A QUELLO DEL LEGNO NATURALE MA GARANTISCE UNA MAGGIORE RESISTENZA AGLI AGENTI ATMOSFERICI E NON RICHIEDE INTERVENTI DI MANUTENZIONE PERIODICA.

VEGA WITH ECO WOOD

A VERSION - WITH THREE STEEL SUPPORTS - MADE WITH ECO-WOOD SLATS, A SUSTAINABLE ALTERNATIVE TO WOOD, AN ECO-FRIENDLY COMPOSITE MATERIAL COMBINING WOOD FIBERS WITH REGENERATED POLYMERS.

- THE FINAL APPEARANCE IS VERY SIMILAR TO NATURAL WOOD, BUT ENSURES HIGHER RESISTANCE TO WEATHER CONDITIONS AND REQUIRES NO PERIODIC MAINTENANCE.

- CM 200x72x83H - KG 70

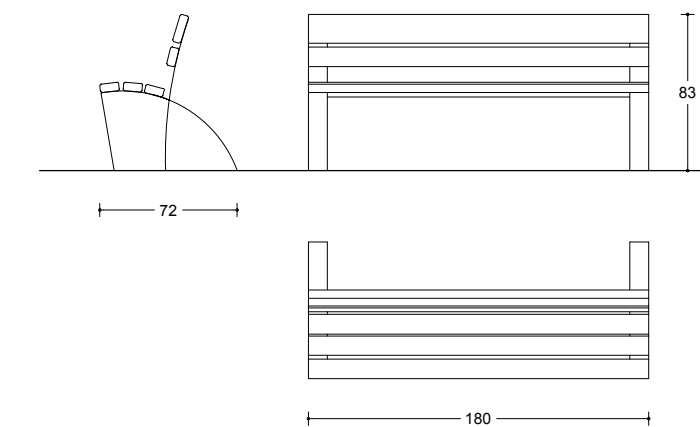

- CM 180x72x83H - KG 50 (1 MODULO/1 MODULE)
LEGNO PINO O LEGNO ESOTICO/PINE OR EXOTIC WOOD



HYDRA

SEDUTA MONOBLOCCO IN PIETRA RICOSTRUITA RESA CONFORTEVOLE CON L'INSERIMENTO DI UN PIANO IN LEGNO. È DISPONIBILE ANCHE LA VERSIONE CON SCHIENALE IN LEGNO O CON SEDUTE E COLORI DIVERSI.

THIS SINGLE PIECE BENCH IN RECONSTRUCTED STONE IS MADE MORE COMFORTABLE THANKS TO THE ADDITION OF A TIMBER SEAT. ALSO OFFERED WITH TIMBER BACKREST, AND WITH OTHER SEATING OPTIONS AND COLOURS.



- SENZA SCHIENALE/WITHOUT BACKREST
CM 200x60x47H - KG 520
- CON SCHIENALE/WITH BACKREST
CM 200x74x80H - KG.535
- SENZA SCHIENALE + SEDUTA IN LEGNO
WITHOUT BACKREST + WOODEN SEAT
CM 200x60x47H - KG.510

HYDRA BENCH
ZOGRAFOU - ATHENS (GR)

ASTER

SEDUTA CON SCHIENALE MONOBLOCCO REALIZZATA IN PIETRA RICOSTRUITA. UNA PANCHINA DAL DESIGN MODERNO, SOLIDA E DUREVOLE COME TUTTI GLI ARREDI CALZOLARI.

RECONSTRUCTED STONE SINGLE-PIECE SEAT WITH BACKREST. A MODERN BENCH DESIGNED TO BE EXTREMELY DURABLE AND HARDWEARING LIKE ALL CALZOLARI'S FURNISHINGS.



• CM 180x65x80H - KG 620

RONDÒ

L'ARMONIA DELLE LINEE E IL GRANDE EFFETTO SCENOGRAFICO D'INSIEME CARATTERIZZANO QUESTA SEDUTA CURVILINEA CHE RAPPRESENTA UN NUOVO APPROCCIO ALL'ARREDO DI GRANDI AREE PUBBLICHE.

THE SINUOUS LINES AND THE OVERALL VISUAL ATTRACTIVENESS ARE THE QUALITIES THAT DEFINE THIS CURVILINEAR BENCH, AN ITEM SUGGESTING A NEW APPROACH TOWARDS THE FURNISHING OF BIG PUBLIC AREAS.



• CM 182x65x83H - KG 560



GINESTRA

UN GRANDE CLASSICO CHE UNISCE IL COMFORT DELLA SEDUTA IN LEGNO ALLA SOLIDITÀ DELLE FIANCATE IN PIETRA RICOSTRUITA. È POSSIBILE PREDERE UN FORO PER IL FISSAGGIO A TERRA DELLE FIANCATE (OPTIONAL).

A GREAT CLASSIC THAT COMBINES THE COMFORT OF A WOODEN SEAT WITH THE ROBUSTNESS OF CONCRETE SIDES. ALSO AVAILABLE WITH HOLES FOR GROUND-FIXING (OPTIONAL).

- CON SCHIENALE/WITH BACKREST: CM 220x68x80H - KG 315
- SENZA SCHIENALE/WITHOUT BACKREST: CM 220x68x40H - KG 256
- LEGNO DI PINO IMPREGNATO O LEGNO ESOTICO/ IMPREGNATED PINE WOOD OR EXOTIC WOOD

DALIA

SEDUTA CHE S'ISPIRA ALLA TRADIZIONE STORICA "RILETTA" IN CHIAVE CONTEMPORANEA. E' DOTATA DI BRACCIOLI E DI UN PIANO DI SEDUTA PIÙ ALTO PER OFFRIRE UNA MAGGIORE FACILITÀ DI IMPIEGO.

BORN FROM TRADITIONAL DESIGN AND "REINTERPRETED" WITH A MODERN TWIST, DALIA FEATURES COMFORTABLE ARMRESTS AND A HIGHER SEAT LEVEL OFFERING A MORE PLEASANT SEATING EXPERIENCE.

DESIGN GIOVANNNA FRANCO REPELLINI



- CM 234x75x85H - KG 425
- LEGNO ESOTICO/ EXOTIC WOOD



PANCHINE CLASSICHE SEATS FOR PARKS

UNA SELEZIONE DI PANCHINE, ALCUNE CON DESIGN TRADIZIONALE ALTRE CONTEMPORANEE, CHE TROVANO UN IMPIEGO DIFFUSO NEI CONTESTI URBANI PIÙ ETEROGENEI.

A SELECTION OF TRADITIONAL AND CONTEMPORARY BENCHES FOR THE MOST DIVERSE URBAN SETTINGS.



HEDERA



ARALIA



ROBINIA



MAGNOLIA



GARDENIA

MAGNOLIA BENCH

- IN ALLUMINIO O IN GHISA E LEGNO DI PINO IMPREGNATO IN AUTOCLAVE O LEGNO ESOTICO, OGGI È TRA LE PANCHINE PIÙ VENDUTE.
 - BESTSELLER - ALUMINIUM OR CAST IRON FRAME SEAT WITH VACUUM-PRESSURE IMPREGNATED PINE WOOD OR EXOTIC WOOD SLATS.
- CM 200x62x70H - ALLUMINIO/ALUMINIUM KG 31 - GHISA/CAST IRON KG 57

HEDERA BENCH

- IN ALLUMINIO O IN GHISA E LEGNO DI PINO IMPREGNATO IN AUTOCLAVE O LEGNO ESOTICO, VIENE IMPIEGATA SIA IN CONTESTI STORICI CHE IN AREE VERDI.
 - ALUMINIUM OR CAST IRON FRAME SEAT WITH VACUUM-PRESSURE IMPREGNATED PINE WOOD OR EXOTIC WOOD SLATS. VERSATILE SOLUTION FOR CITY CENTRES OR GREEN AREAS.
- CM 185x65x82H - ALLUMINIO/ALUMINIUM: KG 38 - GHISA/CAST IRON KG 66

ROBINIA BENCH

- IN ALLUMINIO O IN GHISA E LEGNO DI PINO IMPREGNATO IN AUTOCLAVE O LEGNO ESOTICO, SEDUTA DI FORMA ERGONOMICA.
 - ALUMINIUM OR CAST IRON FRAME SEAT WITH VACUUM-PRESSURE IMPREGNATED PINE WOOD OR EXOTIC WOOD SLATS. ERGONOMIC DESIGN.
- CM 194,5x71x78H - ALLUMINIO/ALUMINIUM: KG 48 - GHISA/CAST IRON KG 66

ARALIA BENCH

- È COMPOSTA DA DUE BASAMENTI DALLA LINEA SOBRIA E MODERNA, IN ALLUMINIO O GHISA E LEGNO DI PINO IMPREGNATO IN AUTOCLAVE O LEGNO ESOTICO.
 - ALUMINIUM OR CAST IRON FRAME SEAT WITH VACUUM-PRESSURE IMPREGNATED PINE WOOD OR EXOTIC WOOD SLATS. MINIMALIST YET ELEGANT DESIGN.
- CM 180x55x78H - ALLUMINIO/ALUMINIUM: KG 33 - GHISA/CAST IRON KG 48

GARDENIA BENCH

- PANCHINA CON TELAIO IN ACCIAIO ZINCATO A CALDO E LEGNO DI PINO IMPREGNATO IN AUTOCLAVE, CHE UNISCE LA ROBUSTEZZA STRUTTURALE ALLA LEGGEREZZA VISIVA.
 - GALVANIZED STEEL FRAME SEAT WITH VACUUM-PRESSURE IMPREGNATED PINE WOOD. STURDY YET VISUALLY LIGHT SOLUTION.
- CM 180x55x85H - KG 30



LA PANCHINA ROSSA CONTRO LA VIOLENZA SULLE DONNE

LA PANCHINA ROSSA, COLORE DEL SANGUE, SIMBOLEGGIA IL POSTO OCCUPATO DA UNA DONNA CHE NON C'È PIÙ. LA PANCHINA ROSSA LA MANTIENE IN VITA, MENTRE SENSIBILIZZA SULLA VIOLENZA MASCHILE E SUL FEMMINICIDIO. MANTIENE VIVA LA PRESENZA DELLA VITTIMA IN UN GIARDINO PUBBLICO, IN UNA PIAZZA, DAVANTI AD UNA SCUOLA O AD UN OSPEDALE, AD UN TRIBUNALE O AD UN MUSEO, IN UN CENTRO COMMERCIALE. L'IMPORTANTE È CHE VENGA POSIZIONATA IN PROSSIMITÀ DI PERCORSI O AREE DI SOSTA.

THE RED BENCH TO HELP END VIOLENCE AGAINST WOMEN

THE BENCH, RED LIKE THE COLOUR OF BLOOD, SYMBOLIZES THE PLACE OCCUPIED BY A WOMEN, VICTIM OF FEMICIDE. THE RED BENCH KEEPS HER ALIVE, WHILE RAISING AWARENESS ON GENDER VIOLENCE.

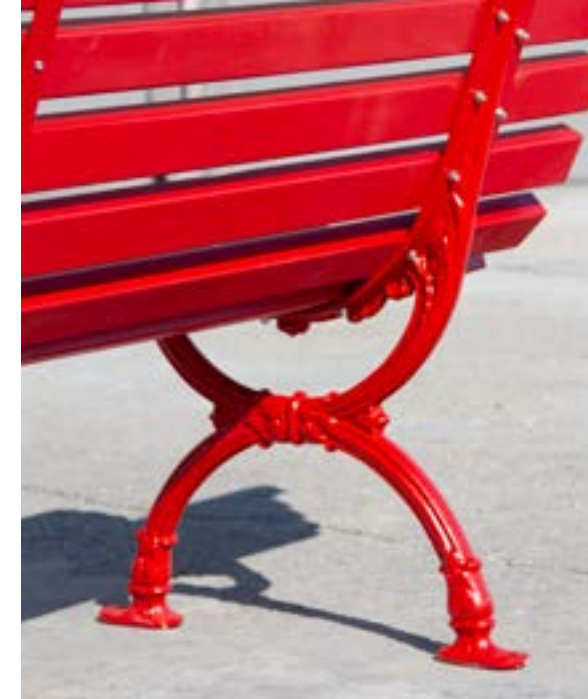

• CM 180x60x76H - KG 51



DAPHNE

PANCHINA ISPIRATA AI MODELLI DELLA TRADIZIONE STORICA ITALIANA, STUDIATA PER L'IMPIEGO NEI CENTRI STORICI.

BENCH INSPIRED BY TRADITIONAL ITALIAN STYLE AND DESIGNED FOR HISTORIC CENTRES.

È COSTITUITA DA:
DUE BASI IN GHISA DECORATA E VERNICIATA DI COLORE GRIGIO ANTRACITE MICACEO
UNDICI LISTONI IN LEGNO IROKO DI SEZ. MM 55X33 TRATTATI CON VERNICIATURA ALL'ACQUA NEI SEGUENTI COLORI:

- COLORE NOCE CHIARO CON IMPREGNANTE TRASPARENTE
- COLORE COPRENTE VERDE RAL 6005
- COLORE COPRENTE NERO RAL 9004
- COLORE COPRENTE ROSSO RAL 3001

IT CONSISTS OF:
TWO DECORATIVE CAST IRON BASES POWDER COATED TO MICACEOUS ANTHRACITE GREY
ELEVEN IROKO WOOD SLATS 55x33 MM SECTION TREATED WITH WATER-BASED PAINT TO THE FOLLOWING COLOURS:

- LIGHT WALNUT COLOUR WITH TRANSPARENT IMPREGNATING AGENT
- SOLID GREEN COLOUR RAL 6005
- SOLID BLACK COLOUR RAL 9004
- SOLID RED COLOUR RAL 3001

ANTARES



PANCHINA IN METALLO ZINCATO E VERNICIATO
(DA ASSEMBLARE)

GALVANIZED AND POWDER COATED STEEL
FRAME BENCH (TO BE ASSEMBLED)

CON SCHIENALE/WITH BACKREST

• CM 161x57x84H - KG 45

SENZA SCHIENALE/WITHOUT BACKREST

• CM 161x45x50H - KG 30

ANTARES WOOD

PANCHINA IN LEGNO CON SUPPORTI IN METALLO
ZINCATO E VERNICIATO (DA ASSEMBLARE)

GALVANIZED AND POWDER COATED STEEL FRAME
BENCH WITH TIMBER SLATS (TO BE ASSEMBLED)

CON SCHIENALE/WITH BACKREST

• CM 165x57x84H - KG 40

SENZA SCHIENALE/WITHOUT BACKREST

• CM 165x44,5x50H - KG 30



ARIES



ARIES WOOD

PANCHINA IN LEGNO CON SUPPORTI IN METALLO
ZINCATO E VERNICIATO (DA ASSEMBLARE)

TIMBER BENCH WITH GALVANIZED AND POWDER
COATED STEEL SUPPORTS (TO BE ASSEMBLED)

CON SCHIENALE/WITH BACKREST

• CM 200x60x88H - KG 45

SENZA SCHIENALE/WITHOUT BACKREST

• CM 200x50x48H - KG 35

ARIES STEEL

PANCHINA REALIZZATA IN METALLO ZINCATO E
VERNICIATO (DA ASSEMBLARE)

GALVANIZED AND POWDER COATED STEEL FRAME
BENCH (TO BE ASSEMBLED)

CON SCHIENALE/WITH BACKREST

• CM 200x61x86,5H - KG 60

SENZA SCHIENALE/WITHOUT BACKREST

• CM 200x55x45H - KG 42



ARGO

PANCHINA PER ANZIANI | SENIOR CITIZEN SEAT



PANCHINA IN LEGNO CON SUPPORTI IN METALLO ZINCATO E VERNICIATO (FORNITA MONTATA)

TIMBER BENCH WITH GALVANIZED AND POWDER COATED STEEL SUPPORTS (SUPPLIED ASSEMBLED)

- CM 180x60x82H - KG 35
- ALTEZZA DI SEDUTA MAGGIORATA/INCREASED SEAT HEIGHT
- LEGNO DI PINO O ESOTICO/PINE OR EXOTIC WOOD

ARGO - VERSIONE INCLUSIVA

ARGO BENCH - INCLUSIVE VERSION

- CM 262x60,4x81,7H - KG 95
- ALTEZZA DI SEDUTA MAGGIORATA/INCREASED SEAT HEIGHT



- CM.668x300x74H

LEVANTE

GRANDE SEDUTA COMBINABILE DOTATA DI SUPPORTI IN ACCIAIO ZINCATO E VERNICIATO A FORNO PIÙ SEDUTA E SCHIENALE IN LEGNO ESOTICO (OPPURE IN LEGNO DI PINO IMPREGNATO IN AUTOCLAVE). È DISPONIBILE ANCHE IN VERSIONE SENZA SCHIENALE. DISPONIBILI SU RICHIESTA PRESE ELETTRICHE PER RICARICA.

GREAT MODULAR SEATING MADE OF GALVANIZED AND POWDER COATED STEEL FRAME AND TIMBER SEAT AND BACKREST IN EXOTIC WOOD (OR PRESSURE-TREATED PINE WOOD). ALSO AVAILABLE IN A VERSION WITHOUT BACKREST. POWER SOCKETS ARE AVAILABLE UPON REQUEST.



110

AQUARIO | ARIETE

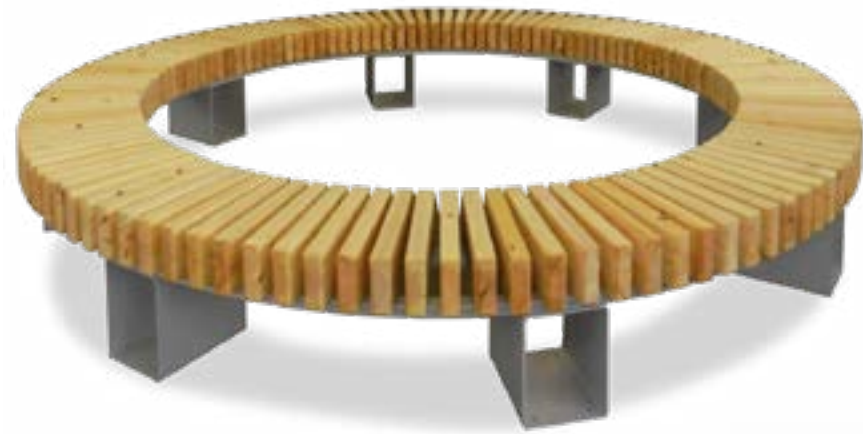

PANCHINE IN LEGNO CON STRUTTURA IN METALLO ZINCATO E VERNICIATO (DA ASSEMBLARE)

TIMBER BENCH WITH GALVANIZED AND POWDER COATED STEEL FRAME (TO BE ASSEMBLED)

- 1 SETTORE = 1/4 CIRCONFERENZA
- 1 SECTOR = 1/4 CIRCUMFERENCE
- LEGNO DI PINO O ESOTICO/PINE OR EXOTIC WOOD

AQUARIO

SENZA SCHIENALE/WITHOUT BACKREST

- CM Ø300x45H - KG 110
- PROF. SEDUTA/SEAT DEPTH CM 40



ARIETE

SENZA SCHIENALE/WITHOUT BACKREST

- CM Ø256x45H - KG 110
- PROF. SEDUTA/SEAT DEPTH CM 47



111

PANCHINE | BENCHES

CENTAURA



PANCHINA IN LEGNO CON STRUTTURA IN METALLO ZINCATO E VERNICIATO (DA ASSEMBLARE)

TIMBER BENCH WITH GALVANIZED AND POWDER COATED STEEL FRAME (TO BE ASSEMBLED)

CON SCHIENALE/WITH BACKREST

- CM 180x51,9x82H - KG 66

SENZA SCHIENALE/WITHOUT BACKREST

- CM 180x47x45,8H - KG 60
- LEGNO DI PINO O ESOTICO/PINE OR EXOTIC WOOD



CHAISE LONGUE

IN LEGNO CON STRUTTURA IN METALLO ZINCATO E VERNICIATO

TIMBER BENCH WITH GALVANIZED AND POWDER COATED STEEL FRAME

- CM 160x60x95,5H - KG 80
- LEGNO DI PINO/PINE WOOD

FIORIERE PLANTERS





FIORIERE ANDROMEDA IN PIETRA RICOSTRUITA ANDROMEDA CONCRETE PLANTERS

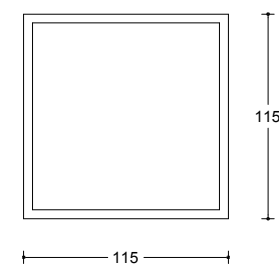
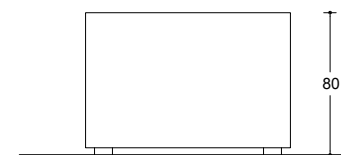
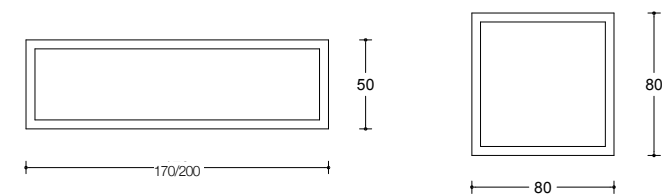
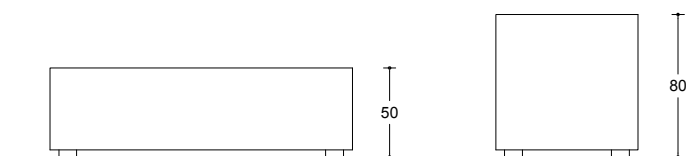

- CM 80x80x80H - CM 8^(*) - KG 400
- CM 115x115x80H - CM 7^(*) - KG 720
- CM 170x50x50H - CM 7^(*) - KG 420
- CM 200x50x50H - CM 7^(*) - KG 480

(*) SPESSORE/THICKNESS

A COMPLEMENTO DELLA FAMIGLIA OMONIMA, LA FIORIERA ANDROMEDA CON IL SUO LOOK MINIMALISTA È IN GRADO DI REGALARE UNA IMMAGINE CONTEMPORANEA AD OGNI PIAZZA O SPAZIO CORTILIVO, PUBBLICO O PRIVATO.

PART OF THE ANDROMEDA FAMILY, THESE PLANTERS CAN BE USED AS DECORATIVE ELEMENTS OF STREET FURNITURE, AS WELL AS ACCESS CONTROL. FEATURING MINIMALIST DESIGN AND SMOOTH SURFACE, THE PLANTERS SUIT ANY SPACE WHILST ALSO MATCHING THE SURROUNDING SEATING.

LE FIORIERE ANDROMEDA SONO DISPONIBILI IN CEMENTO GRIGIO NATURALE E BIANCO. DI GRANDE APPEAL ANCHE I COLORI ACRILICI NELLE TONALITÀ A CATALOGO.

ANDROMEDA PLANTERS ARE AVAILABLE IN FAIR FACED NATURAL GREY CONCRETE, WHITE CONCRETE, OR PAINTED WITH ACRYLIC COLOURS.



INTRECCI

DESIGN GIOVANNA FRANCO REPELLINI

QUESTA GAMMA DI FIORIERE NASCE DALLA VOLONTÀ DI CONIUGARE LE PREGIATE QUALITÀ DELL'ALLUMINIO CON UNA LAVORAZIONE "AD INTRECCIO" CHE ATTINGE ALLE TRADIZIONI STORICHE DELL'ARTIGIANATO ITALIANO. SONO IL COMPLEMENTO IDEALE DI CENTRI STORICI E DELLE AREE DI ALTO PREGIO ARCHITETTONICO O STORICO-ARTISTICO.

THIS PLANTERS COLLECTION WAS BORN OUT OF THE DESIRE TO COMBINE THE BEST QUALITIES OF ALUMINIUM WITH A WOVEN PATTERN INSPIRED BY THE UNIQUENESS OF TRADITIONAL ITALIAN CRAFTSMANSHIP. INTRECCI PLANTERS ARE A PERFECT COMPLEMENT TO ANY GREAT ARCHITECTURAL, HISTORIC AND HERITAGE SITE.



- CM 48x48x51H - KG 50
- CM 48x85x51H - KG 80
- CM Ø90 (Ø70 BASE) x 90H - KG 460

FIORIERE IN CEMENTO CONCRETE PLANTERS

FIORIERE QUADRATE, RETTANGOLARI E CIRCOLARI

MANUFATTI DAI MOLTEPLICI IMPIEGHI - SIA ALL'ESTERNO CHE ALL'INTERNO - ASSOLVONO SIA LA FUNZIONE DECORATIVA CHE QUELLA DI SICUREZZA COME UN EFFICACE DISSUASORE DEL TRAFFICO VEICOLARE. PER LE LORO CARATTERISTICHE TECNICHE E COSTRUTTIVE QUESTI MANUFATTI SONO IN GRADO DI SOPPORTARE QUALSIASI URTO ACCIDENTALE O DANNO DOVUTO AL VANDALISMO.

SQUARE, RECTANGULAR AND CIRCULAR PLANTERS

THESE PLANTERS WILL WORK WELL BOTH AS DECORATIVE STREET ELEMENTS AS WELL AS TRAFFIC AND PEDESTRIAN BARRIERS.

THANKS TO THE STURDINESS OF THEIR CONSTRUCTION, THEY ARE ABLE TO WITHSTAND ANY ACCIDENTAL COLLISION OR DAMAGE CAUSED BY ACTS OF VANDALISM.

- CM 72x72x50H - SPESSORE/THICKNESS CM 6 - KG. 280
- CM 72x72x65H - SPESSORE/THICKNESS CM 6 - KG. 310
- CM 90x90x50H - SPESSORE/THICKNESS CM 7 - KG. 460
- CM 90x90x70H - SPESSORE/THICKNESS CM 7 - KG. 520
- CM 90x90x85H - SPESSORE/THICKNESS CM 7 - KG. 600

- CM 100x50x50H - SPESSORE/THICKNESS CM 6 - KG. 260
- CM 140x50x50H - SPESSORE/THICKNESS CM 7 - KG. 385
- CM 140x50x70H - SPESSORE/THICKNESS CM 7 - KG. 500
- CM 120x140x40H - SPESSORE/THICKNESS CM 11 - KG. 776
- CM 120x140x50H - SPESSORE/THICKNESS CM 11 - KG. 886
- CM 120x140x70H - SPESSORE/THICKNESS CM 11 - KG. 1180

- CM Ø70x40H - SPESSORE/THICKNESS CM 5 - KG. 142
- CM Ø70x55H - SPESSORE/THICKNESS CM 5 - KG. 225
- CM Ø90x40H - SPESSORE/THICKNESS CM 6 - KG. 239
- CM Ø90x53H - SPESSORE/THICKNESS CM 6 - KG. 280
- CM Ø90x65H - SPESSORE/THICKNESS CM 6 - KG. 340
- CM Ø113x40H - SPESSORE/THICKNESS CM 6,5 - KG. 380
- CM Ø113x50H - SPESSORE/THICKNESS CM 6,5 - KG. 430
- CM Ø142x40H - SPESSORE/THICKNESS CM 9 - KG. 640
- CM Ø142x50H - SPESSORE/THICKNESS CM 9 - KG. 720
- CM Ø142x60H - SPESSORE/THICKNESS CM 9 - KG. 780

SEDILI IN LEGNO/WOOD SEATS

- A MENSOLA O A PONTE / CANTILEVERED OR BRIDGED CM 90x42x6
 - A MENSOLA O A PONTE / CANTILEVERED OR BRIDGED CM 120x42x6
 - A MENSOLA O A PONTE / CANTILEVERED OR BRIDGED CM 140x42x6
 - AD ANGOLO / CORNER CM 132x132x6
 - AD ANGOLO / CORNER CM 182x162x6
 - PERIMETRALE / PERIMETER CM 174x174x6
 - PERIMETRALE / PERIMETER CM 224x204x6
 - ESAGONALE / HEXAGONAL Ø CM 258
- (LEGNO DI PINO IMPREGNATO O LEGNO ESOTICO)
(IMPREGNATED PINE WOOD OR EXOTIC WOOD)



FIORIERE IN ACCIAIO STEEL PLANTERS



FIORIERE IN ACCIAIO SU MISURA CON SEDUTA IN LEGNO
CUSTOMIZED STEEL PLANTERS WITH WOODEN SEAT
 INGOMBRO MASSIMO INCLUSO SEDUTE IN LEGNO ESOTICO
 MAXIMUM SIZE INCLUDING EXOTIC WOOD SEATS

- CIRCOLARE / CIRCULAR: CM Ø200x75H
- RETTANGOLARE / RECTANGULAR: CM 200x100x75H

FORIERE IN ACCIAIO ZINCATO E VERNICIATO
PLANTERS IN GALVANIZED AND POWDER COATED STEEL

CIRCOLARE / CIRCULAR

- CM Ø50x50H
- CM Ø70x70H
- CM Ø80x100H
- CM Ø100x100H

QUADRATA / SQUARE

- CM 50x50x50H
- CM 70x70x70H
- CM 80x80x100H
- CM 100x100x100H

TRONCO CONICA / CONICAL

- CM Ø50x50H (INGOMBRO MASSIMO/ MAXIMUM SIZE)
- CM Ø70x70H (INGOMBRO MASSIMO/ MAXIMUM SIZE)
- CM Ø80x100H (INGOMBRO MASSIMO/ MAXIMUM SIZE)
- CM Ø100x100H (INGOMBRO MASSIMO/ MAXIMUM SIZE)



COMPLEMENTI
OTHER FURNISHINGS





DEVIATORI IN PIETRA RICOSTRUITA CONCRETE BOLLARDS

LA VASTA GAMMA DI MODELLI PERMETTE DI RISOLVERE LE PROBLEMATICHE PIÙ FREQUENTI NELLA GESTIONE DEL TRAFFICO VEICOLARE.

SU ALCUNI MODELLI SONO DISPONIBILI SU RICHIESTA: CATADIOTTRI, DUE TIPI DI CATENA E I RELATIVI GOLFARI.

A WIDE RANGE OF BOLLARDS OFFERS DIFFERENT SOLUTIONS FOR ALL KIND OF ISSUES RELATED TO VEHICLE TRAFFIC CONTROL AND MANAGEMENT.

AVAILABLE ACCESSORIES UPON REQUEST: REFLECTORS, TWO TYPES OF CHAIN AND COMPLEMENTING EYEBOLTS.



CATADIOTTRI/REFLECTORS



CATENA PESANTE/HEAVY CHAIN

CATENA E RELATIVI GOLFARI
CHAIN AND EYEBOLTS**MOD. I**

- CM Ø35x80H - KG 173
- CM Ø35x110H - KG 254

MOD. B

- CM Ø32/36x65H - KG 150
- CM Ø36/40x110 - KG 290

MOD. F

- CM Ø50x73H - KG 180
- CM Ø32 (COLONNA/COLUMN)

MOD. A

- CM 45x45x65H - KG 90
- CM 45x45x51H - KG 75

**MOD. C**

- CM Ø50x52H - KG 220

**MOD. O**

- CM Ø45x52H - KG 191

**MOD. E**

- CM 40x40x56H - KG 200
- CM 58x58x60H - KG 450

**MOD. G**

- CM Ø52 (BASE)x77H - KG 200

**MOD. H**

- CM Ø58 (BASE)x68H - KG 270

**MOD. D**

- CM 45x45x68H - KG 240



BOLLARDS AND PLANTERS
WATERFRONT - RAPALLO (GE)



MOD. V
• CM 50x50x50H - KG 290



MOD. Q BETON
• CM Ø30 - KG 35
• CM Ø40 - KG 60
• CON PERNO IN ACCIAIO PER FISSAGGIO A TERRA
WITH STEEL ROOT TO CAST INTO CONCRETE



MOD. U
• CM 40x40x45H - KG 170
DISPONIBILI ANCHE IN:/ALSO AVAILABLE WITH:
• RIVESTIMENTO ACRILICO/ACRYLIC COATING N.7-8-9-10

BARRIERE ANTITERRORISMO ANTI-TERRORISM BARRIERS

DESIGN ASTER
PRODOTTO BREVETTATO/PROTECTED BY EUROPEAN PATENT



È UN MONOBLOCCO REALIZZATO IN PIETRA RICOSTRUITA CON FINITURA SABBIAIA + RIVESTIMENTO ACRILICO IDROREPELENTE TRASPARENTE. IL MANUFATTO È DOTATO DI UN INCAVO PER INSERIMENTO DI UNA TARGA (OPTIONAL) CON LOGO DEL COMMITTENTE. CEMENTO MICROSABBIATO: GRIGIO PERLA, BIANCO MARMOREO, ROSA PASTELLO.

THE SIMPLE STRUCTURE IS MADE OF RECONSTRUCTED STONE + CLEAR WATER- REPELLENT FINISH. THE STRUCTURE CAN BE EQUIPPED WITH A HOLLOW FOR A PLATE WITH THE CUSTOMER'S LOGO.

MICRO SAND-BLASTED CONCRETE: PEARL GREY, MARBLE WHITE, BABY PINK

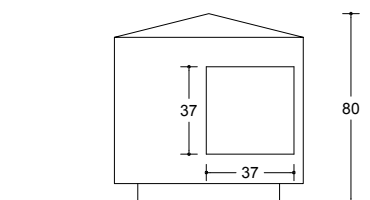

• CM 80x80x80H - 1120 KG

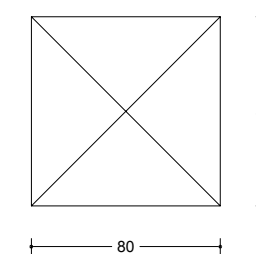

DEVIATORI IN METALLO METAL BOLLARDS



MOD. M - N - P - T - Q - S
 DISPONIBILI IN **GHISA** O **ALLUMINIO**, ADATTI PER LA COLLOCAZIONE IN CENTRI STORICI, SONO VERNICIATI A FORNO CON POLVERE POLIESTERE GRIGIO MICACEO SU FONDO ZINCATO. SUI MODELLI M E P È DISPONIBILE LA VERSIONE REMOVIBILE.

MADE OF **POWDER COATED CAST IRON** OR **ALUMINIUM** (ANTHRACITE GREY COLOUR WITH MICA EFFECT), THESE BOLLARDS ARE PERFECT TO BE INSTALLED IN HISTORIC CITY CENTRES. THE MODELS "M" AND "P" ARE ALSO AVAILABLE IN REMOVABLE VERSION.

- M** CM Ø10 (BASE Ø13)x140H (110H FUORI TERRA/ABOVE GROUND)
 • GHISA/CAST IRON: KG 29,5
 • ALLUMINIO/ALUMINIUM: KG 11,8
 DISPONIBILE ANCHE IN VERSIONE RIMOVIBILE/ALSO AVAILABLE IN A REMOVABLE VERSION
- N** CM Ø9,0x144H
 • GHISA/CAST IRON: KG 26,5
 • ALLUMINIO/ALUMINIUM: KG. 10,6
- P** CM Ø12 (BASE Ø30)x80H (69H FUORI TERRA/ABOVE GROUND)
 • GHISA/CAST IRON: KG 28,5
 • ALLUMINIO/ALUMINIUM: KG 11,4
 DISPONIBILE ANCHE IN VERSIONE RIMOVIBILE/ALSO AVAILABLE IN A REMOVABLE VERSION
- T** CM Ø20x80H
 • GHISA/CAST IRON: KG 24
 • ALLUMINIO/ALUMINIUM: KG 9,7
- Q** CM Ø30 (13H INNESTO DA INTERRARE/ROOT TO BE GROUT-IN)
 • GHISA/CAST IRON: KG 22
 • ALLUMINIO/ALUMINIUM: KG 11,4
- S** CM Ø25x35H
 • GHISA/CAST IRON: KG 16
 • ALLUMINIO/ALUMINIUM: KG 6,4

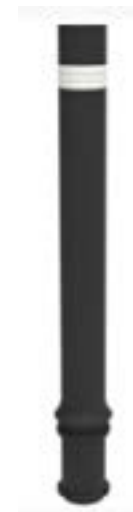

FLEX-G
 DEVIATORE DI TRAFFICO FLESSIBILE REALIZZATO IN POLIURETANO CON BANDA RIFRANGENTE.

FLEXIBLE BOLLARD MADE OF POLYURETHANE WITH REFLECTIVE BAND.

DISPONIBILE IN VERSIONE DA TASSELLARE A TERRA O DA INGHISARE.
 AVAILABLE IN FLANGED SURFACE FIXED OR ROOT FIXED VERSION.
 • Ø CM 10x86.5H FUORI TERRA/ABOVE GROUND (H 106 TOTALE/ TOTAL HEIGHT) - BASE CM 16x16 - PESO/WEIGHT KG 3



DEVIATORI IN METALLO METAL BOLLARDS



MOD. R1 - R2
 DISPONIBILE IN **ACCIAIO VERNICIATO A FORNO** CON POLVERE POLIESTERE GRIGIO MICACEO SU FONDO ZINCATO. VERSIONE REMOVIBILE SU MOD. R1.

MADE OF **STEEL, GALVANIZED AND POLYESTER POWDER COATED** TO ANTHRACITE GREY (MICA EFFECT). MOD. R1 AVAILABLE ALSO IN REMOVABLE VERSION.

- CM Ø7,5x120H - KG 5,5

MOD. L
 DISPONIBILE IN **ACCIAIO INOX AISI 304** AD ALTO CARICO D'URTO, È DOTATO DI **BASAMENTO RINFORZATO** IDONEO ALL'UTILIZZO IN ZONE CON INTENSO TRAFFICO VEICOLARE.

HEAVY-DUTY BOLLARD MADE IN AISI 304 **STAINLESS STEEL** WITH **REINFORCED BASE**. RECOMMENDED FOR HIGH-TRAFFIC AREAS.

- CM Ø8,5 (BASE Ø13,5) x 105H (90H FUORI TERRA/ABOVE GROUND) - KG 10



PARTICOLARE VERSIONE REMOVIBILE SU MOD. M
 REMOVABLE VERSION ON M TYPE DETAIL



DEVIATORI IN METALLO METAL BOLLARDS

**LEO 1**

CON FLANGIA A TERRA
WITH FLANGED BASE

**LEO 2**

CON 2 OCCHIELLI
WITH 2 CHAIN EYELETS

**LEO 3**

FISSO O RIMOVIBILE
FIXED OR REMOVABLE

CM Ø8x111,5H (FUORI TERRA/ABOVE GROUND)

**LEO 5**

CON 2 OCCHIELLI
WITH 2 CHAIN EYELETS

CM Ø6x108H
(FUORI TERRA/ABOVE GROUND)

**LEO 4**

FISSO O RIMOVIBILE CON CHIAVE
FIXED O REMOVABLE WITH KEY

- CM Ø10x122H (TOTALE / TOTAL HEIGHT)
102H (FUORI TERRA/ABOVE GROUND)



TRANSENNE SAFETY BARRIERS

**MOD. P**

- CM 100/150/200x100H (FUORI TERRA/ABOVE GROUND)

**MOD. L**

- CM 134x112H (FUORI TERRA/ABOVE GROUND)

MINI NEW JERSEY

MANUFATTO IDONEO ALLA DELIMITAZIONE DI
PERCORSI PEDONALI/CARRABILI E PISTE CICLABILI -
OPTIONAL: TRANSENNA REALIZZATA IN TUBOLARE
ZINCATO Ø 4,8 CM
BARRIERS FOR MARKING SIDEWALKS / CYCLE LANES /
PARKING AREAS. OPTIONAL EXTRA: HOOP BARRIER IN
GALVANIZED STEEL WITH A PIPE DIAMETER OF 4,8 CM

- CM 200x40x30H - KG 490

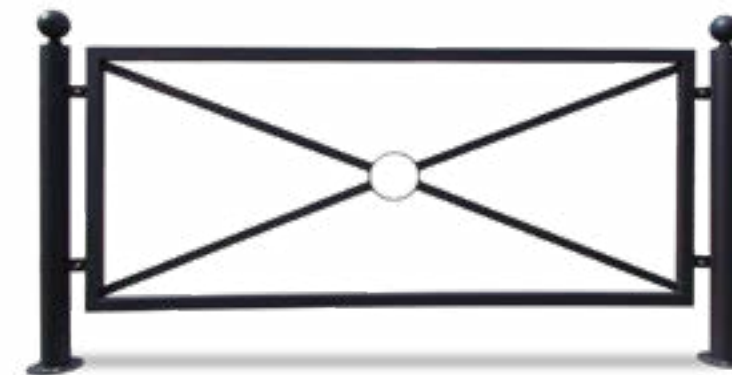
**MOD. B**

- CM 102,6/202,6x111,7H (FUORI TERRA/ABOVE GROUND)

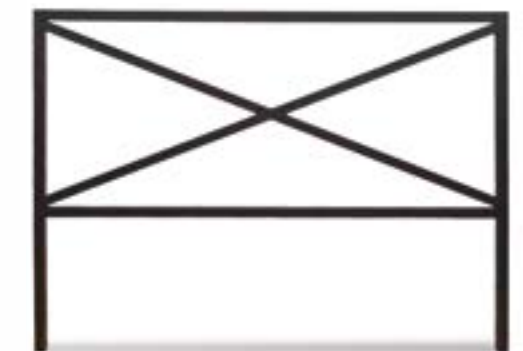
**MOD. V**

- CM 100/150/200x100H (FUORI TERRA/ABOVE GROUND)

CONTENITORI RIFIUTI IN PIETRA RICOSTRUITA CONCRETE LITTER BINS

PROGETTATI E COSTRUITI PER SODDISFARE VARI LIVELLI DI CAPIENZA, SI DISTINGUONO PER L'OTTIMA RESISTENZA AGLI URTI ACCIDENTALI ED ALLE AZIONI VANDALICHE, SENZA RICHIEDERE ALCUN FISSAGGIO A TERRA. L'INTERNO È ATTREZZABILE CON ANELLO PORTASACCO OPPURE CON CESTELLO IN LAMIERA ZINCATA O CON VASCHETTA POSACENERE.

A WIDE RANGE OF DURABLE AND LOW MAINTENANCE CONCRETE BINS OF VARIOUS CAPACITIES. FREE-STANDING AND HIGHLY RESISTANT TO ACCIDENTAL COLLISION OR DAMAGE CAUSED BY ACTS OF VANDALISM, THEY CAN BE FITTED WITH AN INNER RING, A GALVANIZED STEEL LINER AND AN ASHTRAY.

(FOTO A SINISTRA)
WATERFRONT - DRAPETSONA (GREECE)

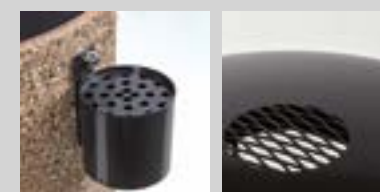

- POSACENERE UNIVERSALE
UNIVERSAL ASHTRAY
CM Ø12x12H
- POSACENERE SU MOD. H INTEGRATO
NELLA CUPOLINA
ASHTRAY INTEGRATED INTO THE LID IN MOD.H



- CESTELLO POSACENERE SU MOD.A / MOD.B
BASKET ASHTRAY ON MOD.A / MOD.B
- CESTELLO IN LAMIERA ZINCATA SU
GALVANIZED STEEL LINER ON
MOD.A / MOD.B / MOD.C / MOD.H



MALPENSA AIRPORT - MILANO



CESTELLO POSACENERE SU MOD.A
ASHTRAY ON MOD.A
• CM47x47x60H



POSACENERE SU MOD.H
ASHTRAY ON MOD.H

MOD. B

- CM 60x60x84H (105H CON CUPOLINA/WITH LID)
LT 190 - KG 320



MOD. A

- CM 47x47x60H (80H CON CUPOLINA/WITH LID)
LT 80 - KG 128



MOD. C

- CM Ø70x84H (105H CON CUPOLINA/WITH LID)
LT 210 - KG 250

139

CONTENITORI RIFIUTI IN PIETRA RICOSTRUITA
CONCRETE LITTER BINS



MOD. H

- CM Ø55x76H (103H CON CUPOLINA/WITH LID)
LT 125 - KG 180

COLORI DISPONIBILI/AVAILABLE COLOURS:
• GHIAIETTO LAVATO/WASHED FINE GRAVEL
• CEMENTO SABBIAIO/SAND BLASTED CONCRETE



- STRUTTURA IN METALLO: GRIGIO ANTRACITE
- PARETI IN: CEMENTO SABBBIATO - ACCIAIO VERNICIATO
- LE PARETI SONO PERSONALIZZABILI SU RICHIESTA DEL CLIENTE, DISPONIBILI ANCHE FIANCATE IN ALLUMINIO DIBOND® SERIGRAFATO E PERSONALIZZATO PER OGNI COMMITTENTE CON MESSAGGI PUBBLICITARI.
- IL POSACENERE "A ROTAZIONE" CONSENTE ALL'OPERATORE DI SVUOTARNE DIRETTAMENTE IL CONTENUTO NEL SACCO SOTTOSTANTE IN MODO SEMPLICE E IMMEDIATO.

- METAL FRAME: CHARCOAL GREY
- SIDES OPTIONS: SAND BLASTED CONCRETE SLABS - STEEL SHEETS
- SIDES CAN BE CUSTOMIZED UPON REQUEST, ALSO AVAILABLE CUSTOM PRINTED PANELS IN DIBOND® STEEL.
- THE PRACTICAL SPINNING ASHTRAY ALLOWS FOR AN EASY AND QUICK EMPTYING OF ITS CONTENT THAT FALLS NEATLY INTO THE UNDERLYING WASTE BAG.



- CM 52x52x110H - LT 86 - KG 190
- CON FIANCATE IN CALCESTRUZZO/WITH CONCRETE SIDES
- CON POSACENERE A ROTAZIONE AUTOPULENTE
- WITH SELF-CLEANING SPINNING ASHTRAY

SQUARE

DESIGN GIOVANNA FRANCO REPELLINI

È UN CESTONE GETTACARTA CHE OFFRE LA POSSIBILITÀ DI ALLESTIRE FIANCATE CON I MATERIALI PIÙ DIVERSI, IN VERSIONI STANDARD E CUSTOM.

WIDE RANGE OF STEEL SQUARE BINS WITH DIFFERENT SIDE OPTIONS, BOTH STANDARD AND CUSTOM.



GRUPPO PER RACCOLTA DIFFERENZIATA

PREVEDE LA CREAZIONE DI GRUPPI DI TRE O PIÙ CONTENITORI CON FIANCATE IN ALLUMINIO DIBOND SERIGRAFATO O PERSONALIZZATO PER OGNI COMMITTENTE.

RECYCLING BINS

GROUP OF THREE OR MORE BINS ALSO AVAILABLE WITH BESPOKE DIBOND ALUMINIUM SCREEN PRINTED PANELS, CUSTOMIZED TO THE CUSTOMER NEEDS.

**MOD. P - P1**

- CON E SENZA POSACENERE/WITH AND WITHOUT ASHTRAY
- ACCIAIO INOX AISI 304 - FINITURA SATINATA
- AISI 304 STAINLESS STEEL - SATIN FINISH
- CM 40x40x90H - KG 20

**MOD. HERCULES**

- CON POSACENERE/WITH ASHTRAY
- CM 45x29x100H - LT 90 - KG 40

**MOD. GIANO**

- CON POSACENERE/WITH ASHTRAY
- CM 58x58x115H - LT 180 - KG 100

CONTENITORI RIFIUTI IN METALLO STEEL LITTER BINS

**MOD. O**

- LEGNO DI PINO IMPREGNATO / VACUUM IMPREGNATED PINE WOOD
- CM Ø35x50H (150H PALO/POLE) - LT 27 - KG 20

MOD. ORFEO

- RIVESTITO IN PINO IMPREGNATO/VACUUM IMPREGNATED PINE WOOD
- CM Ø33x41H (120H PALO/POLE) - LT 26 - KG 12

**MOD. G**

- CON E SENZA COPERCHIO/WITH AND WITHOUT LID
- CM Ø30x53H (130H PALO/POLE) - LT 35 - KG 26

**MOD. M**

- CON COPERCHIO/WITH LID CM Ø26,5x44,5H (120H PALO/POLE) - LT 27 - KG 16
- SENZA COPERCHIO/WITHOUT LID CM Ø26,5x44,5H (130H PALO/POLE) - LT 27 - KG 20
- OPTIONAL: POSACENERE INSERITO NEL COPERCHIO/ASHTRAY INTEGRATED INTO THE LID

**MOD. ME**

- CON COPERCHIO SPEGNI SIGARETTA WITH LID AND CIGARETTE STUBBER
- CM Ø31x57H (120H PALO/POLE) - LT 50 - KG 25



DALL'ALTO VERSO IL BASSO/ FROM TOP TO BOTTOM

- POSACENERE SU/ASHTRAY ON MOD.G
- POSACENERE SU/ASHTRAY ON MOD.ME
- POSACENERE SU/ASHTRAY ON MOD.M

**MOD. MARTE**

- CM Ø27x49H (100H PALO/POLE) - LT 25 - KG 6

**MOD. PAN**

- CM Ø35x54,4H (100H PALO/POLE) - LT 45 - KG 12

CONTENITORI RIFIUTI IN ACCIAIO STEEL LITTER BINS



MOD. TESEO 1

- BASE IN METALLO/METAL BASE
- CM Ø49/57x90H - LT 80 - KG 30

MOD. TESEO 2

- BASE IN CEMENTO/CONCRETE BASE
- CM Ø50/57x95H - LT 80 - KG 70



MOD. TESEO 3

- CON COPERCHIO E POSACENERE, BASE IN METALLO
- WITH LID AND ASHTRAY AND METAL BASE
- CM Ø49/57x110H - LT 80 - KG 35

MOD. TESEO 4

- CON COPERCHIO E POSACENERE, BASE IN CEMENTO
- WITH LID AND ASHTRAY, CONCRETE BASE
- CM Ø50/57x114,5H - LT 80 - KG 75



MOD. ORIONE

- CON POSACENERE E ANELLO PORTA SACCO
- WITH ASHTRAY AND WASTE BAG RING
- CM 55X35x93H - LT 110 - KG 40

MOD. PERSEO

POSACENERE PREDISPOSTO PER FISSAGGIO A TERRA. REALIZZATO SIA IN ACCIAIO INOX CHE IN ACCIAIO VERNICIATO A FORNO. DISPONIBILE ANCHE IN VERSIONE DA FISSARE A MURO.
ASHTRAY TO BE GROUND FIXED. AVAILABLE IN STAINLESS STEEL OR IN THE POWDER-COATED STEEL VERSION. WALL MOUNTED VERSION ALSO AVAILABLE.

- TUBO/POLE: CM Ø11,5x130H
- FLANGIA DI BASE/BASE FLANGE: CM Ø32,0
- PESO/WEIGHT: KG 12

**MOD. ALCOR**

POSACENERE/ASHTRAY
• BASE/BASE: CM 24x24
• CM 15,3x13,5x100H

**MOD. APOLLO**

CAPIENTE POSACENERE PREDISPOSTO PER FISSAGGIO A TERRA. REALIZZATO IN ACCIAIO VERNICIATO A FORNO E DOTATO DI CONTENITORE INTERNO ESTRAIBILE. DISPONIBILE ANCHE IN VERSIONE DA FISSARE A MURO.

CAPACIOUS POWDER COATED STEEL ASHTRAY TO BE GROUND FIXED, EQUIPPED WITH REMOVABLE INTERNAL LINER. WALL MOUNTED VERSION ALSO AVAILABLE.

- CM 15x15x120H - KG 14

**MOD. PEGASO**

- CM Ø40x89H - LT 80 - KG 40
- BASE IN METALLO/METAL BASE CM Ø49
- BASE IN CEMENTO/CONCRETE BASE CM Ø50

**MOD. EOLO**

- VERNICIATA A FORNO, CON POSACENERE E CON CONTENITORE ESTRAIBILE
- POWDER COATED, WITH ASHTRAY AND WITH REMOVABLE LINER
- CM Ø40x80H - LT 80 - KG 30



DISPONIBILE ANCHE A PIANTA QUADRATA
WITH SQUARE PLAN ALSO AVAILABLE
• CM 40x40 (FOTO/PICTURE PAG.146)

**MOD. MIZAR**

- CON POSACENERE E BASE IN CEMENTO
- WITH ASHTRAY AND CONCRETE BASE
- CM Ø58/50x115H - LT 130 - KG 98,5

**MOD. RIGEL**

- CON POSACENERE E BASE IN CEMENTO
- WITH ASHTRAY AND CONCRETE BASE
- CM Ø55x110,9H - LT 130 - KG 66

**MOD. AREA**

- IN ACCIAIO INOX O VERNICIATO A FORNO
- IN STAINLESS STEEL OR IN POWDER COATED STEEL
- CM 60x27x108H (FUORI TERRA/ABOVE GROUND)
LT 60 - KG 37



CESTINO TRIPARTITO
CON ANELLI PORTASACCO INTERNI,
DISPONIBILE ANCHE CON COPERCHIO E POSACENERE INCORPORATO.
THREE-COMPARTMENT RECYCLING LITTER BIN
WITH SEPARATE BAG HOLDER RINGS,
AVAILABLE ALSO WITH LID AND INCORPORATED ASHTRAY.

- CM Ø45x74H - KG 30 - LT 120
- CM Ø45x108H - KG 45 - LT 120 (VERSIONE CON COPERCHIO+POSACENERE / VERSION WITH LID+ASHTRAY)

CESTINO QUADRIPARTITO
CON ANELLI PORTASACCO INTERNI.
FOUR-COMPARTMENT RECYCLING LITTER BIN
WITH SEPARATE BAG HOLDER RINGS.

- CM Ø54x74H - KG 35 - LT 160



TRIO - PORTASACCHI/BAG HOLDERS

- CM Ø35 (OGNI ANELLO/EACH HOLDER)
- CM Ø6x120H (PALO/POLE)

TRIO - CESTINI/CONTAINERS
CON COPERCHIO E POSACENERE
WITH LID AND ASHTRAY

- CM Ø35x55H (OGNI CESTINO/EACH CONTAINER)
- 42x3 CAPACITÀ LITRI /LITRES CAPACITY)



MOD. COROLLA
CON BASE IN CEMENTO/WITH CONCRETE BASE

- CM 75x81,6x109,5H - KG 100 (3 CONTENITORI/CONTAINERS)



MOD. MULTISECTOR

- CM 99x38,5x80H - KG 70
- DISPONIBILE ANCHE A 2-3-4 APERTURE
- AVAILABLE ALSO WITH 2-3-4 APERTURES

CESTINI PER RACCOLTA DIFFERENZIATA RECYCLING LITTER BINS



MOD. POLARIS

- CM 103x38,5x88,3H - KG 65
- DISPONIBILE ANCHE A 2-3-4 SETTORI/AVAILABLE ALSO WITH 2-3-4 APERTURES
- OPTIONAL: COPERCHIO CON SPEGNISGARETTA/LID WITH ASHTRAY





BIKE RACKS (MOD. D-INOX)
SUPERMERCATO ESSELUNGA - VERONA

BICISOSTA BIKE RACKS

PROGETTATI PER LA CREAZIONE DI CICLOPARCHEGGI PUBBLICI, PRIVATI O CONDOMINIALI.

DESIGNED FOR PUBLIC, PRIVATE OR COMMUNAL AREAS.

SOLUZIONI DISPONIBILI

- MODELLI CON RASTRELLIERA IN METALLO - ANCHE IN ACCIAIO INOX SU MOD. "D" - E FIANCATE IN CONGLOMERATO CEMENTIZIO OPPURE CON FIANCATE IN ACCIAIO, SU MOD. "C" E "G"
- MODELLI A UNO O DUE POSTI COMPLETAMENTE IN ACCIAIO, STUDIATI PER CONSENTIRE IL BLOCCAGGIO DEL TELAIO.

AVAILABLE OPTIONS

- METAL RACKS - ALSO AVAILABLE IN STAINLESS STEEL ("D" MODEL) - WITH CONCRETE OR STEEL BASES ("C" AND "G" MODELS)
- STEEL VERSIONS FOR 1 OR 2 BIKES CREATED TO ALLOW EASY WHEEL AND/OR FRAME LOCKING.



MOD. G
BIFRONTALE, BASI METALLO/DOUBLE-SIDED RACK,
METAL ENDS
• CM 125x75x45H - KG 45
• CM 175x75x45 H - KG 60

MOD. G
BIFRONTALE, BASI CEMENTO/DOUBLE-SIDED RACK,
CONCRETE ENDS
• CM 145x75x45H - KG 220
• CM 195x75x45 H - KG 230

MOD. F
TUBO/HOOP CYCLE STAND (DUE POSTI/TWO SLOTS)
• CM 100x95H (110H) Ø4,8 - KG 10
DISPONIBILE IN ACCIAIO INOX O VERNICIATO/AVAILABLE IN
POWDER COATED STEEL OR STAINLESS STEEL

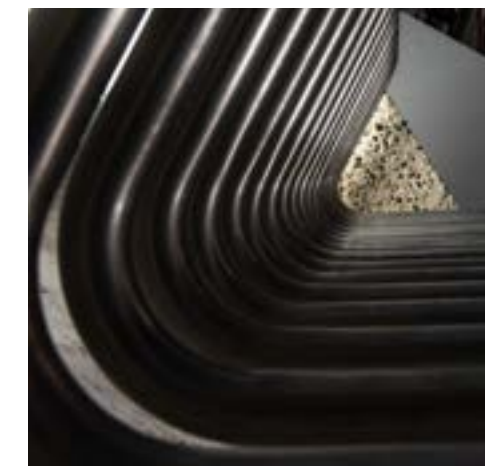

BICISOSTA
BIKE RACKS

MOD. C
BIFRONTALE, BASI METALLO/DOUBLE-SIDED RACK, METAL ENDS
• CM 225x75x46H - KG 60
• CM 315x75x46 H - KG 72



MOD. H
A UN POSTO/ONE SLOT CYCLE STAND
• CM 166x33x75H - KG 15



MOD. C
BIFRONTALE, BASI CEMENTO/ DOUBLE-SIDED RACK, CONCRETE ENDS
• CM 275x75x46H - KG 335
• CM 365x75x46 H - KG- 362



MOD. D
MONOFRONTALE, RASTRELLIERA IN METALLO VERNICIATO O IN ACCIAIO INOX
SINGLE-SIDED ONLY, POWDER COATED STEEL OR STAINLESS STEEL RACK
• CM 200x62x40H - KG 139

**MOD. SIRIO BETON**

- PORTABICICLETTE A 5/7/9 POSTI
- 5/7/9 SLOT CYCLE RACK
- CM 234/277/320x75x42H - KG 200/210/220

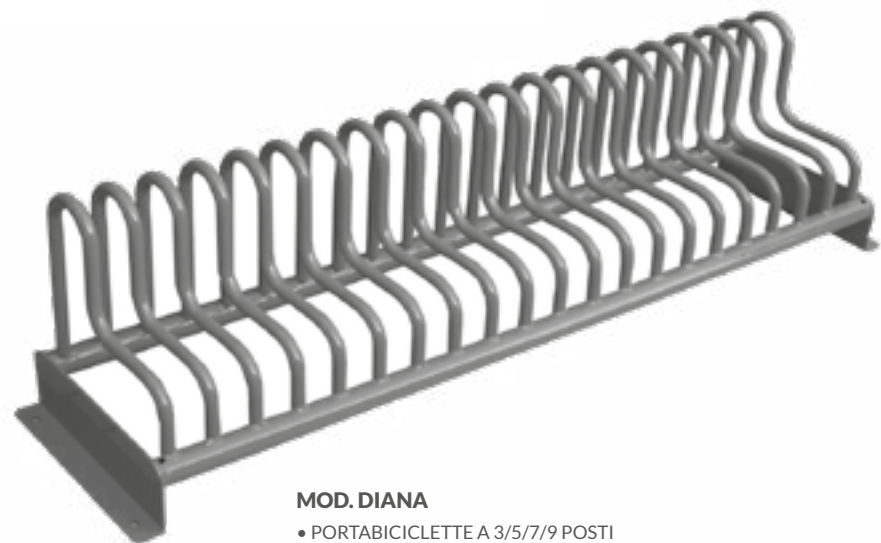
**MOD. DIANA**

- PORTABICICLETTE A 3/5/7/9 POSTI
- 3/5/7/9 SLOT CYCLE RACK
- CM 160/210/260/310x39x43H - KG 27/33/38/43

**MOD. SAGITTARIO**

- PORTABICICLETTE A 4/6 POSTI
- 4/6 SLOT CYCLE RACK
- CM 263/399x73x82H - KG 200/240

**MOD. CASTORE**

- VERNICIATO MONOFRONTALE (ANCHE IN VERSIONE BIFRONTALE)
- SINGLE-SIDED POWDER COATED CYCLE RACK (ALSO AVAILABLE IN DOUBLE SIDED VERSION)
- CM 200x50x60H - KG 30

**MOD. SATURNO**

- 4/6 POSTI CON STRUTTURA PREDISPOSTA PER FISSAGGIO TELAIO BICI
 - 4/6 SLOT CYCLE RACK WITH BIKE FRAME HOLDER
 - CM 211/311x122x70H - KG 60/80
- DISPONIBILE CON SUPPORTI INCLINATI A 45°
AVAILABLE WITH 45° ORIENTED SUPPORTS

- MOD. A**
- SINGOLO - MONOFRONTALE
 - ONE SLOT CONCRETE STAND - SINGLE-SIDED ONLY
 - CM 60x25x20H - KG 44

**MOD. B**

- 4 POSTI - MONOFRONTALE.
- 4 SLOT CONCRETE STAND - SINGLE-SIDED ONLY
- CM 60x170x20H - KG 320

**MOD. SIRIO**

- PORTABICICLETTE A 5/7/9 POSTI
- 5/7/9 SLOT CYCLE RACK
- CM 209,5/252,5/296,5x50x50,5H - KG 40/45/50

**MOD. ARTEMIDE**

- PORTABICICLETTA SINGOLO
- ONE SLOT CYCLE STAND
- CM 10x8,6x96H



162

BICISOSTA
BIKE RACKS

MOD. SESTANTE

- PORTABICICLETTE A 2 POSTI
- TWO SLOT CYCLE STAND
- CM 126,6x100x90H - KG 25

MOD. ALTAIR

- PORTABICICLETTE SINGOLO
- ONE SLOT CYCLE STAND
- CM 70x90x82H - KG 10



MOD. COMPASSO

- PORTABICICLETTE SINGOLO
- ONE SLOT CYCLE STAND
- CM Ø90x74H - KG 6



MOD. GAMMA

- PORTABICICLETTE SINGOLO
- ONE SLOT CYCLE STAND
- CM Ø76x102H - KG 8



MOD. NAOS

- PORTABICICLETTE SINGOLO
- ONE SLOT CYCLE STAND
- CM 50/70x101H - KG 5/7



MOD. LINCE

- PORTAMONOPATTINI 3 POSTI
- 3 SLOT SCOOTER STAND
- CM 135x120H - KG 20



163

BIKE STATION

PORTABICICLETTE A DUE PIANI

SI TRATTA DI UNA SOLUZIONE BREVETTATA PER OTTIMIZZARE GLI SPAZI DEDICATI ALLA SOSTA DI BICICLETTE SIA IN AMBIENTI INTERNI CHE ESTERNI, UTILIZZANDO COPERTURE PREFABBRICATE QUALI PENSILINE OPPURE BIKE PARKING. LE STRUTTURE SONO REALIZZATE IN ACCIAIO ZINCATO A NORME UNI, AUTOPORTANTI E DA FISSARE A TERRA SU PAVIMENTAZIONE IN CEMENTO DI IDONEA PORTATA.

TWO-TIER BIKE RACK

A PATENTED SOLUTION DESIGNED TO OPTIMIZE THE CYCLE PARKING SPACE BOTH INDOORS AND OUTDOORS. THE SELF-BEARING STRUCTURE IN GALVANIZED STEEL MADE IN ACCORDANCE WITH UNI STANDARDS IS TO BE FIXED ON A REINFORCED CONCRETE PLATFORM OF SUITABLE CAPACITY.

- DISPONIBILI CON ACCESSO MONO O BIFRONTALE
- AVAILABLE SINGLE- OR DOUBLE-SIDED



VELOPARK

- STRUTTURA PREFABBRICATA IN ACCIAIO CON ANTE SCORREVOLI
- PREFABRICATED STEEL STRUCTURE WITH SLIDING DOORS
- CM 200/300/400x200x220H - KG530/640/750



E-BIKE IMPIANTI PER RICARICA E MANUTENZIONE CHARGING AND MAINTENANCE STATIONS



MOD. A

- COLONNA CON ATTREZZI PER MANUTENZIONE E POMPA DI GONFIAGGIO
- E-BIKE MAINTENANCE STATION: MAINTENANCE TOOLS AND PUMP
- CM 59x44x160H - KG 20



MOD. B

- COLONNA CON POMPA E 2 PRESE SCHUKO + 2 STALLI BICI
- E-BIKE MAINTENANCE STATION: PUMP, 2 SCHUKO SOCKETS + 2 BIKE STANDS
- CM 57x27x75H - KG 10,8



MOD. C

- COLONNA CON POMPA + 4 PRESE SCHUKO
- E-BIKE MAINTENANCE STATION: PUMP + 4 SCHUKO SOCKETS
- CM 57x27x75H - KG 9

RASTRELLIERA IN ALLUMINIO PER RICARICA N.6 E-BIKES E MONOPATTINI

DISPONIBILE ANCHE IN VERSIONE BIFRONTALE (N.12 PRESE) E ATTREZZABILE CON COLONNINA DI MANUTENZIONE BICI SU UNA TESTATA

- CM.270x50x100,5H - KG.45

ALUMINIUM CHARGING RACK FOR 6 E-BIKES AND SCOOTERS

AVAILABLE ALSO IN DOUBLE-SIDED VERSION (12 SOCKETS) AND WITH MAINTENANCE STAND INSTALLED AT ONE END.

- CM.270x50x100,5H - KG.45

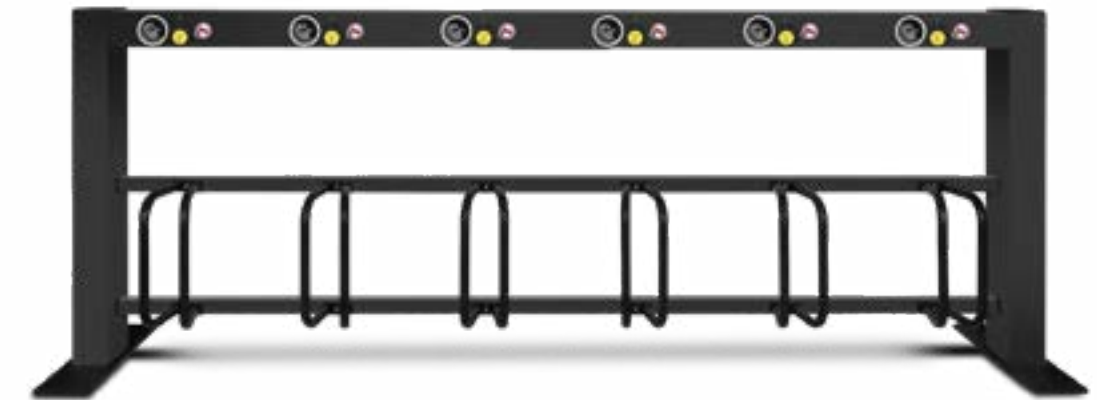

SMART SHELTER

PENSILINA IN ACCIAIO PER RICARICA E-BIKES E MONOPATTINI INDIPENDENTE DALLA RETE ELETTRICA. DOTATA DI RASTRELLIERA CON N.5 PRESE SHUCO 220V + MODULO FV 400W + BATTERIE 160 AH

OFF-GRID STEEL SHELTER FOR E-BIKE AND SCOOTER CHARGING. EQUIPPED WITH 5 220V SCHUKO SOCKETS + 400W PV MODULE + 160 AH BATTERIES





MOD. ARIANNA
PENSILINA ATTESA BUS/BUS STOP SHELTER

- COPERTURA E PARETE DI FONDO IN POLICARBONATO ALVEOLARE
- ROOF AND REAR PANELS IN ALVEOLAR POLYCARBONATE
- CM 216/317/418/519x163,5x284H

166

PENSILINE E COVERBICI
BUS AND BIKE SHELTERS



MOD. FENICE
PENSILINA ATTESA BUS/BUS STOP SHELTER

- COPERTURA E PARETE DI FONDO IN POLICARBONATO ALVEOLARE
- ROOF AND REAR PANELS IN ALVEOLAR POLYCARBONATE
- CM 301,6x150x250H



MOD. MIMOSA
COVERBICI BIFACCIALE /DOUBLE-SIDED BIKE SHELTER

- DA ASSEMBLARE/TO BE ASSEMBLED
- CM 256x298x282H (5+5 POSTI/SLOTS)



MOD. OLIMPIA
COVERBICI/BIKE SHELTER

- DISPONIBILE ANCHE IN VERSIONE BIFACCIALE
- AVAILABLE ALSO IN DOUBLE-SIDED VERSION
- CM 250x250x249H (5 POSTI/SLOTS)



167

GRIGLIE PER ALBERI
TREE GRILLES

GRIGLIE PER PROTEZIONE ALBERI

- SONO PRODOTTE IN VARI MODELLI DI FORMA QUADRATA O CIRCOLARE IN GHISA VERNICIATA
- AVAILABLE IN ROUND OR SQUARE SHAPE IN PAINTED CAST IRON

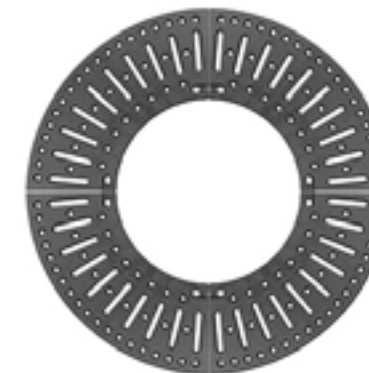
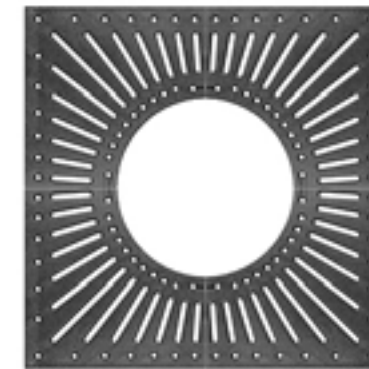

GHISA VERNICIATA/PAINTED CAST IRON

- CM 80x80 FORO/APERTURE Ø40 (4 PZ/PCS) - KG 37
- CM Ø100 FORO/APERTURE Ø50 (4 PZ/PCS) - KG 52
- CM Ø100 FORO/APERTURE Ø70 (4 PZ/PCS) - KG 39
- CM 100x100 FORO/APERTURE Ø50 (4 PZ/PCS) - KG 74
- CM 120x120 FORO/APERTURE Ø100 (4 PZ/PCS) - KG 67
- CM Ø150 FORO/APERTURE Ø100 (4 PZ/PCS) - KG 81
- CM 180x180 FORO/APERTURE Ø150 (8 PZ/PCS) - KG 125



REGGIPIANTA/TREE GUARDS

- FORNITO IN VERSIONE ZINCATA A CALDO O ZINCATA E VERNICIATA DI COLORE GRIGIO.
- AVAILABLE IN HOT-DIP GALVANIZED STEEL OR IN GALVANIZED AND POWDER COATED STEEL (GREY COLOUR).
- Ø CM 50 ALLA BASE/BASE APERTURE x180H - KG 20
- Ø CM 30 ALLA SOMMITÀ/TOP APERTURE

DOG TOILET DOG WASTE BINS



MOD. DOG TOILET PREMIUM

- IN ACCIAIO ZINCATO E VERNICIATO A FORNO
- GALVANIZED AND POWDER COATED STEEL
- CM 40x25x180H - KG 35 - LT 30
- N.1000 SACCHETTI/DOG WASTE BAGS

MOD. DOG TOILET GREEN

- DISPENSER IN ACCIAIO PER SACCHETTI E CESTINO IN PLASTICA MONTATI SU PALO ZINCATO
- METAL BAG DISPENSER AND PLASTIC BIN MOUNTED ON A GALVANIZED POLE
- CM 45x40x170H - KG 15 - LT 50
- N.1000 SACCHETTI/DOG WASTE BAGS

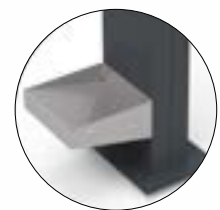

MOD. CLIO

- FONTANELLA DA ASSEMBLARE
- FOUNTAIN TO BE ASSEMBLED
- CM 15x15x100H - KG 35 (GRIGLIA/GRID: CM 45x25)
- ANCHE IN VERSIONE DOPPIA/DOUBLE-SIDED VERSION AVAILABLE
- ABBEVERATOIO ANIMALI/PET WATERER (OPTIONAL)



MOD. THALIA

- FONTANELLA DA ASSEMBLARE
- FOUNTAIN TO BE ASSEMBLED
- CM 25x25 - Ø15x100H - KG 35 (GRIGLIA/GRID: CM 45x25)
- IN ACCIAIO INOX/STAINLESS STEEL



MOD. NEW TUBE 2

- FONTANELLA DA ASSEMBLARE
- FOUNTAIN TO BE ASSEMBLED
- CM 20x20x101,5H - KG 15
- RUBINETTO A LEVA LEVER TAP (INCLUDED)



MOD. VAR

- FONTANELLA IN PIETRA RICOSTRUITA
- RECONSTRUCTED STONE FOUNTAIN
- CM 36x46x100H - KG 59
- RUBINETTO IN OTTONE/BRASS TAP (OPTIONAL)



FONTANELLE FOUNTAINS

MOD. AQUAVIVA

- FONTANA MONOLITICA DA INTERRARE PER CIRCA 10 CM NELLA PAVIMENTAZIONE
- ELEMENTO CENTRALE IN ACCIAIO INOX CON RUBINETTO CROMATO TEMPORIZZATO
- DISPONIBILE IN 4 COLORAZIONI ACRILICHE RESISTENTI ALL'ACQUA
- SINGLE-BLOCK CONCRETE FOUNTAIN TO BE PLACED 10 CM BELOW FINISHED GROUND LEVEL
- CENTRAL ELEMENT IN STAINLESS STEEL WITH A TIME FLOW PUSH-BUTTON IN CHROME PLATED STEEL
- AVAILABLE IN 4 STANDARD ACRYLIC WATER-RESISTANT COLOURS
- CM 80x50x114H (FUORI TERRA/ABOVE GROUND) - KG 410



MOD. MILANO

- FONTANELLA IN GHISA DAL DESIGN TRADIZIONALE, DOTATA DI RUBINETTO A PULSANTE (COLORE GRIGIO ANTRACITE)
- TRADITIONAL STYLE CAST IRON FOUNTAIN WITH A TIME FLOW PUSH-BUTTON. ANTHRACITE GREY COLOUR.
- MILANO MEDIA: CM 46x51x124H - KG 80



**MOD. SET GARDEN WOOD**

- SET TAVOLO CON 2 PANCHE REALIZZATO IN LEGNO DI PINO
- TIMBER PICNIC SET: 1 TABLE + 2 BENCHES IN PINE WOOD
- CM 210x180x86H - KG 115

**MOD. SET GARDEN STEEL+WOOD**

- SET TAVOLO CON 2 PANCHE REALIZZATO IN ACCIAIO + LEGNO DI PINO O ESOTICO
- PICNIC SET: 1 TABLE + 2 BENCHES IN STEEL AND PINE OR EXOTIC WOOD
- L = CM 200 - KG 174

**TAVOLO PIC-NIC CON PANCHE IN LEGNO INCORPORATE**

STRUTTURA REALIZZATA CON LEGNO DI PINO NORDICO, IMPREGNATO A PRESSIONE CON SALI MINERALI ATOSSICI. DISPONIBILE ANCHE CON RIPIANO ALLUNGATO PER L'ACCESSO AGEVOLE DI SEDIE A ROTELLE E PASSEGGINI.

PICNIC TABLE WITH INTEGRATED BENCHES

MADE ENTIRELY WITH VACUUM IMPREGNATED NORTHERN PINE WOOD USING NON-TOXIC MINERAL SALTS. ALSO AVAILABLE WITH EXTENDED END (INCLUSIVE VERSION)

- CM 195x146x74H - KG 80
- CM.240x146x75H - KG.90 (VERSIONE INCLUSIVA/INCLUSIVE VERSION)

TAVOLI TABLES

TAVOLO IN PIETRA RICOSTRUITA/CONCRETE TABLE

- TAVOLI ANDROMEDA/ANDROMEDA TABLES: CM 200x80x75H - KG 750

**OMEGA - TAVOLO DA PING-PONG/TABLE-TENNIS TABLE**

- SI COMPONE DI TRE SUPPORTI E DEL PIANO DI GIOCO IN DUE PARTI IN PIETRA RICOSTRUITA LEVIGATA. È DISPONIBILE RETE IN ACCIAIO INOX.
- WITH THREE SINGLE-BLOCK BASES AND A TWO-SLAB PLAYING TOP. STAINLESS STEEL NET AVAILABLE AS AN OPTION
- CM 274x152,5x76H - KG 1200

**TAVOLO ANDROMEDA QUADRATO + SEDUTA SINGOLA ERA**

- TAVOLO/TABLE: CM 80x80x75H - KG 420
- SEDUTA SINGOLA ERA/ ERA SINGLE SEAT: CM 45x45x45H - KG 130

È DISPONIBILE SCACCHIERA IN ALLUMINIO SERIGRAFATO CM 40x40
AVAILABLE OPTION: SILK-SCREENED ALUMINIUM CHESSBOARD CM 40x40



172

ISOLA ECOLOGICA
PRIVACY SCREENS FOR LITTER BINS



SISTEMA PREFABBRICATO CHE CONSENTE DI PROTEGGERE DAGLI URTI ACCIDENTALI E DI SCHERMARE LA VISTA DEI MEZZI PER LA RACCOLTA DEI RIFIUTI URBANI.

THE SIMPLE MODULARITY OF THIS PRODUCT, WHICH CAN ALSO BE FIXED ON PLANTERS, MAKES IT AN EASY AND POPULAR SOLUTION WHEN IN NEED OF SCREENING A GARBAGE/RECYCLE AREA FOR SAFETY AND PRIVACY REASONS.

- GRIGLIATO IN LEGNO DI PINO IMPREGNATO A PRESSIONE IN AUTOCLAVE, SIA DA FISSARE A TERRA CHE DA FISSARE ALLA FIORIERA IN CONGLOMERATO DA CM 140x50x50H
- PRESSURE-TREATED PINE SCREENS TO BE FIXED TO THE GROUND OR TO A CONCRETE PLANTER CM 140x50x50H



GAZEBO IN LEGNO DI PINO NORDICO IMPREGNATO IN AUTOCLAVE CON COPERTURA IN TELO PVC (OPPURE IN GUAINA ARDESIATA SU ASSITO IN LEGNO) COMPLETO DI FERRAMENTA IN ACCIAIO ZINCATO.

GAZEBO MADE OF SCANDINAVIAN VACUUM-PRESSURE IMPREGNATED PINE WOOD WITH PVC TOP (OR HARD TOP WITH ASPHALT SHINGLES). METAL PARTS ARE IN GALVANIZED STEEL.

- CM 525x525x238/317H

MODELLO DISPONIBILE IN ALTRE VERSIONI E DIMENSIONI. THIS MODEL IS OFFERED IN OTHER VERSIONS AND DIMENSIONS, PLEASE ENQUIRE WITHIN.



173

TOTEM E BACHECHE
TOTEMS & NOTICEBOARDS



MOD. NEW NETTUNO

TOTEM MONOFACCIALE O BIFACCIALE
SINGLE OR DOUBLE-SIDED TOTEM

- CM 90x20x204H - KG 95



MOD. SARIN

DOTATA DI ANTA CON VETRO E SERRATURA
EQUIPPED WITH GLAZED LOCKABLE CABINET

- CM 122/151/239x20x300H
- CM 250H (FUORI TERRA/ABOVE GROUND)

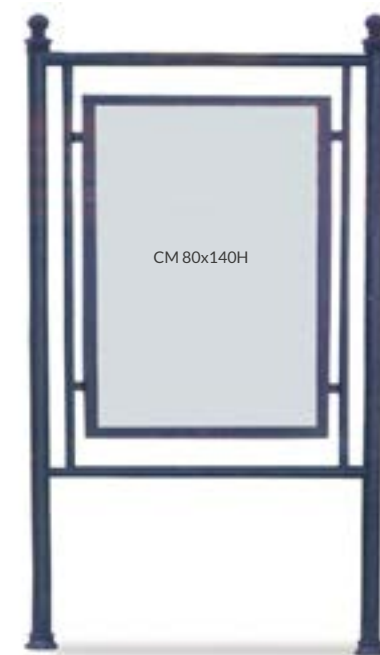

MOD. R

- CM 120x300H



MOD. F

- CM 160x300H

TRATTAMENTO DELLE PARTI IN LEGNO
TREATMENT OF WOODEN PARTS



IL LEGNO DI PINO NORDICO. VIENE IMPREGNATO SOTTOVUOTO IN AUTOCLAVE CON SALI MINERALI ATOSSICI, ESENTI DA CROMO E ARSENICO; QUESTO TRATTAMENTO GARANTISCE UNA PROTEZIONE PERMANENTE CONTRO FUNGHI, INSETTI, MUFFE E TUTTI I NEMICI BIOLOGICI DEL LEGNO.

SCANDINAVIAN PINE WOOD VACUUM-PRESSURE IMPREGNATED WITH NON-TOXIC MINERAL SALTS, FREE FROM CHROMIUM AND ARSENIC; THIS TREATMENT GRANTS A PERMANENT PROTECTION FROM FUNGI, MILDEW (MOLD) AND ALL WOOD PARASITES.

IL LEGNO ESOTICO VIENE TRATTATO CON OLIO TINTA NOCE.

THE EXOTIC WOOD, IS BRUSH PAINTED WITH OIL TO A "WALNUT" SHADE.

FINITURE SUPERFICI SU PANCHINE MONOBLOCCO
SURFACE FINISHINGS ON SINGLE-BLOCK BENCHES



RIVESTIMENTO ACRILICO PROTETTIVO COPRENTE, DOTATO DI ELEVATA RESISTENZA AGLI AGENTI ATMOSFERICI, PROTEGGE LE SUPERFICI EVITANDO LA FORMAZIONE DI MUFFE, ALGHE E MUSCHIO. IMPEDISCE LA CARBONATAZIONE DEL CALCESTRUZZO DOVUTA ALL'INQUINAMENTO AMBIENTALE.

ACRYLIC COATING - THIS FINISH IS ALKALI RESISTANT AND HIGHLY PROTECTIVE AGAINST THE MOST AGGRESSIVE ENVIRONMENTS. IT PREVENTS CARBONATION AS IT HAS EXCELLENT RESISTANCE TO CARBON DIOXIDE PENETRATION. IT WORKS AS SELF-CLEANING SEALANT WHILE ALSO PREVENTING THE GROWTH OF ALGAE, MILDEW, FUNGUS AND MOSS.

TRATTAMENTO DELLE PARTI METALLICHE
TREATMENT OF METAL PARTS



PER GARANTIRE UNA ADEGUATA RESISTENZA DEI COMPONENTI METALLICI ALL'ESTERNO **VENGONO IMPIEGATI I SEGUENTI TRATTAMENTI:**

- **CATAFORESI:** FONDO PROTETTIVO APPLICATO PER ELETTRODEPOSIZIONE CATODICA SUI MANUFATTI OPPURE PRIMER EPOSSIDICO IN POLVERE TERMOINDURENTE A BASE DI ZINCO;
- **VERNICIATURA A POLVERI POLIESTERE TERMOINDURENTE** PARTICOLARMENTE STUDIATE PER MANUFATTI DESTINATI ALL'ESTERNO.

TO ASSURE AN APPROPRIATE RESISTANCE OF METAL COMPONENTS TO THE ELEMENTS,

THE FOLLOWING TREATMENTS ARE CARRIED OUT:

- **CATAPHORESIS:** PROTECTIVE FINISH APPLIED THROUGH CATHODIC ELECTROPLATING OR ZINC-BASED THERMOSETTING EPOXY PRIMING;
- **PAINTING WITH THERMOSETTING POLYESTER POWDER** SPECIFIC FOR OUTDOOR USE.



QUESTA ETICHETTA INDIVIDUA I NOSTRI PRODOTTI CONFORMI AI "CRITERI AMBIENTALI MINIMI" (DPR 7/2/2023).

THIS LABEL IDENTIFIES OUR PRODUCTS THAT COMPLY WITH THE "MINIMUM ENVIRONMENTAL CRITERIA" (DPR 7/2/2023).



CALZOLARI HA A CUORE L'AMBIENTE E CREDE IN UNA GESTIONE RESPONSABILE DELLE FORESTE. PER QUESTO LA NOSTRA AZIENDA È CERTIFICATA FSC®. I NOSTRI PRODOTTI VENGONO REALIZZATI CON LEGNAME CERTIFICATO FSC®.

CALZOLARI CARES ABOUT THE ENVIRONMENT RESPONSIBLE MANAGEMENT OF THE FORESTS. THAT IS WHY THE COMPANY IS FSC® CERTIFIED. OUR PRODUCTS ARE MADE WITH FSC® CERTIFIED WOOD.

SOLO I PRODOTTI IDENTIFICATI COME TALI SONO CERTIFICATI FSC®. LOOK FOR OUR FSC®- CERTIFIED PRODUCTS.

NELLA STAMPA SU CARTA LA TONALITÀ DEI COLORI NON PUÒ ESSERE RIPRODOTTA FEDELMENTE. LE CARATTERISTICHE E I DATI TECNICI POSSONO VARIARE RISPETTO A QUANTO DESCRITTO NEL PRESENTE CATALOGO. LA CALZOLARI LAVORA COSTANTEMENTE AL PERFEZIONAMENTO DI TUTTI I MODELLI PRODOTTI. TUTTE LE PARTI METALLICHE VERNICIATE A FORNO SONO REALIZZATE IN COLORE ROSSO (RAL 3000), NERO, GRIGIO ANTRACITE (RAL 7021) ED EFFETTO CORTEN SU RICHIESTA. PER COLORAZIONI DIVERSE CONTATTARE LAZIENDA.

COLOURS MAY NOT BE PERFECTLY REPRODUCED IN PRINTING. CHARACTERISTICS AND TECHNICAL FEATURES MAY VARY FROM THOSE DESCRIBED IN THIS CATALOGUE. CALZOLARI CONSTANTLY SEEKS TO ACHIEVE PERFECTION IN ITS PRODUCTS. ALL THE POWDER COATED METAL PARTS ARE EITHER RED (RAL 3000), BLACK, ANTHRACITE GREY (RAL 7021) OR PAINTED WITH A WEATHERING STEEL EFFECT UPON REQUEST. FOR OTHER COLOURS, PLEASE CONTACT THE COMPANY.

COLORI DISPONIBILI
AVAILABLE COLOURS

COLORI BASE
BASIC COLOURS

- 18 CEMENTO BIANCO**
+ FINITURA ANTI-GRAFFITI TRASPARENTE
WHITE CONCRETE
+ CLEAR ANTI-GRAFFITI FINISH
- 19 CEMENTO GRIGIO NATURALE**
FAIR FACED NATURAL GREY CONCRETE
- 28 CEMENTO GRIGIO GRAFITE**
+ FINITURA ACRILICA TRASPARENTE
GRAPHITE GREY CONCRETE
+ CLEAR WATER-REPELLENT FINISH

RIVESTIMENTO ACRILICO COPRENTE*
+ FINITURA ACRILICA TRASPARENTE

SOLID COLOUR ACRYLIC PAINT*
+ CLEAR WATER-REPELLENT FINISH

* Altri colori a richiesta / More colours on request

7 BETON
CONCRETE

8 ROSSO MATTONE
BRICK RED

9 AVORIO
IVORY

10 ANTRACITE
ANTHRACITE

GHIAIETTO LAVATO
+ FINITURA ACRILICA TRASPARENTE
WASHED FINE GRAVEL
+ CLEAR WATER-REPELLENT FINISH

1 GRIGIO
GREY

2 BIANCO
WHITE

3 ROSA ANTICO
ANTIQUE PINK

4 OCRA AVORIO
IVORY OCHRE

CEMENTO MICROSABBIATO
+ FINITURA ANTI-GRAFFITI TRASPARENTE
+ CLEAR ANTI-GRAFFITI FINISH

29 GRIGIO PERLA
PEARL GREY

30 BIANCO MARMOREO
MARBLE WHITE

31 ROSA PASTELLO
BABY PINK

CEMENTO SABBIAIO
+ FINITURA ACRILICA TRASPARENTE
SAND-BLASTED CONCRETE
+ CLEAR WATER-REPELLENT FINISH

4/A SABBIA
SAND

5/A COTTO
TERRACOTTA

6/A PORFIDO
PORPHYRY

13 BOTTICINO BIANCO
WHITE

14 ROSA PRUN
PRUN PINK

15 TUFO
TUFF

16 GRANITO
GRANITE

20 NERO
BLACK

PIETRA RICOSTRUITA LEVIGATA
+ FINITURA ACRILICA TRASPARENTE
POLISHED RECONSTRUCTED STONE
+ CLEAR WATER-REPELLENT FINISH

18P PIETRA BIANCO CREMA
CREAMY WHITE STONE

20P PIETRA NERA
BLACK STONE

24 PIETRA BIANCA
WHITE STONE

25 PIETRA ROSA
PINK STONE

26 PIETRA VERDE
GREEN STONE

27 PIETRA GIALLO SIENA
YELLOW SIENA STONE



HEADQUARTER AND MANUFACTURING PLANT

INFORMAZIONI IMPORTANTI / IMPORTANT INFORMATION

CONGLOMERATO/PIETRA RICOSTRUITA

LA SUPERFICIE DEI MANUFATTI PUÒ PRESENTARE LIEVI CAVILLATURE O PICCOLI FORI CHE NON ALTERANO LA RESISTENZA E LA DURATA DEL PRODOTTO. TUTTE LE COLORAZIONI (ESCLUSO N.19) SONO TRATTATE CON RIVESTIMENTO ANTI GRAFFITI - IDROREPELENTE CHE PROTEGGE EFFICACEMENTE IL MANUFATTO DAGLI ALCALI E DAGLI AGENTI AGGRESSIVI PRESENTI NELL'ATMOSFERA (PIOGGE ACIDE) POICHÉ RIDUCE I FENOMENI DI CARBONATAZIONE DEL CALCESTRUZZO IN QUANTO POSSIEDE UN' ELEVATA RESISTENZA ALLA PENETRAZIONE DELL'ANIDRIDE CARBONICA; FAVORISCE INFINE L'EFFETTO AUTOPULENTE DELLA SUPERFICIE TRATTATA E IMPEDISCE LA FORMAZIONE DI ALGHE, MUFFE E MUSCHIO.

LEGNO

IL LEGNO IMPIEGATO È UN MATERIALE NATURALE ED È SOGGETTO A DEFORMAZIONI DA IMPUTARE ALLE CONDIZIONI ATMOSFERICHE. PICCOLE FESSURAZIONI, NODI E IMPERFEZIONI SONO DA CONSIDERARSI DEL TUTTO CONNATURATE ALLA NATURA DEL PRODOTTO. IL LEGNO TRATTATO SUBISCE UN NATURALE INGRIGIMENTO DOVUTO ALLE CONDIZIONI ATMOSFERICHE (AD ES. È PIÙ ACCENTUATO IN PRESENZA DI SALSEDINE MARINA) CHE PUÒ ESSERE COMPENSATO CON UN NUOVO TRATTAMENTO MANUTENTIVO CON IMPREGNANTE A CADENZA ANNUALE. PER I PREDETTI MOTIVI NON VENGONO FORNITE GARANZIE SULLA DURATA DEI TRATTAMENTI EFFETTUATI SULLE PARTI IN LEGNO.

METALLO

LE PARTI IN METALLO POSSONO SUBIRE UN DEGRADO REPENTINO SE COLLOCATE IN AMBIENTI FORTEMENTE INQUINATI O IN ZONE MARINE A CAUSA DELLA PRESENZA DI SALSEDINE. IN QUESTE CONDIZIONI NON VENGONO RILASCIATE GARANZIE SULLA DURATA DEL TRATTAMENTO DI VERNICIATURA STANDARD MA POSSONO ESSERE STUDIATE, DI VOLTA IN VOLTA, TRATTAMENTI ALTERNATIVI PERSONALIZZATI.

CONGLOMERATE/RECONSTRUCTED STONE

THE SURFACE OF THE PRODUCTS MAY EXHIBIT SMALL CRACKS OR SMALL HOLES THAT DO NOT CHANGE THE STRENGTH AND DURABILITY OF THE PRODUCT. ALL COLOURS (EXCLUDING NO.19) ARE TREATED WITH CLEAR ANTI-GRAFFITI TREATMENT AND WATER-REPELLENT ACRYLIC COATING THAT EFFECTIVELY PROTECTS THE PRODUCT FROM ALKALIS AND AGGRESSIVE AGENTS PRESENT IN THE ATMOSPHERE (ACID RAIN) BECAUSE IT REDUCES CARBONATION OF THE CONCRETE CONSIDERING IT A HIGH RESISTANCE TO PENETRATION OF CARBON DIOXIDE; FINALLY, IT PROMOTES THE SELF-CLEANING EFFECT OF THE TREATED SURFACE AND PREVENTS THE FORMATION OF ALGAE, MOULD, AND MOSS.

WOOD

THE WOOD USED IS A NATURAL MATERIAL AND IS SUBJECT TO DEFORMATION DUE TO WEATHER CONDITIONS. SMALL CRACKS, KNOTS AND IMPERFECTIONS ARE TO BE CONSIDERED ENTIRELY UNIQUE TO THE NATURE OF THE PRODUCT. THE TREATED WOOD UNDERGOES A NATURAL GREASING DUE TO WEATHER CONDITIONS (E.G., IT IS MORE CONSISTENT IN THE PRESENCE OF SEA SALTS) WHICH CAN BE COMPENSATED WITH A NEW MAINTENANCE TREATMENT WITH AN IMPREGNATOR ONCE A YEAR. FOR THE AFOREMENTIONED REASONS, NO GUARANTEE IS PROVIDED ON THE DURATION OF THE TREATMENTS ON THE WOODEN PARTS.

METAL

METAL PARTS MAY DETERIORATE SUDDENLY WHEN PLACED IN HEAVILY POLLUTED ENVIRONMENTS OR IN MARINE AREAS DUE TO THE PRESENCE OF SALTS. UNDER THESE CONDITIONS, NO GUARANTEE IS ISSUED ON THE DURATION OF THE STANDARD PAINTING TREATMENT, BUT CUSTOMISED ALTERNATIVE TREATMENTS CAN BE DESIGNED UPON REQUEST.

SIAMO PRESENTI SUL MERCATO ELETTRONICO PUBBLICA AMMINISTRAZIONE



GARANZIE

GLI STANDARD PRESTAZIONALI ADOTTATI GARANTISCONO PRODOTTI REALIZZATI AI MASSIMI LIVELLI QUALITATIVI. I NOSTRI CLIENTI SONO TUTELATI SIA DALLE NORME PREVISTE DAL SISTEMA DI QUALITÀ ISO 9001:2015, CHE DA UNA COSTANTE VERIFICA DELLE MATERIE PRIME, DEI SEMILAVORATI E DEI PRODOTTI FINITI PRIMA DI CIASCUNA CONSEGNA. TUTTI I NOSTRI PRODOTTI, OLTRE AD ESSERE GARANTITI PER IL PERIODO PREVISTO DALLA NORMATIVA VIGENTE, SONO COPERTI DA POLIZZA DI ASSICURAZIONE DELLA RESPONSABILITÀ CIVILE PER DANNI SUBITI DA TERZI A CAUSA DI DIFETTI DI PRODUZIONE.

CONSULENZA E ASSISTENZA POST-VENDITA

AVVALENDOSI DI UNA RETE COMMERCIALE DIFFUSA CAPILLARMENTE SUL TERRITORIO È POSSIBILE GARANTIRE IN POCHI GIORNI UN SOPRALLUOGO CHE SERVIRÀ AL NS. UFFICIO VENDITE PER ELABORARE PREVENTIVI MIRATI, PARTENDO DALLE ESIGENZE DEL CLIENTE. IN MOLTI CASI L'OFFERTA VIENE VISUALIZZATA MEDIANTE PROPOSTE GRAFICHE DETTAGLIATE. INFINE LA NOSTRA CONSULENZA COMPRENDE ANCHE LA MANUTENZIONE E IL RINNOVO DEI PRODOTTI PER GARANTIRNE LA MASSIMA DURATA IN CONDIZIONI OTTIMALI DI ESERCIZIO.

GUARANTEES

ADOPTED PERFORMANCE STANDARDS ASSURE TOP QUALITY PRODUCTS. OUR CUSTOMERS ARE PROTECTED BOTH BY THE REGULATIONS PROVIDED FOR BY ISO 9001:2015 QUALITY SYSTEM AND BY A CONSTANT CONTROL OF RAW MATERIALS, SEMI-FINISHED PRODUCTS AND FINISHED-PRODUCTS BEFORE EACH DELIVERY. FURTHER TO THE GUARANTEE FOR THE PERIOD OF TIME FIXED BY THE REGULATIONS IN FORCE, ALL OUR PRODUCTS ARE COVERED BY A THIRD-PARTY LIABILITY INSURANCE, IN CASE OF DAMAGES TO THIRD PARTIES RESULTING FROM ANY MANUFACTURING DEFECTS. ANY MANUFACTURING DEFECTS.

SALE AND AFTER-SALE CUSTOMER CARE

THANKS TO A WIDE NATIONAL AND INTERNATIONAL NETWORK OF SALES AGENTS AND REPRESENTATIVES, CALZOLARI IS ABLE TO PROVIDE QUOTATIONS ACCORDING TO ANY CUSTOMER REQUESTS. WE ARE ALSO ABLE TO PRODUCE DETAILED EXECUTIVE DRAWINGS FOR THE CLIENT'S FINAL APPROVAL IF NEEDED AND DESIRED. OUR AFTER-SALE CUSTOMER CARE INCLUDES HELP ON THE MAINTENANCE OF OUR PRODUCTS AND THE REPLACEMENT OF SPARE PARTS IN ORDER TO GUARANTEE A LONGER PRODUCT LIFE AT THE BEST POSSIBLE CONDITIONS.



A NORMA DI LEGGE È VIETATA LA RIPRODUZIONE ANCHE PARZIALE DI QUESTO CATALOGO. PER LE VOCI DI CAPITOLATO DETTAGLIATE E I DISEGNI TECNICI CONSULTATE IL SITO INTERNET, OPPURE INVIATECI UNA MAIL A INFO@CALZOLARISRL.IT
 UNAUTHORISED REPRODUCTION AND/OR DISTRIBUTION OF THE CONTENTS OF THIS SITE IN WHOLE OR IN PART BY ANY MEANS IS STRICTLY PROHIBITED WITHOUT THE PRIOR WRITTEN CONSENT OF CALZOLARI SRL. FOR FURTHER TECHNICAL DETAILS AND TECHNICAL DRAWINGS PLEASE SEE THE WEB SITE OR CONTACT US AT INFO@CALZOLARISRL.IT



VIA CADELLORA 4/6 | 46023 GONZAGA (MANTOVA) - ITALY
TEL. +39 0376 58274
CALZOLARIARREDOURBANO.EU | INFO@CALZOLARISRL.IT
PEC: CALZOLARISRL@CERT.POSTECERT.IT