

# 2021

GENERALE GENERAL CATALOGUE CATALOGU  
GESAMTKATALOG CATÁLOGO GENERAL CATALC  
LE GENERAL CATALOGUE CATALOGUE GENERA  
TALOG CATÁLOGO GENERAL CATALOGO GENE  
RAL CATALOGUE CATALOGUE GENERAL GESAM  
CATÁLOGO GENERAL CATALOGO GENERALE GE  
ALOGUE CATALOGUE GENERAL GESAMTKATALO  
GENERAL CATALOGO GENERALE GENERAL CA  
TALOGUE GENERAL GESAMTKATALOG CATÁLOG  
ATALOGO GENERALE GENERAL CATALOGUE CA  
ENERAL GESAMTKATALOG CATÁLOGO GENERA  
GENERALE **GENERAL CATALOGUE** CATALOGU  
GESAMTKATALOG CATÁLOGO GENERAL CATALC  
LE GENERAL CATALOGUE CATALOGUE GENERA  
TALOG CATÁLOGO GENERAL CATALOGO GENE  
RAL CATALOGUE CATALOGUE GENERAL GESAM  
CATÁLOGO GENERAL CATALOGO GENERALE GE  
ALOGUE CATALOGUE GENERAL GESAMTKATALO  
GENERAL CATALOGO GENERALE GENERAL CAT  
ALOGUE GENERAL GESAMTKATALOG CATÁLOG  
ATALOGO GENERALE GENERAL CATALOGUE CA  
ENERAL GESAMTKATALOG CATÁLOGO GENERA  
GENERALE GENERAL CATALOGUE CATALOGU  
GESAMTKATALOG CATÁLOGO GENERAL CATALC  
LE GENERAL CATALOGUE CATALOGUE GENERA  
TALOG CATÁLOGO GENERAL CATALOGO GENE  
RAL CATALOGUE CATALOGUE GENERAL GESAM

<b>9Cento</b> .....	/152
<b>Alpi</b> .....	/128
<b>Aran</b> .....	/072
<b>Artemis</b> .....	/026
<b>Back</b> .....	/134
<b>Beat</b> .....	/234
<b>Brystone</b> .....	/062
<b>Chorus</b> .....	/090
<b>Code</b> CONTRACT .....	/284
<b>Dolmix</b> .....	/034
<b>Dunstone</b> CONTRACT .....	/288
<b>Eclectic</b> .....	/174
<b>Element Design</b> .....	/222
<b>Element Lux</b> .....	/184
<b>Evoke</b> .....	/242
<b>Extreme</b> CONTRACT .....	/300
<b>Granigliati - linea tecnica</b> .....	/260
<b>Ikon</b> .....	/204
<b>Interno4</b> .....	/164
<b>K-Color</b> .....	/256
<b>Limes</b> .....	/042
<b>Londale</b> CONTRACT .....	/292
<b>Midlake</b> .....	/082
<b>Moov</b> .....	/212
<b>Noord</b> .....	/196
<b>Percorsi Extra</b> .....	/100
<b>Percorsi Quartz</b> .....	/112
<b>Percorsi Smart</b> .....	/120
<b>Point</b> CONTRACT .....	/280
<b>Sight</b> .....	/140
<b>Skywall</b> CONTRACT .....	/304
<b>Soul</b> .....	/250
<b>Sunrise</b> .....	/144
<b>Swisstone</b> CONTRACT .....	/296
<b>Ubik</b> .....	/052
<b>Urban</b> CONTRACT .....	/308

GRES PORCELLANATO  
PORCELAIN STONEWARE

---

# 2021

**Catalogo generale**  
*General catalogue*  
*Catalogue general*  
*Gesamtkatalog*  
*Catálogo general*

## INDICE GENERALE/

GENERAL INDEX / INDEX GÉNÉRAL /  
ALLGEMEINER INDEX / ÍNDICE GENERAL

### INTRODUZIONE / INTRODUCTION/ PRÉSENTATION/ VORSTELLUNG / INTRODUCCIÓN

Azienda & Made in Italy	/006
Greenthinking	/008
Gres Porcellanato Keope	/010
Destinazioni d'uso	/012
Match Lab & Indoor/Outdoor	/020

### COLLEZIONI / COLLECTIONS / COLLECTIONS / KOLLEKTIONEN / COLECCIONES

Stone effect	/024
Marble effect	/150
Concrete&Design effect	/194
Wood effect	/232
Colour effect	/254
120x278 6mm range	/264
K2 20mm range	/268
K3 30mm range	/274
Contract	/278

### AREA TECNICA / SPECS&TECH / DOMAINE TECHNIQUE / TECHNISCHER BEREICH / ÁREA TÉCNICA

Legenda & simbologia	/314
Tabelle gamma 2021	/316
Tabelle informazioni tecniche	/332
Tabella DIN51130-DIN51097	/346
Misure-pesi-imballi	/350
Certificazioni	/356
Manuale di posa, uso e manutenzione	/370
Condizioni generali di vendita	/388

## INDICE PER ISPIRAZIONE/

INDEX BY INSPIRATION / SOMMAIRE DES INSPIRATIONS /  
INDEX FÜR INSPIRATION / ÍNDICE POR INSPIRACIÓN

### STONE EFFECT

Alpi	/128
Aran	/072
Artemis	/026
Back	/134
Brystone	/062
Chorus	/090
Code CONTRACT	/284
Dolmix	/034
Dunstone CONTRACT	/288
Extreme CONTRACT	/300
Limes Quartz White   Quartz Multicolor   Porfido Cold   Porfido Warm	/042
Midlake Quartzgrey   Quartzbeige   Ardesia   Porfido	/082
Percorsi Extra Pietra di Faedis   Pietra di Barge   Pietra di Combe   Pietra di Vals	/100
Percorsi Quartz	/112
Percorsi Smart Pietra di Bagnolo   Pietra di Bressa   Pietra di Lavis	/120
Point CONTRACT	/280
Sight	/140
Sunrise	/144
Swisstone CONTRACT	/296
Ubik	/052

### MARBLE EFFECT

9Cento Ombra Moca   Raggio Verde   Alba Oro   Aurora Beige Riflesso Bianco   Metamorfosi	/152
Eclectic Mistiq White   Oniric White   Persian Grey   Pinstripe Dark	/174
Elements Lux Calacatta   Calacatta Gold   Silver Grey   Emperador   Crema Beige Port Laurent   Lincoln	/184
Interno4 Calacatta San Babila   Carnico Brera   Renoir Isola   Breccia Tortona	/164

### CONCRETE&DESIGN EFFECT

Elements Design	/222
Ikon	/204
Londale CONTRACT	/292
Moov	/212
Noord	/196
Skywall CONTRACT	/304
Urban CONTRACT	/308

### WOOD EFFECT

Beat	/234
Evoke	/242
Soul	/250

### COLOUR EFFECT

Granigliati-linea tecnica	/260
K-Color	/256

## INDICE PER FORMATO/

INDEX BY SIZE / INDEX PAR FORMAT

VERZEICHNIS DER FORMATE / ÍNDICE POR FORMATO

### 6 mm ▾

#### 120x278

9Cento	/152
Brystone	/062
Dolmix	/034
Eclectic	/174
Element Design	/222
Element Lux	/184
Ikon	/204
Interno4	/164
Moov	/212

### 9 mm ▾

#### 120x240

Element Lux	/184
Moov	/212

#### 30x240

Beat	/234
------	------

#### 80x160

Interno4	/164
----------	------

#### 120x120

9Cento	/152
Artemis	/026
Back	/134
Brystone	/062
Chorus	/090
Dolmix	/034
Eclectic	/174
Elements Design	/222
Elements Lux	/184
Ikon	/204
Interno4	/164
Moov	/212
Noord	/196
Ubik	/052

### 60x120

9Cento	/152
Aran	/072
Artemis	/026
Back	/134
Brystone	/062
Chorus	/090
Code CONTRACT	/284
Dolmix	/034
Dunstone CONTRACT	/288
Eclectic	/174
Element Design	/222
Element Lux	/184
Ikon	/204
Interno4	/164
Limes	/042
Londale CONTRACT	/292
Moov	/212
Noord	/196
Percorsi Extra	/100
Sunrise	/144
Swisstone CONTRACT	/296
Ubik	/052

### 30x120

9Cento	/152
Aran	/072
Artemis	/026
Beat	/234
Brystone	/062
Chorus	/090
Eclectic	/174
Evoke	/242
Ikon	/204
Interno4	/164
Moov	/212
Noord	/196
Ubik	/052

### 20x120

Beat	/234
Element Design	/222
Elements Lux	/184
Evoke	/242
Moov	/212

### 15x120

Evoke	/242
90x90	
Ikon	/204
80x80	
Artemis	/026
Brystone	/062
Interno4	/164
Noord	/196
40x80	
Artemis	/026
75x75	
Chorus	/090
Moov	/212
37,5x75	
Chorus	/090
60x60	
9Cento	/152
Aran	/072
Back	/134
Brystone	/062
Chorus	/090
Code CONTRACT	/284
Dolmix	/034
Dunstone CONTRACT	/288
Eclectic	/174
Elements Design	/222
Elements Lux	/184
Ikon	/204
Interno4	/164
Limes	/042
Londale CONTRACT	/292
Moov	/212
Noord	/196
Percorsi Extra	/100
Percorsi Quartz	/112
Percorsi Smart	/120
Sunrise	/144
Swisstone CONTRACT	/296
Ubik	/052
Urban CONTRACT	/308

### 30x60

Aran	/072
Back	/134
Brystone	/062
Chorus	/090
Code CONTRACT	/284
Dunstone CONTRACT	/288
Eclectic	/174
Elements Design	/222
Elements Lux	/184
Ikon	/204
Limes	/042
Londale CONTRACT	/292
Moov	/212
Noord	/196
Percorsi Extra	/100
Percorsi Quartz	/112
Percorsi Smart	/120
Point CONTRACT	/280
Sunrise	/144
Swisstone CONTRACT	/296
Ubik	/052
Urban CONTRACT	/308
14,7x60	
Moov	/212
9,7x60	
Aran	/072
Brystone	/062
Chorus	/090
Elements Design	/222
Ikon	/204
Moov	/212
Noord	/196
Ubik	/052
6,4x60	
Moov	/212
3,1x60	
Moov	/212
45x45	
Moov	/212

### 22,5x45,3

Limes	/042
Midlake	/082
30x30	
Alpi	/128
Granigliati /linea tec.	/260
Point CONTRACT	/280
15x30	
Alpi	/128
Percorsi Smart	/120
Point CONTRACT	/280
7,5x30	
Back	/134
Elements Design	/222
Moov	/212
22,5x22,5	
Limes	/042
Midlake	/082
20x20	
K-Color	/256
15x15	
Alpi	/128

### K2 20mm ▾

#### 120x240

Percorsi Extra	/100
Percorsi Smart	/120

#### 30x240

Percorsi Smart	/120
----------------	------

#### 120x120

Dolmix	/034
Moov	/212
Noord	/196
Percorsi Extra	/100
Percorsi Smart	/120

#### 60x120

Aran	/072
Chorus	/090
Elements Design	/222
Percorsi Extra	/100
Ubik	/052

#### 40x120

Beat	/234
------	------

#### 30x120

Evoke	/242
Percorsi Extra	/100
Soul	/250

#### 90x90

Ikon	/204
Moov	/212

#### 60x90

Brystone	/062
Midlake	/082
Limes	/042

### 45x90

Extreme CONTRACT	/300
Percorsi Extra	/100
Percorsi Smart	/120
80x80	
Brystone	/062
Noord	/196
Percorsi Extra	/100

### 60x60

Back	/134
Chorus	/090
Dolmix	/034
Extreme CONTRACT	/300
Ikon	/204
Moov	/212
Noord	/196
Percorsi Extra	/100
Percorsi Quartz	/112
Percorsi Smart	/120
Sight	/140
Skywall CONTRACT	/304
Swisstone CONTRACT	/296
Ubik	/052

### 30x60

Chorus	/090
Noord	/196

### 22,5x45,4

Midlake	/082
---------	------

### 22,5x22,5

Midlake	/082
---------	------

### K3 30mm ▾

#### 60x60

Moov	/212
Percorsi Extra	/100
Percorsi Smart	/120

# AZIENDA

COMPANY / SOCIÉTÉ / UNTERNEHMEN / EMPRESA



## IT\_

Siamo un'azienda ceramica italiana produttrice di gres porcellanato, con collezioni anche coordinate tra indoor e outdoor. La nostra esperienza storica nel mondo del design si fonda su una puntuale ricerca tecnologica e creativa, alimentata dalle relazioni con i nostri partner. Ogni prodotto porta con sé nel mondo i nostri valori antichi e nuovi. Dalle collezioni classiche fino a quelle più all'avanguardia, tutto segue un cammino sicuro in cui il dialogo tra nuove dimensioni di materia e architettura si fa sempre più intimo.

# MADE IN ITALY

MADE IN ITALY / MADE IN ITALY / MADE IN ITALY / MADE IN ITALY

## EN\_

*Through our everyday work, we renew the timeless prestige of the Made in Italy philosophy. Our manufacturing life connects to that of our land: research processes and product technologies evolve without sacrificing our ethics — decisions that have made us a demanding, transparent, and aware company over the decades. Keope products are the best synthesis of technological innovation, Italian artistic flair, and respect for people and the places they live, near or far.*

## FR\_

*Avec notre travail, nous renouvelons chaque jour le prestige indémodable de la philosophie du Made in Italy. La vie de notre manufacture est liée à celle du territoire : les processus de recherche et les technologies de production évoluent sans sacrifier les habitudes conscientes — celles-là mêmes qui, depuis des décennies, font de nous une société exigeante, transparente et consciente. Les produits Keope représentent la meilleure synthèse entre innovation technologique, créativité artistique italienne, respect pour les personnes et pour leurs lieux de vie, proches ou lointains.*

## DE\_

*Mit unserer Arbeit erneuern wir jeden Tag das zeitlose Prestige der Philosophie des Made in Italy. Die Entwicklung unseres Handwerks ist mit dem des Territoriums verbunden: Forschungsprozesse und Produktionstechnologien passen sich an, ohne auf bewusste Gewohnheiten zu verzichten, die uns seit Jahrzehnten zu einer anspruchsvollen, transparenten und bewussten Gesellschaft gemacht haben. Keope-Produkte sind die beste Synthese aus technologischer Innovation, italienischem künstlerischem Flair, Respekt vor den Menschen und den Umgebungen, in denen sie leben, ob nah oder fern.*

## ES\_

*Con nuestro trabajo, renovamos cada día el eterno prestigio de la filosofía Made in Italy. La vida de nuestra fábrica está ligada a la del territorio: los procesos de investigación y las tecnologías de producción evolucionan sin sacrificar conductas responsables, las mismas que durante décadas nos han convertido en una sociedad exigente, transparente y sensibilizada. Los productos Keope son la mejor síntesis de innovación tecnológica, inspiración artística italiana, respeto por las personas y los lugares en los que viven, cercanos o lejanos.*

## EN\_

*We're an Italian ceramics company producing porcelain stoneware with visual and mechanical continuity between indoor and outdoor spaces. Our tested design experience lies in careful technological and creative research, fueled by our business relationships. Each product brings our traditional and new values with it. From classic collections to the most avant-garde, everything follows a safe path in which the dialogue between new dimensions of material and architecture grows more and more intimate.*

## FR\_

*Nous sommes une entreprise de céramique italienne produisant du grès cérame, et nos collections peuvent notamment coordonner intérieur et extérieur. Notre expérience historique dans le monde du design se fonde sur une constante recherche technologique et créative, alimentée par nos relations avec nos partenaires. Chaque produit exprime nos valeurs, traditionnelles et nouvelles. Des collections classiques à celles plus à l'avant-garde, toute la production emprunte un chemin sûr où le dialogue entre les nouvelles dimensions de matière et d'architecture se fait de plus en plus intime.*

## DE\_

*Wir sind ein italienischer Keramikbetrieb, der in der Produktion von Feinsteinzeug spezialisiert ist. Unser Angebot umfasst auch koordinierte Kollektionen für den Innen- und Außenbereich. Unsere langjährige Erfahrung in der Designwelt basiert auf einer präzisen technologischen und kreativen Forschung, die auf die Beziehungen zu unseren Partnern stützt. Jedes Produkt bringt unsere alten und neuen Werte in die Welt. Von klassischen Kollektionen bis hin zu den hochmodernen, alles folgt einem sicheren Weg, auf dem der Dialog zwischen den neuen Dimensionen der Stofflichkeit und der Architektur immer inniger wird.*

## ES\_

*Somos una empresa italiana de cerámica que produce gres porcelánico, con colecciones a juego para interiores y exteriores. Nuestra experiencia histórica en el mundo del diseño se basa en una precisa investigación tecnológica y creativa, que se nutre de las relaciones con nuestros socios. Cada producto incorpora y muestra al mundo nuestros antiguos y nuevos valores. Desde colecciones clásicas a las más vanguardistas, todo sigue un camino seguro donde la interacción entre las nuevas dimensiones del material y la arquitectura se vuelve cada vez más íntima.*



## IT\_

Con il nostro lavoro, rinnoviamo ogni giorno il prestigio intramontabile della filosofia Made in Italy. La vita della nostra manifattura è legata a quella del territorio: processi di ricerca e tecnologie produttive si evolvono senza sacrificare abitudini consapevoli — le stesse che, da decenni, ci rendono una società esigente e trasparente. I prodotti Keope sono la migliori sintesi di innovazione tecnologica, estro artistico italiano, rispetto per le persone e per i luoghi in cui vivono, vicini o lontani.

# GREENTHINKING

GREENTHINKING / GREENTHINKING / GREENTHINKING / GREENTHINKING



IT\_

Il primo dovere di chi produce in grandi quantità è risparmiare risorse naturali. Per questo, recuperiamo tutta l'acqua impiegata; riduciamo il consumo di materie prime raccogliendo i materiali di scarto delle lavorazioni; riduciamo l'emissione di CO2 con impianti di cogenerazione che producono elettricità per autoconsumo; confezioniamo i prodotti con materiale riciclato. Le certificazioni green raccolte negli anni manifestano una chiara intenzione: rendere la sostenibilità una consuetudine trasversale a ogni ambito aziendale.

EN\_

The first duty of large manufacturers like us is to save natural resources. We recover all the production water we use; we reduce raw-material consumption by collecting post-processing waste elements; We reduce CO2 emissions by self-supplying energy through cogeneration plants; we pack products with recycled material. Our certifications history shows a clear plan: to make sustainability a rule that crosses every area of our business.

FR\_

Le premier devoir des producteurs de grosses quantités, c'est d'économiser les ressources naturelles. C'est dans ce but que nous récupérons toute l'eau utilisée, réduisons la consommation de matières premières en réutilisant les matériaux de rebut des processus de production, que nous réduisons l'émission de CO2 avec des installations de cogénération produisant leur propre électricité, que nous emballons les produits dans des matériaux recyclés. Les certifications green obtenues au fil des ans expriment une intention claire : faire de la durabilité une habitude transversale, incluant tous les domaines de l'entreprise.

DE\_

Die erste Pflicht derer, die in großen Mengen produzieren, ist die Schonung der natürlichen Ressourcen. Dazu gewinnen wir das gesamte verbrauchte Wasser zurück; wir reduzieren den Verbrauch von Rohstoffen, indem wir die Abfallstoffe aus der Verarbeitung recyceln; wir reduzieren CO2-Emissionen mit KWK-Anlagen, die Strom für den Eigenverbrauch produzieren; wir verpacken Produkte mit recyceltem Material. Die Green-Zertifikationen, die im Laufe der Jahre gesammelt wurden, zeigen eine klare Absicht: Die Nachhaltigkeit soll zu einer übergreifenden Gewohnheit in jedem Bereich des Unternehmens werden.

ES\_

La principal responsabilidad de quienes producen en grandes cantidades es ahorrar recursos naturales. Tanto es así que recuperamos toda el agua utilizada; reducimos el consumo de materias primas recuperando los materiales de desecho de la fabricación; reducimos la emisión de CO2 con plantas de cogeneración que producen electricidad para autoconsumo y embalamos los productos con material reciclado. Las certificaciones green obtenidas a lo largo de los años muestran una clara intención: hacer de la sostenibilidad una práctica transversal a todos los ámbitos de la empresa.



**84% ENERGIA AUTO  
PRODOTTA DA IMPIANTI  
DI COGENERAZIONE /**  
84% ENERGY  
SELF-PRODUCED BY  
COGENERATION PLANTS  
\* +24.000 MWh/year = 185.000



**MATERIE PRIME NON  
ESTRATTE GRAZIE AL  
RECUPERO DI SCARTI /**  
NON-EXTRACTED RAW  
MATERIALS THANKS  
TO THE RECOVERY OF  
SCRAPS  
\*18.408 t = 570



**ACQUE DI PROCESSO DA  
ALTRI STABILIMENTI /**  
PROCESS WATER FROM  
OTHER FACTORIES  
\* +5.000.000 L = 3.000.000



**100% ACQUE REFLUE  
RECUPERATE /**  
100% RECOVERED  
WASTE WATER



**100% SCARTI CRUDI  
RECUPERATI /**  
100% RECOVERED RAW  
SCRAPS



**100% PALLET FAO /**  
100% FAO PALLETS



**98% RIFIUTI AVVIATI  
A RACCOLTA  
DIFFERENZIATA /**  
98% WASTE SENT TO  
SEPARATE COLLECTION



**ENERGIA AUTO  
PRODOTTA DA  
FOTOVOLTAICO /**  
SELF-PRODUCED  
ENERGY BY PV PLANT

PEF

CAM  
COMPLIANT

FDES  
VÉRIFIÉE

EPD

HPD

LEED  
COMPLIANT

\* Dati riferiti al 2018 / Data referring to year 2018

# VANTAGGI DEL GRES PORCELLANATO KEOPE

PORCELAIN STONEWARE / LE GRÈS CÉRAME KEOPE / KEOPE FEINSTEINZEUG / EL GRES PORCELÁNICO KEOPE



**RESISTENTE A SFORZI  
ED ABRASIONI /**  
*RESISTANT TO STRESSES  
AND ABRASION*

500 Kg/cm<sup>2</sup> di pressatura meccanica  
e cottura a 1.250°C /  
500 kg/cm<sup>2</sup> of mechanical pressing  
and firing at 1250°C



**STABILE  
CROMATICAMENTE /**  
*CHROMATICALLY STABLE*

Inalterabile da agenti atmosferici  
e smog / *unchanged by weather  
agents and smog*



**RESISTENTE A GELO E  
SHOCK TERMICI /**  
*RESISTANT TO FROST  
AND SUDDEN THERMAL  
CHANGES*



**ANTISDRUCCIOLO /**  
*ANTI-SLIP*

Per ambienti bagnati e outdoor /  
*for outdoor and wet environments*



**ATOSSICA /**  
*NOT TOXIC*

Non emette fumi tossici /  
*does not emit toxic fumes*



**INATTACABILE DA  
FUNGHI E BATTERI /**  
*RESISTANT TO  
BACTERIA AND FUNGI*



**ASSORBIMENTO H<sub>2</sub>O  
NULLO /**  
*NULL H<sub>2</sub>O ABSORPTION*



**FACILMENTE  
PULIBILE /**  
*EASY TO CLEAN*



**INATTACCABILE  
DA ACIDI /**  
*NOT ATTACKED BY ACIDS*



**IGNIFUGA /**  
*FIREPROOF*



**RICICLABILE /**  
*RECYCLABLE*



**IT\_**

L'interazione esatta tra design e performance plasma la ceramica contemporanea. E viceversa: un ottimo prodotto, impiegato e testato in contesti evoluti, insegna qualcosa in termini di sicurezza, resistenza, igiene e versatilità. Per questo, oggi, nel nostro gres porcellanato si trova una sintesi di accorgimenti meccanici senza eguali né precedenti: ogni prodotto è inalterabile, ignifugo, atossico e riciclabile. In breve, assicura risultati esemplari in termini di durata e performance.

**EN\_**

Interaction between design and performance shapes contemporary ceramics. And vice versa: an outstanding product, used and tested in advanced contexts, teaches a lot about safety, resistance, hygiene, and versatility. For this reason, our porcelain stoneware tiles combine unprecedented mechanical patterns that make each product unalterable, fireproof, non-toxic, and recyclable — in other words, the ultimate sophistication in terms of duration and performance.

**FR\_**

L'interaction exacte entre design et performance façonne la céramique contemporaine. Et vice versa : un excellent produit, utilisé et testé dans des contextes d'évolution, nous apprend des choses en termes de sécurité, de résistance, d'hygiène et de versatilité. C'est pourquoi aujourd'hui, notre grès cérame représente un concentré d'astuces mécaniques sans égal et sans précédent : chaque produit est inaltérable, ignifuge, atoxique et recyclable. Bref, il garantit des résultats exemplaires en termes de durée et de performance.

**DE\_**

Das genaue Zusammenspiel von Design und Performance prägt die zeitgenössische Keramik. Und umgekehrt: Ein ausgezeichnetes Produkt, das in fortgeschrittenen Kontexten verwendet und getestet wird, gibt Aufschluss in Bezug auf Sicherheit, Widerstandsfähigkeit, Hygiene und Vielseitigkeit. Aus diesem Grund stellt unser Feinsteinzeug heute eine Synthese unvergleichlicher und beispielloser mechanischer Vorrichtungen dar: jedes Produkt ist unveränderlich, feuerfest, ungiftig und recycelbar. In anderen Worten, das Beste in Bezug auf Lebensdauer und Performance.

**ES\_**

La interacción exacta entre diseño y rendimiento da forma a la cerámica contemporánea. Y viceversa: siempre se puede aprender en términos de seguridad, resistencia, higiene y versatilidad de un producto excelente, utilizado y testado en contextos avanzados. Por eso, en nuestro gres porcelánico se aplica en la actualidad una síntesis de innovaciones mecánicas sin parangón ni precedentes: cada producto es inalterable, ignífugo, atóxico y reciclable. En resumen, asegura resultados ejemplares en términos de duración y rendimiento.



## IT\_

Le nostre collezioni rivestono interni ed esterni di ogni profilo — residenziale, commerciale, culturale e dedicato al benessere. Sono dimensioni stimolanti e confortevoli che nascono in equilibrio tra estetica tech e sapere tramandato, al fianco di architetti e designer di tutto il mondo. L'unione tra competenze ed elementi produce una linfa creativa insostituibile; per questo diamo estrema importanza alla connessione tra aperture e chiusure, geografie e strutture, campiture e trasparenze.

Project: **Budapest One Business Park**  
City: **Budapest (H)**  
Photo: **György Palkó**

## EN\_

Our collections cover interiors and exteriors of every profile — residential, commercial, cultural, and dedicated to wellness. Those are stimulating and comfortable dimensions born by balancing tech aesthetics and practiced knowledge, alongside international architects and designers. This interaction produces irreplaceable creative heart; that's why we value reciprocity between interiors and exteriors, environment and structure, partition and window.

## FR\_

Nos collections ornent des intérieurs et extérieurs en tous genres — résidentiels, commerciaux, culturels et dédiés au bien-être. Il s'agit d'espaces inspirants et confortables, qui voient le jour dans un équilibre entre esthétique technologique et savoir transmis, accompagnés d'architectes et designers du monde entier. L'union entre compétences et éléments produit une source de création irremplaçable ; c'est pourquoi nous attribuons une importance capitale à la connexion entre ouvertures et fermetures, entre géographies et structures, entre plénitude et transparence.

## DE\_

Unsere Kollektionen eignen sich bestens als Belag für den Innen- und Außenbereich in verschiedensten Umgebungen: Wohnen, Gewerbe, Kultur und Wellness. Es sind anregende und komfortable Dimensionen, die im Gleichgewicht zwischen technischer Ästhetik und überliefertem Know how entstanden sind und zusammen mit Architekten und Designern aus der ganzen Welt weiterentwickelt wurden. Die Verbindung zwischen Fähigkeiten und Elementen erzeugt eine unersetzliche kreative Ader; aus diesem Grund messen wir der Verbindung zwischen Öffnungen und Verschlüssen, Geographien und Strukturen, Hintergründen und Transparenzen größte Bedeutung bei.

## ES\_

Nuestras colecciones recubren interiores y exteriores de cualquier tipo: residenciales, comerciales, culturales y dedicados al bienestar. Son entornos estimulantes y confortables que ya surgen equilibrados en estética tecnológica y legado de conocimientos, acompañando a arquitectos y diseñadores de todo el mundo. La unión entre habilidades y elementos produce un espíritu creativo insustituible; por eso damos suma importancia al vínculo entre aperturas y cierres, relieves y estructuras, fondos y transparencias.







# OFFICE

Project: Gema Warehouse City: Modena (IT) Photo: Luciano Busani



# SHOP

Project: Italian Optic City: Sarnico (IT) Photo: Luciano Busani



Project: Longwood Dental City: Taipei (TW) Photo: Yiming Design



Project: Pasticceria Santa Giulia City: Cremona (IT) Photo: La bottega degli interni

# PUBLIC

Project: Mondo Juve Center City: Torino (IT) Photo: Luciano Busani



# RESTAURANT

Project: Sushic Asian Experience City: Varese (IT) Photo: Luciano Busani



Project: Piazza di Campigliano City: Salerno (IT) Photo: Luciano Busani



Project: Sushi Green City: Como (IT) Photo: Luciano Busani



# MATCH LAB

Il tuo consulente di arredo personalizzato, per creare abbinamenti straordinari per i tuoi spazi  
*Your customised interior design adviser, to create extraordinary pairings for your spaces*



IT\_

## Progetto Match Lab: 5 effetti, infinite combinazioni

Abbiamo creato un laboratorio virtuale per lavorare insieme, a distanza, in tempo reale: è Match Lab, applicazione gratuita per gli smartphone di chiunque abbia un progetto tra le mani. Match Lab studia le migliori combinazioni di materiali per pareti e rivestimenti e ne genera le anteprime in rendering.

Scarica l'app e accedi

1. Scegli l'ambiente da personalizzare
2. Scegli la superficie per iniziare gli abbinamenti
3. Combina i materiali secondo i suggerimenti dei nostri architetti
5. Perfeziona e definisci colori, formati e finiture con il tuo rivenditore.

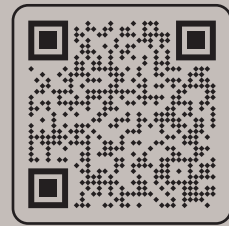

Scarica l'app

*Download the app / Télécharger l'appli /  
Laden Sie die App herunter / Descarga la aplicación*



EN\_

*Project Match Lab: 5 effects, endless combinations.*

*We have created a virtual laboratory to work together, remotely, in real time: we've called it Match Lab, a free App for smartphones and for anyone with a project to work on. Match Lab studies the best combinations of materials for walls and wall tiles, and generates previews in rendering.*

FR\_

*Projet Match Lab : 5 effets, des combinaisons infinies.*

*Nous avons créé un laboratoire virtuel pour travailler ensemble, à distance, en temps réel : c'est Match Lab, une application gratuite pour smartphones pour tous ceux qui ont un projet en tête. Match Lab étudie les meilleures combinaisons de matériaux pour revêtements muraux et de sol et génère les aperçus avec un rendu.*

DE\_

*Match Lab Projekt: 5 ästhetische Varianten, unendlich viele Kombinationen.*

*Wir haben ein virtuelles Labor bereit gestellt, um gemeinsam, aus der Ferne, in Echtzeit miteinander zu arbeiten: Match Lab ist eine kostenlose App für Smartphones, mit dem jeder am eigenen Projekt arbeiten kann. Match Lab analysiert die besten Materialkombinationen für Wände und Verkleidungen und generiert Vorschaubilder in Rendering.*

ES\_

*Proyecto Match Lab: 5 efectos, infinitas combinaciones.*

*Hemos creado un laboratorio virtual para trabajar juntos, a distancia, en tiempo real: es Match Lab, la aplicación gratuita para smartphone destinada a todo aquel que tenga un proyecto entre manos. Match Lab estudia las mejores combinaciones de materiales para pavimentos y revestimientos y genera su vista previa con una renderización.*

# INTERNO-ESTERNO IN CONTINUITÀ

*INDOOR-OUTDOOR CONTINUITY / CONTINUITÉ EXTERIEUR-INTERIEUR /  
AUBEN UND INNEN IN KONTINUITÄT / SUPERFICIES CONTINUAS EXTERNOS-INTERNOS*

EN\_

*We clad indoor and outdoor floor tiles completely, as far as architecture and landscape allow us, under the banner of perfect continuity. Technology allows our ceramic tile surfaces to modulate the thickness, finishing and dimensions continuously, allowing settings to stretch out beyond walls, glass walls and windows. With just one rule to follow: retaining a pure and unmistakable identity, made of increasingly superior stylistic choices and technical performance levels.*

FR\_

*Nous revêtons entièrement les sols intérieurs et extérieurs, dans la mesure où l'architecture et le cadre le permettent, avec une continuité parfaite. La technologie permet à nos surfaces céramiques de moduler en permanence les épaisseurs, finitions et dimensions pour franchir les espaces au-delà des parois, baies vitrées et fenêtres. Un seul mot d'ordre: conserver une identité pure et incomparable, faite de choix stylistiques et de performances techniques toujours plus élevées.*

DE\_

*Boden- und Wandbeläge für den Innen- und Außenbereich, soweit es Architektur und Landschaft zulassen, im Zeichen der perfekten Kontinuität. Die Technologie ermöglicht es unseren keramischen Oberflächen, die Stärke, die Oberflächenfinishes und die Formate kontinuierlich zu modulieren, um Umgebungen zu ermöglichen, die über Wände, Glaswände und Fenster hinausgehen. Nur eine Vorgabe muss berücksichtigt werden: eine reine und unverwechselbare Identität zu bewahren, die sich aus stilistischen Entscheidungen und immer höheren technischen Leistungen zusammensetzt.*

ES\_

*Revestimos completamente pavimentos de interior y exterior, hasta donde la arquitectura y el paisaje lo permiten, logrando siempre una perfecta continuidad. La tecnología permite a nuestras superficies cerámicas ajustar continuamente espesores, acabados y medidas para dejar que los espacios se desplacen más allá de paredes, ventanas y ventanales. Solo hay una regla: conservar una identidad pura e inconfundible, construida con opciones estilísticas y prestaciones técnicas cada vez más altas.*



IT\_

*Rivestiamo completamente pavimenti interni ed esterni, fin dove architettura e paesaggio lo consentono, nel segno della continuità perfetta. La tecnologia permette alle nostre superfici ceramiche di modulare continuamente spessori, finiture e dimensioni per lasciar sconfinare gli ambienti oltre pareti, vetrate e finestre. Con una sola regola: conservare un'identità pura e inconfondibile, fatta di scelte stilistiche e performance tecniche sempre più alte.*

# collections

Stone effect	/024
Marble effect	/150
Concrete&Design effect	/194
Wood effect	/232
Colour effect	/254
120x278 6mm range	/264
K2 20mm range	/268
K3 30mm range	/274
Contract	/278



# stone

EFFECT

026 / Artemis

034 / Dolmix

042 / Limes

052 / Ubik

062 / Brystone

072 / Aran

082 / Midlake

090 / Chorus

100 / Percorsi Extra

112 / Percorsi Quartz

120 / Percorsi Smart

128 / Alpi

134 / Back

140 / Sight

144 / Sunrise

ARTEMIS GREY  
120x120 (48"x48")

# artemis

5

COLORI/  
COLOURS  
COULEURS  
FARBE  
COLORES

7

FORMATI/  
SIZES  
FORMATS  
FORMATE  
FORMATOS

2

SUPERFICIE/  
FINISH  
FINITION  
OBERFLÄCHEN  
ACABADO

2

SPESSORE/  
THICKNESS  
ÉPAISSEUR  
STÄRKE  
ESPEJOR



stone effect | artemis



ARTEMIS WHITE  
120x120 (48"x48")

---

ARTEMIS ANTHRACITE  
120x120 (48"x48")

---







ARTEMIS SILVER  
80x80 (32"x32")  
40x80 (16"x32")



ARTEMIS BEIGE  
60x120 (24"x48")

# 5

## COLORI/

COLOURS / COULEURS / FARBE / COLORES

ARTEMIS ANTHRACITE V3

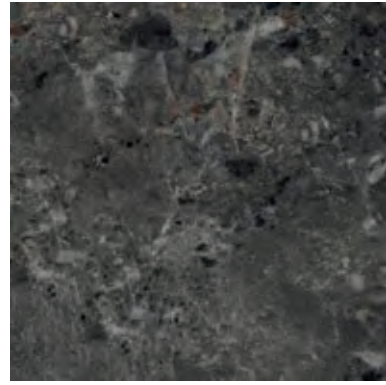

ARTEMIS BEIGE V3



ARTEMIS SILVER V3



ARTEMIS WHITE V3



ARTEMIS GREY V3

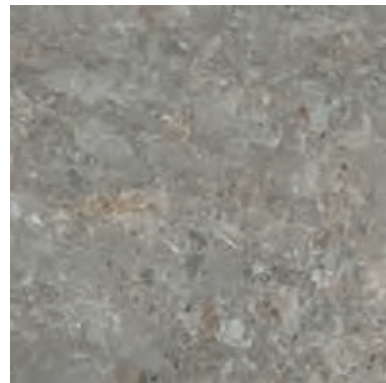

# 7

## FORMATI/

SIZES / FORMATS / FORMATE / FORMATOS



● 120x120 (48"x48") RT 9 mm

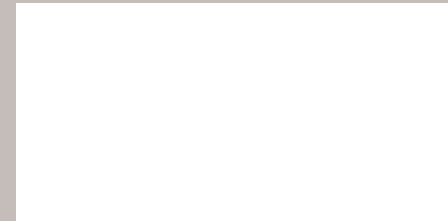

● 60x120 (24"x48") RT 9 mm  
▲ 60x120 (24"x48") RT ➔ K2 20 mm



● 30x120 (12"x48") RT 9 mm

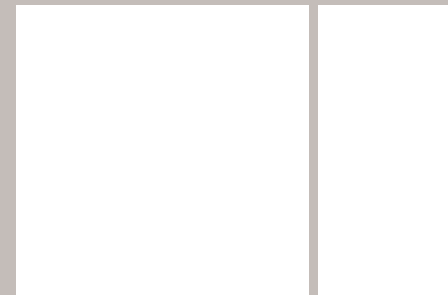

● 80x80 (32"x32") RT 9 mm ● 40x80 (16"x32") RT 9 mm

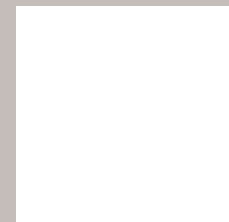

▲ 60x60 (24"x24") RT ➔ K2 20 mm

# 6

## PEZZI SPECIALI/

TRIMS / PIECES SPECIALES / FORMTEILE / PIEZAS ESPECIALES



**BATTISCOPA**  
BULLNOSE / PLINTHE / SOCKEL / RODAPIÉ  
● 4,6x120 (1<sup>13/16</sup>"x48") RT 9 mm  
● 7x80 (2<sup>3/4</sup>"x32") RT 9 mm

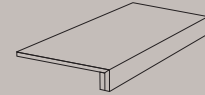

**SCALINO INCOLLATO**  
GLUED STEP TREAD / NEZ DE MARCHE COLLÉ / GEKLEBTE STUFENPLATTE / PELDAÑO CON PERFIL PEGADO  
● 33x60 (13"x24") RT 9 mm



**SCALINO ANGOLARE INCOLLATO**  
GLUED CORNER STEP TREAD / CARREAU DE MARCHE COLLÉ PIÈCE ANGULAIRE / GEKLEBTE STUFENPLATTE ECKSTÜCK / PELDAÑO ESQUINA CON PERFIL PEGADO  
● 33x33 (13"x13") RT 9 mm

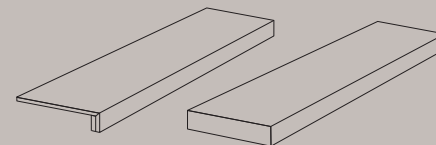

**SCALINO INCOLLATO**  
GLUED STEP TREAD / NEZ DE MARCHE COLLÉ / GEKLEBTE STUFENPLATTE / PELDAÑO CON PERFIL PEGADO  
● 33x120 (13"x48") RT 9 mm

**SCALINO ANGOLARE INCOLLATO**  
GLUED CORNER STEP TREAD / CARREAU DE MARCHE COLLÉ PIÈCE ANGULAIRE / GEKLEBTE STUFENPLATTE ECKSTÜCK / PELDAÑO ESQUINA CON PERFIL PEGADO  
● 33x120 (13"x48") RT 9 mm

## FORMATI

SIZES / FORMATS / FORMATE / FORMATOS

	120x120 (119,5x119,5)* 48"x48"	60x120 24"x48"	30x120 12"x48"	80x80 32"x32"	40x80 16"x32"	60x120 24"x48"	60x60 24"x24"
working size	1194x1194	596x1195	297x1195	795x795	396x795	596x1194	596x596
	RT	RT	RT	RT	RT	RT	RT
	9 mm	9 mm	9 mm	9 mm	9 mm	K2 20 mm	K2 20 mm
ARTEMIS ANTHRACITE	●	●	●	●	●		
ARTEMIS BEIGE	●	●	●	●	●	▲	▲
ARTEMIS GREY	●	●	●	●	●		
ARTEMIS SILVER	●	●	●	●	●	▲	▲
ARTEMIS WHITE	●	●	●	●	●		

\*Formato nominale / Nominal size / Format nominal / Nennformat / Formato nominal

● Natural R9 | ▲ Structured R11

# 17

## PEZZI SPECIALI K2/

TRIMS K2 / PIECES SPECIALES K2 / FORMTEILE K2 / PIEZAS ESPECIALES K2

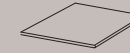

**ANGOLARE BORDO TORO**  
CORNER STEP TREAD / NEZ DE MARCHE ANGULAIRE / STUFENPLATTE ECKSTÜCK / ANGULAR CANTO ROMO  
▲ 30x30 (16"x16") RT 20 mm

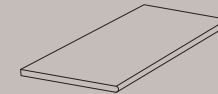

**GRADINO BORDO TORO**  
ROUNDED STEP TREAD / NEZ DE MARCHE ARRONDI / GERUNDET STUFENPLATTE / PELDAÑO CANTO ROMO  
▲ 60x120 (24"x48") RT 20 mm  
▲ 30x120 (12"x48") RT 20 mm  
▲ 30x60 (12"x24") RT 20 mm

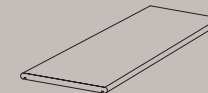

**TOP BORDO TORO**  
TOP STEP TREAD / NEZ DE MARCHE HAUT / STUFENPLATTE TOP / TOP CANTO ROMO  
▲ 30x60 (12"x24") RT 20 mm

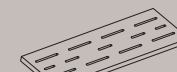

**GRIGLIA**  
GRID / GRIL / GRILL / REJILLA  
▲ 15x60 (6"x24") RT 20 mm

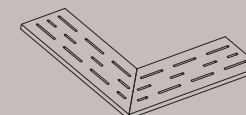

**ANGOLARE GRIGLIA**  
GRID / GRIL / GRILL / ANGULAR REJILLA  
▲ 15x60 (6"x24") RT 20 mm

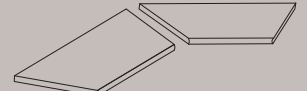

**ANGOLARE INTERNO BORDO TORO**  
INT. CORNER STEP TREAD / ANGLE INT. NEZ DE MARCHE / INNENECKTRITTSTUFE / ANG. INT. CANTO ROMO  
▲ 60x120 (24"x48") RT 20 mm  
▲ 30x120 (12"x48") RT 20 mm  
▲ 30x60 (12"x24") RT 20 mm

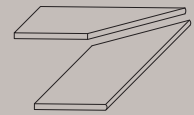

**ANGOLARE ESTERNO BORDO TORO**  
EXT. CORNER STEP TREAD / ANGLE EXT. NEZ DE MARCHE / AUSSENECKTRITTSTUFE / ANG. EXT. CANTO ROMO  
▲ 60x120 (24"x48") RT 20 mm  
▲ 30x120 (12"x48") RT 20 mm  
▲ 30x60 (12"x24") RT 20 mm

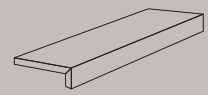

**TERMINALE L**  
GLUED "L" TERMINAL / TERMINAL "L" COLLÉ / "L" STÜCK FLIESE GEKLEBT / TERMINAL "L" (PEGADO)  
▲ 120x45x15 (48"x18"x6") RT 20 mm  
▲ 60x33x5 (24"x13"x2") RT 20 mm  
▲ 60x20x5 (24"x8"x2") RT 20 mm

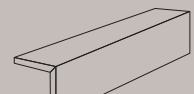

**CORDOLO L**  
GLUED "L" TERMINAL / TERMINAL "L" COLLÉ / "L" STÜCK FLIESE GEKLEBT / CANTONERA "L" (PEGADA)  
▲ 60x20x15 (24"x8"x6") RT 20 mm

stone effect | artemis

DOLMIX GREY  
120x278 (48"x110")

# dolmix

**3**

COLORI/  
COLOURS  
COULEURS  
FARBE  
COLORES

**6**

FORMATI/  
SIZES  
FORMATS  
FORMATE  
FORMATOS

**2**

SUPERFICI/  
FINISHES  
FINITIONS  
OBERFLÄCHEN  
ACABADOS

**3**

SPESSORI/  
THICKNESS  
ÉPAISSEUR  
STÄRKE  
ESPEJOR



stone effect | dolmix



DOLMIX DARK  
120x120 (48"x48")

DOLMIX LIGHT  
120x120 (48"x48")  
60x120 (24"x48")

stone effect | dolmix

# 5

**COLORI/**  
COLOURS / COULEURS / FARBE / COLORES

DOLMIX GREY **V2**

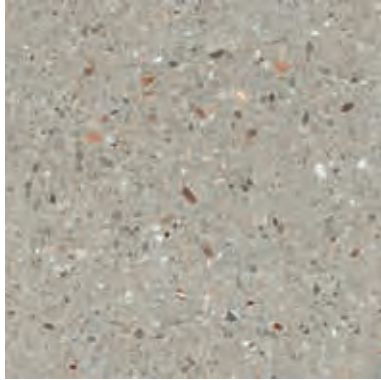

DOLMIX LIGHT **V2**

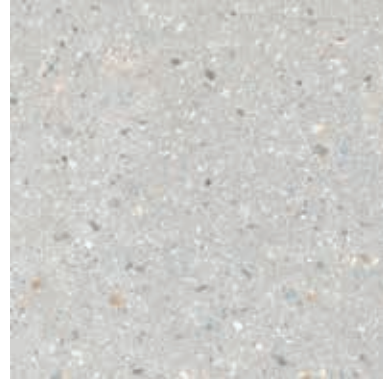

DOLMIX DARK **V2**

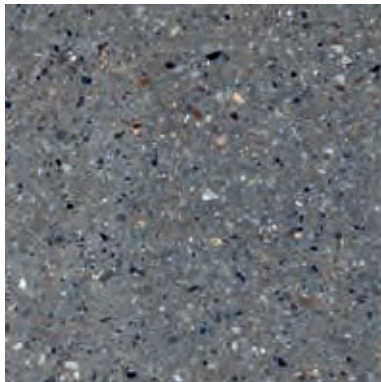

# 6

**FORMATI/**  
SIZES / FORMATS / FORMATE / FORMATOS

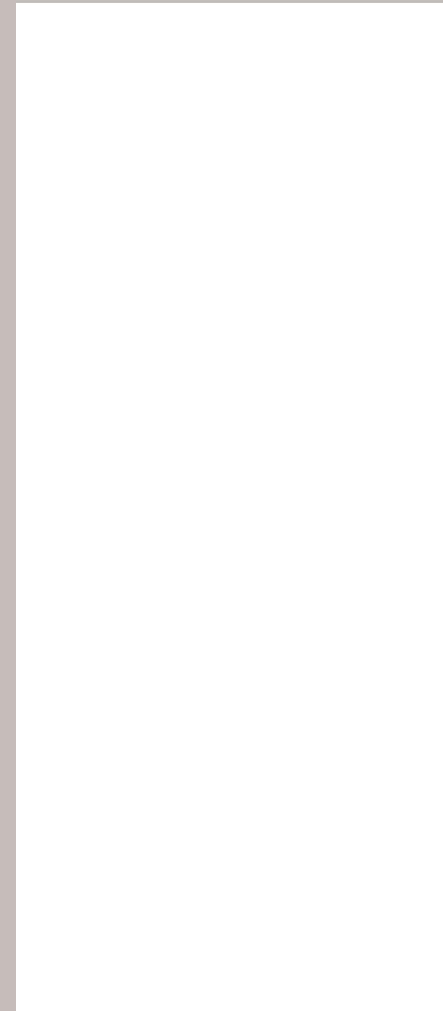

● 120x278 (48"x110") RT 6 mm



● 120x120 (48"x48") RT 9 mm  
▲ 120x120 (48"x48") RT **K2** 20 mm

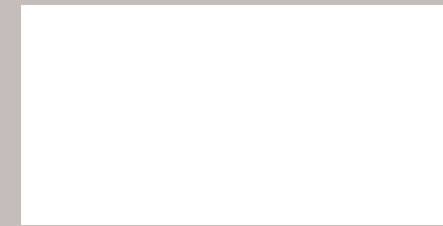

● 60x120 (24"x48") RT 9 mm

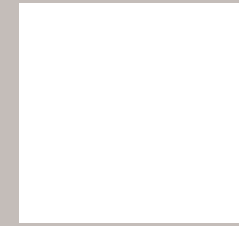

● 60x60 (24"x24") RT 9 mm  
▲ 60x60 (24"x24") RT **K2** 20 mm

● Natural R9 | ▲ Structured R11

# 6

## PEZZI SPECIALI/

TRIMS / PIECES SPECIALES / FORMTEILE /  
PIEZAS ESPECIALES



### BATTISCOPA

BULLNOSE / PLINTHE / SOCKEL / RODAPIÉ

● 4,6x120 (1<sup>13/16</sup>"x48") RT 9 mm

● 7,2x60 (2,8"x24") RT 9 mm

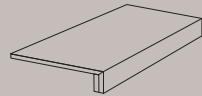

### SCALINO INCOLLATO

GLUED STEP TREAD / NEZ DE MARCHE COLLÉ / GEKLEBTE  
STUFENPLATTE / PELDAÑO CON PERFIL PEGADO

● 33x60 (13"x24") RT 9 mm

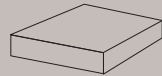

### SCALINO ANGOLARE INCOLLATO

GLUED CORNER STEP TREAD / CARREAU DE MARCHE  
COLLÉ PIÈCE ANGULAIRE / GEKLEBTE STUFENPLATTE  
ECKSTÜCK / PELDAÑO ESQUINA CON PERFIL PEGADO

● 33x33 (13"x13") RT 9 mm

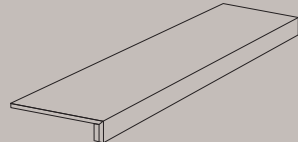

### SCALINO INCOLLATO

GLUED STEP TREAD / NEZ DE MARCHE COLLÉ / GEKLEBTE  
STUFENPLATTE / PELDAÑO CON PERFIL PEGADO

● 33x120 (13"x48") RT 9 mm

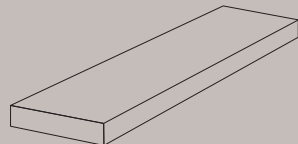

### SCALINO ANGOLARE INCOLLATO

GLUED CORNER STEP TREAD / CARREAU DE MARCHE COLLÉ  
PIÈCE ANGULAIRE / GEKLEBTE STUFENPLATTE  
ECKSTÜCK / PELDAÑO ESQUINA CON PERFIL PEGADO

● 33x120 (13"x48") RT 9 mm

# 17

## PEZZI SPECIALI K<sub>2</sub>/

TRIMS K<sub>2</sub> / PIECES SPECIALES K<sub>2</sub> / FORMTEILE K<sub>2</sub> /  
PIEZAS ESPECIALES K<sub>2</sub>

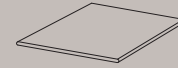

### ANGOLARE BORDO CON TORO

CORNER STEP TREAD / NEZ DE MARCHE ANGULAIRE /  
STUFENPLATTE ECKSTÜCK / ANGULAR CANTO ROMO

▲ 30x30 (12"x12") RT 20 mm

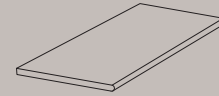

### GRADINO BORDO TORO

ROUNDED STEP TREAD / NEZ DE MARCHE ARRONDI /  
GERUNDET STUFENPLATTE / PELDAÑO CANTO ROMO

▲ 60x120 (24"x48") RT 20 mm

▲ 30x120 (12"x48") RT 20 mm

▲ 30x60 (12"x24") RT 20 mm

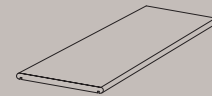

### TOP BORDO TORO

TOP STEP TREAD / NEZ DE MARCHE HAUT /  
STUFENPLATTE TOP / TOP CANTO ROMO

▲ 30x60 (12"x24") RT 20 mm

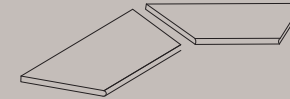

### ANGOLARE INTERNO BORDO CON TORO

INT. CORNER STEP TREAD / ANGLE INT. NEZ DE MARCHE /  
INNENECKTRITTSTUFE / ANG. INT. CANTO ROMO

▲ 60x120 (24"x48") RT 20 mm

▲ 30x120 (12"x48") RT 20 mm

▲ 30x60 (12"x24") RT 20 mm

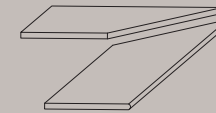

### ANGOLARE ESTERNO BORDO CON TORO

EXT. CORNER STEP TREAD / ANGLE EXT. NEZ DE MARCHE /  
AUSSENECKTRITTSTUFE / ANG. EXT. CANTO ROMO

▲ 60x120 (24"x48") RT 20 mm

▲ 30x120 (12"x48") RT 20 mm

▲ 30x60 (12"x24") RT 20 mm

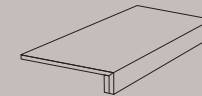

### TERMINALE L

GLUED "L" TERMINAL / TERMINAL "L" COLLÉ /  
"L" STÜCK FLIESE GEKLEBT / TERMINAL "L" (PEGADO)

▲ 120x45x15 (48"x18"x6") RT 20 mm

▲ 60x33x5 (24"x13"x2") RT 20 mm

▲ 60x20x5 (24"x8"x2") RT 20 mm

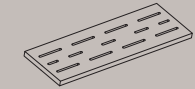

### GRIGLIA

GRID / GRIL / GRILL / REJILLA

▲ 15x60 (6"x24") RT 20 mm

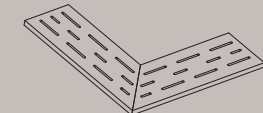

### ANGOLARE GRIGLIA

GRID / GRIL / GRILL / ANGULAR REJILLA

▲ 15x60 (6"x24") RT 20 mm

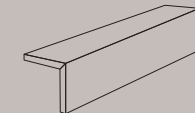

### CORDOLO L

GLUED "L" TERMINAL / TERMINAL "L" COLLÉ /  
"L" STÜCK FLIESE GEKLEBT / CANTONERA "L" (PEGADA)

▲ 60x20x15 (24"x8"x6") RT 20 mm

## FORMATI

SIZES / FORMATS / FORMATE / FORMATOS

	120x278 (119,5x278)* 48"x110"	120x120 (119,5x119,5)* 48"x48"	60x120 24"x48"	60x60 24"x24"	120x120 (119,5x119,5)* 48"x48"	60x60 24"x24"
working size	1194x2778	1194x1194	596x1195	596x596	1995x1195	596x596
	RT	RT	RT	RT	RT	RT
	6 mm	9 mm	9 mm	9 mm	K2 20 mm	K2 20 mm
DOLMIX GREY	●	●	●	●	▲	▲
DOLMIX LIGHT		●	●	●		
DOLMIX DARK		●	●	●		

\*Formato nominale / Nominal size / Format nominal / Nennformat / Formato nominal

● Natural R9 | ▲ Structured R11

# limes

QUARTZ WHITE  
60x90 (24"x36") K2 20 mm

**4**

COLORI/  
COLOURS  
COULEURS  
FARBE  
COLORES

**6**

FORMATI/  
SIZES  
FORMATS  
FORMATE  
FORMATOS

**2**

SUPERFICI/  
FINISHES  
FINITIONS  
OBERFLÄCHEN  
ACABADOS

**2**

SPESSORI/  
THICKNESS  
ÉPAISSEUR  
STÄRKE  
ESPEJOR



stone effect | limes



PORFIDO WARM  
22,5x45,3 (9"x18") -  
60x90 (24"x36") K2 20 mm

stone effect | limes





QUARTZ MULTICOLOR  
22,5x45,3 (9"x18")  
22,5x22,5 (9"x9")

---

PORFIDO COLD  
60x90 (24"x36") K2 20 mm

---



stone effect | limes

# 4

**COLORI/**  
COLOURS / COULEURS / FARBE / COLORES

PORFIDO COLD **V2**



PORFIDO WARM **V3**



QUARTZ WHITE **V3**



QUARTZ MULTICOLOR **V4**



# 6

**FORMATI/**  
SIZES / FORMATS / FORMATE / FORMATOS

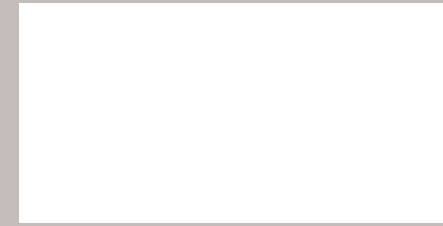

■ 60x120 (24"x48") RT 9 mm

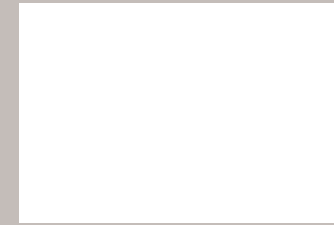

▲ 60x90 (24"x36") RT **K2** 20 mm

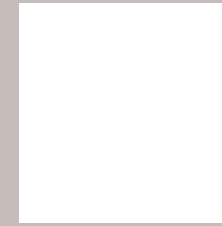

■ 60x60 (24"x24") RT 9 mm



■▲ 30x60 (12"x24") RT 9 mm



▲ 22,5x45,3 (9"x18") Not RT 9 mm



▲ 22,5x22,5 (9"x9") Not RT 9 mm

■ Structured R10 | ▲ Structured R11

# 2

## DECORI/

DECORS / PIECES SPECIALES / FORMTEILE /  
PIEZAS ESPECIALES

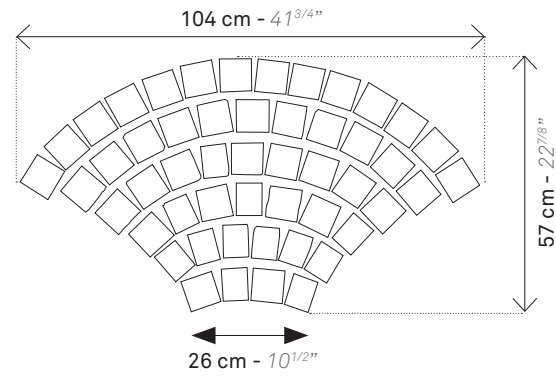

### CODA DI PAVONE

▲ 104x57 (41 3/4"x22 7/8") RT 9 mm  
(TOZZETTI: 6x7,5 - 21/2"x3" - 7,5x7,5 - 3"x3")



QUARTZ WHITE



PORFIDO COLD



QUARTZ MULTICOLOR



PORFIDO WARM

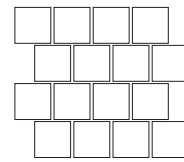

### MOSAICO BURATTATO

▲ 31x31 (12 1/2"x12 1/2") RT 9 mm  
(TOZZETTO: 7,5x7,5 - 3"x3")



QUARTZ WHITE



QUARTZ MULTICOLOR



PORFIDO COLD



PORFIDO WARM

# 8

## PEZZI SPECIALI/

TRIMS / PIECES SPECIALES / FORMTEILE /  
PIEZAS ESPECIALES



### BATTISCOPA

BULLNOSE / PLINTHE / SOCKEL / RODAPIÉ  
■▲ 7,2x60 (2,8"x24") RT 9 mm  
▲ 7,2x45,5 (2,8"x18") RT 9 mm



### SCALINO INCOLLATO

GLUED STEP TREAD / NEZ DE MARCHE COLLÉ / GEKLEBTE STUFENPLATTE / PELDAÑO CON PERFIL PEGADO  
■ 33x60 (13"x24") RT 9 mm



### SCALINO ANGOLARE INCOLLATO

GLUED CORNER STEP TREAD / CARREAU DE MARCHE COLLÉ  
PIÈCE ANGULAIRE / GEKLEBTE STUFENPLATTE ECKSTÜCK /  
PELDAÑO ESQUINA CON PERFIL PEGADO  
■ 33x33 (13"x13") RT 9 mm

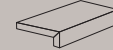

### TERMINALE L INCOLLATO

GLUED L TERMINAL / TERMINALE ELLE COLLÉ / L STÜCK  
FLIESE GEKLEBT / REMATE EN FORMA DE L PEGADO  
▲ 30x15x4 (12"x6"x1 9/16") RT 9 mm



### TERMINALE L MONOLITICO

L TERMINAL TEXTURED / TERMINALE ELLE STRUCTURÉ /  
STRUKTURIERTE L STÜCK FLIESE / REMATE EN FORMA DE L  
ESTRUCTURADO  
▲ 30x15x4 (12"x6"x1 9/16") RT 9 mm

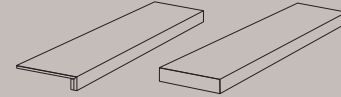

### SCALINO INCOLLATO

GLUED STEP TREAD / NEZ DE MARCHE COLLÉ / GEKLEBTE  
STUFENPLATTE / PELDAÑO CON PERFIL PEGADO  
■ 33x120 (13"x48") RT 9 mm

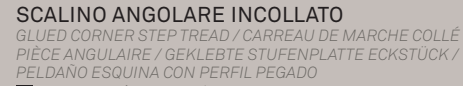

### SCALINO ANGOLARE INCOLLATO

GLUED CORNER STEP TREAD / CARREAU DE MARCHE COLLÉ  
PIÈCE ANGULAIRE / GEKLEBTE STUFENPLATTE ECKSTÜCK /  
PELDAÑO ESQUINA CON PERFIL PEGADO  
■ 33x120 (13"x48") RT 9 mm

### FORMATI

FORMATS / FORMATS / FORMATE / FORMATOS

	60x120 24"x48"	60x60 24"x24"	30x60 12"x24"	22,5x45,3 9"x18"	22,5x22,5 9"x9"	60x90 24"x36"
working size	596x1195	596x596	297x596			596x897
	RT	RT	RT	Not RT	Not RT	RT
	9 mm	9 mm	9 mm	9 mm	9 mm	K2 20 mm
QUARTZ WHITE	■	■	■▲	▲	▲	▲
QUARTZ MULTICOLOR	■	■	■▲	▲	▲	▲
PORFIDO COLD	■	■	■▲	▲	▲	▲
PORFIDO WARM	■	■	■▲	▲	▲	▲

■ Structured R10 | ▲ Structured R11

# 14

## PEZZI SPECIALI K2/

TRIMS K2 / PIECES SPECIALES K2 / FORMTEILE K2 /  
PIEZAS ESPECIALES K2

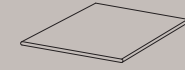

### ANGOLARE BORDO TORO

CORNER STEP TREAD / NEZ DE MARCHE ANGULAIRE /  
STUFENPLATTE ECKSTÜCK / ANGULAR CANTO ROMO  
▲ 30x30 (12"x12") RT 20 mm

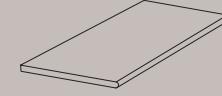

### GRADINO BORDO TORO

ROUNDED STEP TREAD / NEZ DE MARCHE ARRONDI /  
GERUNDET STUFENPLATTE / PELDAÑO CANTO ROMO  
▲ 45x90 (18"x36") RT 20 mm  
▲ 30x60 (12"x24") RT 20 mm

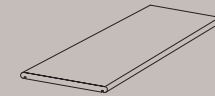

### TOP BORDO TORO

TOP STEP TREAD / NEZ DE MARCHE HAUT /  
STUFENPLATTE TOP / TOP CANTO ROMO  
▲ 30x60 (12"x24") RT 20 mm

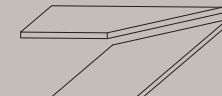

### ANGOLARE ESTERNO BORDO CON TORO

EXT. CORNER STEP TREAD / ANGLE EXT. NEZ DE MARCHE /  
AUSSENECKTRITTSTUFE / ANG. EXT. CANTO ROMO  
▲ 45x90 (18"x36") RT 20 mm  
▲ 30x60 (12"x24") RT 20 mm

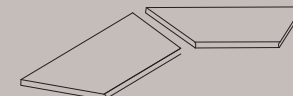

### ANGOLARE INTERNO BORDO CON TORO

INT. CORNER STEP TREAD / ANGLE INT. NEZ DE MARCHE /  
INNENECKTRITTSTUFE / ANG. INT. CANTO ROMO  
▲ 45x90 (18"x36") RT 20 mm  
▲ 30x60 (12"x24") RT 20 mm

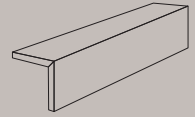

### CORDOLO L

GLUED "L" TERMINAL / TERMINAL "L" COLLÉ /  
"L" STÜCK FLIESE GEKLEBT / CANTONERA "L" (PEGADA)  
▲ 60x20x15 (24"x8" x6") RT 20 mm

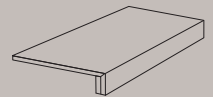

### TERMINALE L

GLUED "L" TERMINAL / TERMINAL "L" COLLÉ /  
"L" STÜCK FLIESE GEKLEBT / TERMINAL "L" (PEGADO)  
▲ 90x45x15 (36"x18" x6") RT 20 mm  
▲ 60x33x5 (24"x13" x2") RT 20 mm  
▲ 60x20x5 (24"x8" x2") RT 20 mm

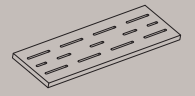

### GRIGLIA

GRID / GRIL / GRILL / REJILLA  
▲ 15x60 (6"x24") RT 20 mm



### ANGOLARE GRIGLIA

GRID / GRIL / GRILL / ANGULAR REJILLA  
▲ 15x60 (6"x24") RT 20 mm

stone effect | limes

# ubik

UBIK ANTHRACITE  
120x120 (48"x48")

---

**5**

COLORI/  
COLOURS  
COULEURS  
FARBE  
COLORES

**8**

FORMATI/  
SIZES  
FORMATS  
FORMATE  
FORMATOS

**2**

SUPERFICI/  
FINISHES  
FINITIONS  
OBERFLÄCHEN  
ACABADOS

**2**

SPESSORI/  
THICKNESS  
ÉPAISSEUR  
STÄRKE  
ESPESOR



stone effect | ubik



UBIK GREIGE  
30x120 (12"x48")



UBIK WALNUT  
60x120 (24"x48")

stone effect | ubik

UBIK GREY  
9,7x60 (37/8"x24")

ELEMENTS DESIGN BLACK  
LAVELLO A COLONNA / COLUMN SINK HOME DECOR  
50x50x85 (20"x20"x33<sup>3</sup>/<sub>8</sub>")

---

UBIK IVORY  
60x120 (24"x48")  
60x120 (24"x48") K2 20 mm

---



stone effect | ubik

# 5

**COLORI/**  
COLOURS / COULEURS / FARBE / COLORES

UBIK ANTHRACITE **V2**

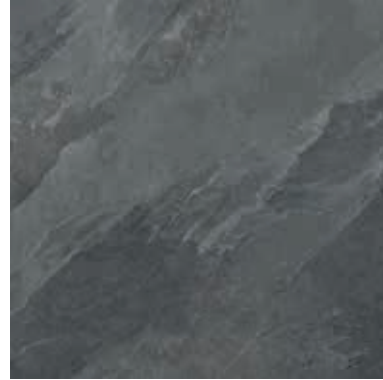

UBIK GREIGE **V2**



UBIK GREY **V2**



UBIK IVORY **V2**



UBIK WALNUT **V2**



# 8

**FORMATI/**  
SIZES / FORMATS / FORMATE / FORMATOS



● 120x120 (48"x48") RT 9 mm

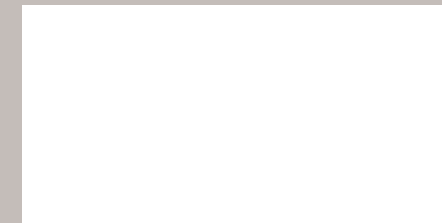

● 60x120 (24"x48") RT 9 mm  
▲ 60x120 (24"x48") RT **K2** 20 mm



● 30x120 (12"x48") RT 9 mm

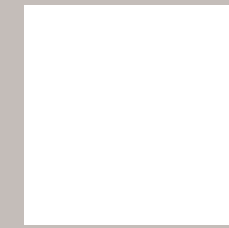

● 60x60 (24"x24") RT 9 mm  
▲ 60x60 (24"x24") RT **K2** 20 mm

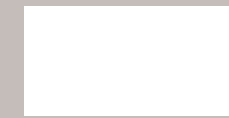

● ▲ 30x60 (12"x24") RT 9 mm



● 9,7x60 (3<sup>7/8</sup>"x24") RT 9 mm

● Natural R10 | ▲ Structured R11

# 2

## DECORI/

DECORS / PIECES SPECIALES / FORMTEILE /  
PIEZAS ESPECIALES

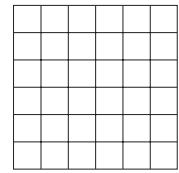

**MOSAICO** ● 30x30 (12"x12") RT 9 mm  
(TESSERE: 4,8x4,8 - 17/8"x17/8")

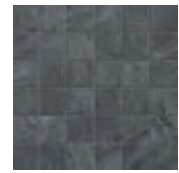

UBIK ANTHRACITE



UBIK GREIGE



UBIK GREY



UBIK IVORY

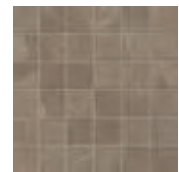

UBIK WALNUT



**LISTELLO UP** ● 9,7x60 (37/8"x24") RT 9 mm



UBIK ANTHRACITE



UBIK GREIGE



UBIK GREY



UBIK IVORY



UBIK WALNUT

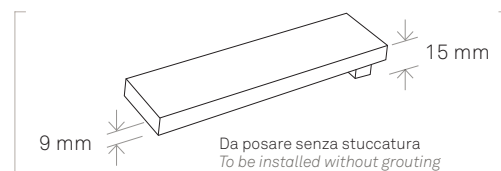

# 6

## PEZZI SPECIALI/

TRIMS / PIECES SPECIALES / FORMTEILE /  
PIEZAS ESPECIALES



**BATTISCOPA**  
BULLNOSE / PLINTHE / SOCKEL / RODAPIÉ  
● 4,6x120 (1<sup>13/16</sup>"x48") RT 9 mm  
● 7,2x60 (2,8"x24") RT 9 mm

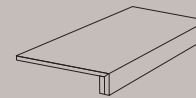

**SCALINO INCOLLATO**  
GLUED STEP TREAD / NEZ DE MARCHE COLLÉ / GEKLEBTE STUFENPLATTE / PELDAÑO CON PERFIL PEGADO  
● 33x60 (13"x24") RT 9 mm



**SCALINO ANGOLARE INCOLLATO**  
GLUED CORNER STEP TREAD / CARREAU DE MARCHE COLLÉ PIÈCE ANGULAIRE / GEKLEBTE STUFENPLATTE ECKSTÜCK / PELDAÑO ESQUINA CON PERFIL PEGADO  
● 33x33 (13"x13") RT 9 mm

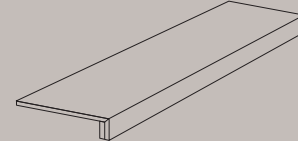

**SCALINO INCOLLATO**  
GLUED STEP TREAD / NEZ DE MARCHE COLLÉ / GEKLEBTE STUFENPLATTE / PELDAÑO CON PERFIL PEGADO  
● 33x120 (13"x48") RT 9 mm

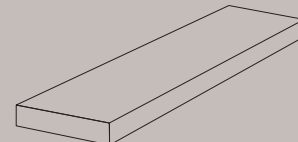

**SCALINO ANGOLARE INCOLLATO**  
GLUED CORNER STEP TREAD / CARREAU DE MARCHE COLLÉ PIÈCE ANGULAIRE / GEKLEBTE STUFENPLATTE ECKSTÜCK / PELDAÑO ESQUINA CON PERFIL PEGADO  
● 33x120 (13"x48") RT 9 mm

# 19

## PEZZI SPECIALI K<sub>2</sub>/

TRIMS K<sub>2</sub> / PIECES SPECIALES K<sub>2</sub> / FORMTEILE K<sub>2</sub> /  
PIEZAS ESPECIALES K<sub>2</sub>

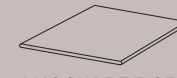

**ANGOLARE BORDO TORO**  
CORNER STEP TREAD / NEZ DE MARCHE ANGULAIRE / STUFENPLATTE ECKSTÜCK / ANGULAR CANTO ROMO  
▲ 30x30 (12"x12") RT 20 mm

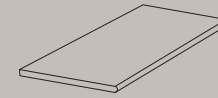

**GRADINO BORDO TORO**  
ROUNDED STEP TREAD / NEZ DE MARCHE ARRONDI / GERUNDET STUFENPLATTE / PELDAÑO CANTO ROMO  
▲ 60x120 (24"x48") RT 20 mm  
▲ 30x120 (12"x48") RT 20 mm  
▲ 30x60 (12"x24") RT 20 mm

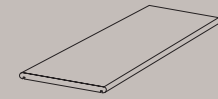

**TOP BORDO TORO**  
TOP STEP TREAD / NEZ DE MARCHE HAUT / STUFENPLATTE TOP / TOP CANTO ROMO  
▲ 30x60 (12"x24") RT 20 mm

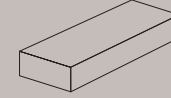

**GRADONE**  
▲ 120x35x15 (48"x14"x6") RT 20 mm  
▲ 60x35x15 (24"x14"x6") RT 20 mm

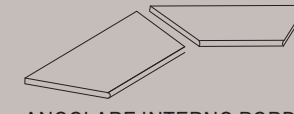

**ANGOLARE INTERNO BORDO CON TORO**  
INT. CORNER STEP TREAD / ANGLE INT. NEZ DE MARCHE / INNENECKTRITTSTUFE / ANG. INT. CANTO ROMO  
▲ 60x120 (24"x48") RT 20 mm  
▲ 30x120 (12"x48") RT 20 mm  
▲ 30x60 (12"x24") RT 20 mm

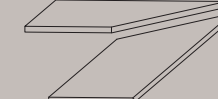

**ANGOLARE ESTERNO BORDO CON TORO**  
EXT. CORNER STEP TREAD / ANGLE EXT. NEZ DE MARCHE / AUSSENECKTRITTSTUFE / ANG. EXT. CANTO ROMO  
▲ 60x120 (24"x48") RT 20 mm  
▲ 30x120 (12"x48") RT 20 mm  
▲ 30x60 (12"x24") RT 20 mm

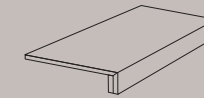

**TERMINALE L**  
GLUED "L" TERMINAL / TERMINAL "L" COLLÉ / "L" STÜCK FLIESE GEKLEBT / TERMINAL "L" (PEGADO)  
▲ 120x45x15 (48"x18"x6") RT 20 mm  
▲ 60x33x5 (24"x13"x2") RT 20 mm  
▲ 60x20x5 (24"x8"x2") RT 20 mm

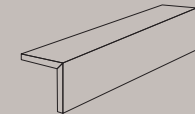

**CORDOLO L**  
GLUED "L" TERMINAL / TERMINAL "L" COLLÉ / "L" STÜCK FLIESE GEKLEBT / CANTONERA "L" (PEGADA)  
▲ 60x20x15 (24"x8"x6") RT 20 mm

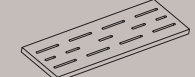

**GRIGLIA**  
GRID / GRIL / GRILL / REJILLA  
▲ 15x60 (6"x24") RT 20 mm

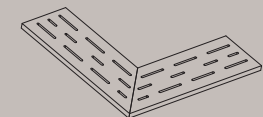

**ANGOLARE GRIGLIA**  
GRID / GRIL / GRILL / ANGULAR REJILLA  
▲ 15x60 (6"x24") RT 20 mm

## FORMATI

SIZES / FORMATS / FORMATE / FORMATOS

	120x120 (119,5x119,5)* 48"x48"	60x120 24"x48"	30x120 12"x48"	60x60 24"x24"	30x60 12"x24"	9,7x60 37/8"x24"	60x120 24"x48"	60x60 24"x24"
working size	1194x1194	596x1195	297x1195	596x596	297x596	97x596	596x1195	596x596
	RT	RT	RT	RT	RT	RT	RT	RT
	9 mm	9 mm	9 mm	9 mm	9 mm	9 mm	20 mm	20 mm
<b>UBIK ANTHRACITE</b>	●	●	●	●	●▲	●	▲	▲
<b>UBIK GREIGE</b>		●	●	●	●▲	●	▲	▲
<b>UBIK GREY</b>	●	●	●	●	●▲	●	▲	▲
<b>UBIK IVORY</b>	●	●	●	●	●▲	●	▲	▲
<b>UBIK WALNUT</b>		●	●	●	●▲	●	▲	▲

\*Formato nominale / Nominal size / Format nominal / Nennformat / Formato nominal

● Natural R10 | ▲ Structured R11



BRYSTONE IVORY  
120x278 (48"x110")

---

# brystone

**5**

COLORI/  
COLOURS  
COULEURS  
FARBE  
COLORES

**10**

FORMATI/  
SIZES  
FORMATS  
FORMATE  
FORMATOS

**3**

SUPERFICI/  
FINISHES  
FINITIONS  
OBERFLÄCHEN  
ACABADOS

**3**

SPESSORI/  
THICKNESS  
ÉPAISSEUR  
STÄRKE  
ESPESOR



stone effect | brystone

BRYSTONE AVANA  
60x120 (24"x48")

---



BRYSTONE WHITE  
60x120 (24"x48")

---



stone effect | brystone



BRYSTONE GOLD  
60x120 (24"x48")

---



BRYSTONE GREY  
120x120 (48"x48")

---

stone effect | brystone

# 5

**COLORI/**  
COLOURS / COULEURS / FARBE / COLORES

BRYSTONE WHITE V2



BRYSTONE IVORY V2



BRYSTONE GOLD V2



BRYSTONE GREY V2

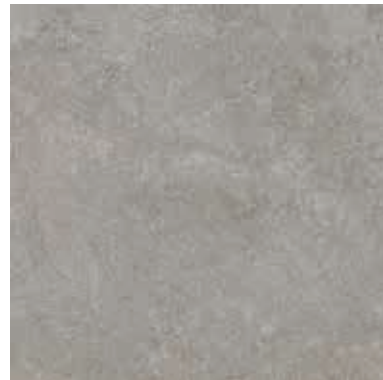

BRYSTONE AVANA V2



# 10

**FORMATI/**  
SIZES / FORMATS / FORMATE / FORMATOS



● 120x278 (48"x110") RT 6 mm



● 120x120 (48"x48") RT 9 mm

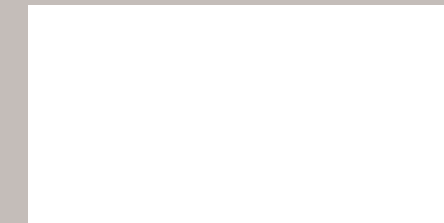

● ■ 60x120 (24"x48") RT 9 mm



● 30x120 (12"x48") RT 9 mm



▲ 60x90 (24"x36") RT ■ K2 20 mm



● 80x80 (32"x32") RT 9 mm  
▲ 80x80 (32"x32") RT ■ K2 20 mm

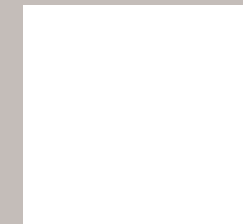

● ■ 60x60 (24"x24") RT 9 mm



● ■ 30x60 (12"x24") RT 9 mm



● 9,7x60 (3<sup>7/8</sup>"x24") RT 9 mm

stone effect | brystone

● Natural R9 | ■ Structured R10 | ▲ Structured R11

# 2

## DECORI/

DECORS / PIECES SPECIALES / FORMTEILE /  
PIEZAS ESPECIALES

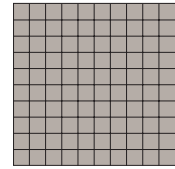

**MOSAICO ● 30x30 (12"x12") RT 9 mm**  
(TESSERE: 2,8x2,8 - 1<sup>1/8</sup>"x1<sup>1/8</sup>")



BRYSTONE WHITE



BRYSTONE IVORY



BRYSTONE GOLD



BRYSTONE GREY



BRYSTONE AVANA



**LISTELLO UP ● 9,7x60 (3<sup>7/8</sup>"x24") RT 9 mm**



BRYSTONE WHITE



BRYSTONE IVORY



BRYSTONE GOLD

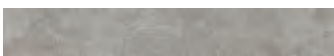

BRYSTONE GREY

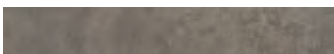

BRYSTONE AVANA

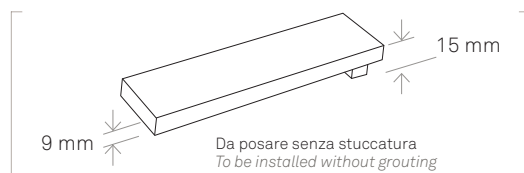

# 7

## PEZZI SPECIALI/

TRIMS / PIECES SPECIALES / FORMTEILE /  
PIEZAS ESPECIALES



**BATTISCOPA**  
BULLNOSE / PLINTHE / SOCKEL / RODAPIÉ  
● 4,6x120 (1<sup>13/16</sup>"x48") RT 9 mm  
● 7x80 (2<sup>3/4</sup>"x32") RT 9 mm  
● 7,2x60 (2,8"x24") RT 9 mm

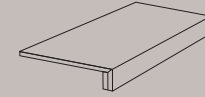

**SCALINO INCOLLATO**  
GLUED STEP TREAD / NEZ DE MARCHE COLLÉ / GEKLEBTE STUFENPLATTE / PELDAÑO CON PERFIL PEGADO  
● 33x60 (13"x24") RT 9 mm

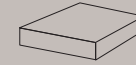

**SCALINO ANGOLARE INCOLLATO**  
GLUED CORNER STEP TREAD / CARREAU DE MARCHE COLLÉ PIÈCE ANGULAIRE / GEKLEBTE STUFENPLATTE ECKSTÜCK / PELDAÑO ESQUINA CON PERFIL PEGADO  
● 33x33 (13"x13") RT 9 mm

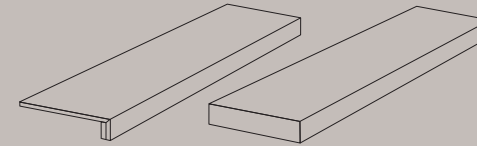

**SCALINO INCOLLATO**  
GLUED STEP TREAD / NEZ DE MARCHE COLLÉ / GEKLEBTE STUFENPLATTE / PELDAÑO CON PERFIL PEGADO  
● 33x120 (13"x48") RT 9 mm

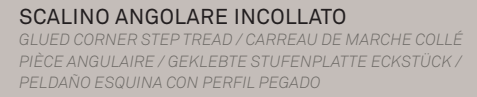

**SCALINO ANGOLARE INCOLLATO**  
GLUED CORNER STEP TREAD / CARREAU DE MARCHE COLLÉ PIÈCE ANGULAIRE / GEKLEBTE STUFENPLATTE ECKSTÜCK / PELDAÑO ESQUINA CON PERFIL PEGADO  
● 33x120 (13"x48") RT 9 mm

# 24

## PEZZI SPECIALI K<sub>2</sub>/

TRIMS K<sub>2</sub> / PIECES SPECIALES K<sub>2</sub> / FORMTEILE K<sub>2</sub> /  
PIEZAS ESPECIALES K<sub>2</sub>



**ANGOLARE BORDO TORO**  
CORNER STEP TREAD / NEZ DE MARCHE ANGULAIRE / STUFENPLATTE ECKSTÜCK / ANGULAR CANTO ROMO  
▲ 30x30 (12"x12") RT 20 mm  
▲ 40x40 (16"x16") RT 20 mm

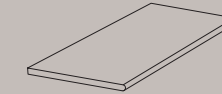

**GRADINO BORDO TORO**  
ROUNDED STEP TREAD / NEZ DE MARCHE ARRONDI / GERUNDET STUFENPLATTE / PELDAÑO CANTO ROMO  
▲ 45x90 (18"x36") RT 20 mm  
▲ 40x80 (16"x32") RT 20 mm  
▲ 30x60 (12"x24") RT 20 mm

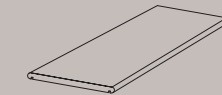

**TOP BORDO TORO**  
TOP STEP TREAD / NEZ DE MARCHE HAUT / STUFENPLATTE TOP / TOP CANTO ROMO  
▲ 30x60 (12"x24") RT 20 mm  
▲ 40x80 (16"x32") RT 20 mm

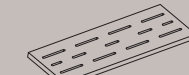

**GRIGLIA**  
GRID / GRIL / GRILL / REJILLA  
▲ 15x60 (6"x24") RT 20 mm  
▲ 20x80 (8"x32") RT 20 mm

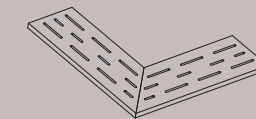

**ANGOLARE GRIGLIA**  
GRID / GRIL / GRILL / ANGULAR REJILLA  
▲ 15x60 (6"x24") RT 20 mm  
▲ 20x80 (8"x32") RT 20 mm

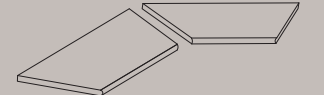

**ANGOLARE INTERNO BORDO TORO**  
INT. CORNER STEP TREAD / ANGLE INT. NEZ DE MARCHE / INNENECKTRITTSTUFE / ANG. INT. CANTO ROMO  
▲ 45x90 (18"x36") RT 20 mm  
▲ 40x80 (16"x32") RT 20 mm  
▲ 30x60 (12"x24") RT 20 mm

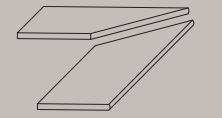

**ANGOLARE ESTERNO BORDO TORO**  
EXT. CORNER STEP TREAD / ANGLE EXT. NEZ DE MARCHE / AUSSENECKTRITTSTUFE / ANG. EXT. CANTO ROMO  
▲ 45x90 (18"x36") RT 20 mm  
▲ 40x80 (16"x32") RT 20 mm  
▲ 30x60 (12"x24") RT 20 mm



**TERMINALE L**  
GLUED "L" TERMINAL / TERMINAL "L" COLLÉ / "L" STÜCK FLIESE GEKLEBT / TERMINAL "L" (PEGADO)  
▲ 90x45x15 (36"x18"x6") RT 20 mm  
▲ 80x33x5 (32"x13"x2") RT 20 mm  
▲ 80x20x5 (32"x8"x2") RT 20 mm  
▲ 60x33x5 (24"x13"x2") RT 20 mm  
▲ 60x20x5 (24"x8"x2") RT 20 mm

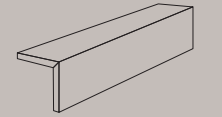

**CORDOLO L**  
GLUED "L" TERMINAL / TERMINAL "L" COLLÉ / "L" STÜCK FLIESE GEKLEBT / CANTONERA "L" (PEGADA)  
▲ 80x20x20 (32"x8"x8") RT 20 mm  
▲ 60x20x15 (24"x8"x6") RT 20 mm

## FORMATI

SIZES / FORMATS / FORMATE / FORMATOS

	120x278 (119,5x278)* 48"x110"	120x120 (119,5x119,5)* 48"x48"	60x120 24"x48"	30x120 12"x48"	80x80 32"x32"	60x60 24"x24"	30x60 12"x24"	9,7x60 3 <sup>7/8</sup> "x24"	60x90 24"x36"	80x80 32"x32"
working size	1194x2778	1194x1194	596x1195	297x1195	795x795	596x596	297x596	97x596	596x897	795x795
	RT 6 mm	RT 9 mm	RT 9 mm	RT 9 mm	RT 9 mm	RT 9 mm	RT 9 mm	RT 9 mm	RT 20 mm	RT 20 mm
<b>BRYSTONE WHITE</b>	●	●	●■	●	●	●■	●■	●		▲
<b>BRYSTONE IVORY</b>	●	●	●■	●	●	●■	●■	●	▲	
<b>BRYSTONE GOLD</b>	●	●	●■	●	●	●■	●■	●	▲	▲
<b>BRYSTONE GREY</b>		●	●■	●	●	●■	●■	●	▲	▲
<b>BRYSTONE AVANA</b>		●	●■	●	●	●■	●■	●		

\*Formato nominale / Nominal size / Format nominal / Nennformat / Formato nominal

● Natural R9 | ■ Structured R10 | ▲ Structured R11

ARAN GREY  
60x120 (24"x48") - 9,7x60 (3<sup>7</sup>/<sub>8</sub>"x24")

# aran

5

COLORI/  
COLOURS  
COULEURS  
FARBE  
COLORES

6

FORMATI/  
SIZES  
FORMATS  
FORMATE  
FORMATOS

2

SUPERFICI/  
FINISHES  
FINITIONS  
OBERFLÄCHEN  
ACABADOS

2

SPESSORI/  
THICKNESS  
ÉPAISSEUR  
STÄRKE  
ESPESOR



Thanks to: Divano Extrasoft Living Divani | Composizione vasi Adriani&Rossi, Zanetto



ARAN WALNUT  
60x120 (24"x48")

---



ARAN SILVER  
60x120 (24"x48") - 30x120 (12"x48")  
SCALINO INCOLLATO 33x120 (13"x48")

---

stone effect | aran

ARAN IVORY  
30x120 (12"x48") - 60x120 (24"x48")

---



ARAN ANTHRACITE  
30x120 (12"x48") - 60x120 (24"x48")

---



Thanks to: Poltrona Betty Max Design

stone effect | aran



# 5

## COLORI/

COLOURS / COULEURS / FARBE / COLORES

ARAN IVORY V2



ARAN WALNUT V2



ARAN GREY V2

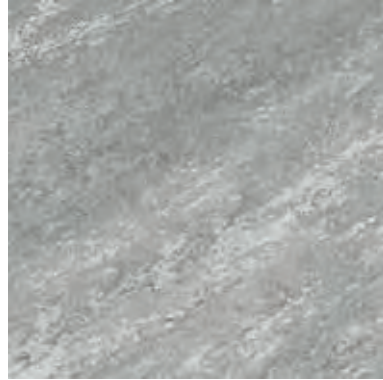

ARAN SILVER V2



ARAN ANTHRACITE V2

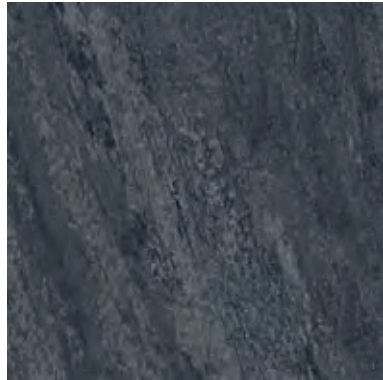

LEED  
COMPLIANT

# 6

## FORMATI/

SIZES / FORMATS / FORMATE / FORMATOS

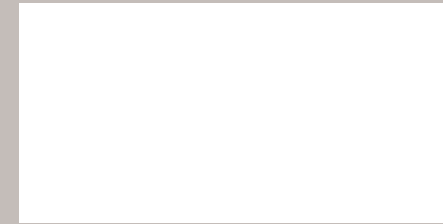

■ 60x120 (24"x48") RT 9 mm  
▲ 60x120 (24"x48") RT K2 20 mm



■ 30x120 (12"x48") RT 9 mm

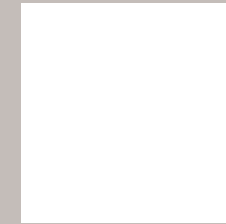

■ 60x60 (24"x24") RT 9 mm



■ ▲ 30x60 (12"x24") RT 9 mm



■ 9,7x60 (3<sup>7/8</sup>"x24") RT 9 mm

■ Structured R10 | ▲ Structured R11

# 3

## DECORI/

DECORS / PIECES SPECIALES / FORMTEILE /  
PIEZAS ESPECIALES

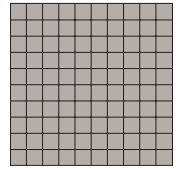

**MOSAICO ■ 30x30 (12"x12") RT 9 mm**  
(TESSERE: 2,8x2,8 - 11/16"x1 1/8")

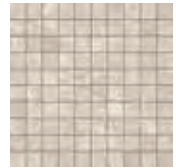

ARAN IVORY



ARAN WALNUT



ARAN GREY



ARAN SILVER

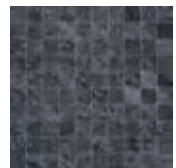

ARAN ANTHRACITE

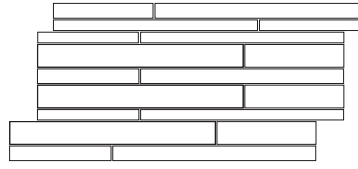

**MOSAICO MULTISPESSORE ■ 30x60 (12"x24") RT 9 mm**



ARAN IVORY



ARAN WALNUT



ARAN GREY



ARAN SILVER



ARAN ANTHRACITE



**LISTELLO UP ■ 9,7x60 (3 7/8"x24") RT 9 mm**



ARAN IVORY



ARAN WALNUT



ARAN GREY



ARAN SILVER



ARAN ANTHRACITE

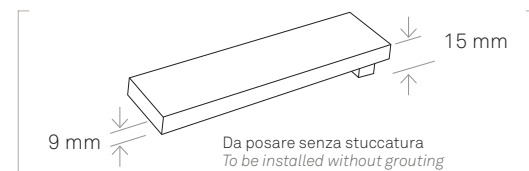

# 6

## PEZZI SPECIALI/

TRIMS / PIECES SPECIALES / FORMTEILE /  
PIEZAS ESPECIALES



**BATTISCOPA**  
BULLNOSE / PLINTHE / SOCKEL / RODAPIÉ  
■ 4,6x120 (1 13/16"x48") RT 9 mm  
■ 7,2x60 (2,8"x24") RT 9 mm

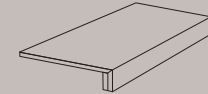

**SCALINO INCOLLATO**  
GLUED STEP TREAD / NEZ DE MARCHE COLLÉ / GEKLEBTE STUFENPLATTE / PELDAÑO CON PERFIL PEGADO  
■ 33x60 (13"x24") RT 9 mm



**SCALINO ANGOLARE INCOLLATO**  
GLUED CORNER STEP TREAD / CARREAU DE MARCHE COLLÉ / PIÈCE ANGULAIRE / GEKLEBTE STUFENPLATTE ECKSTÜCK / PELDAÑO ESQUINA CON PERFIL PEGADO  
■ 33x33 (13"x13") RT 9 mm

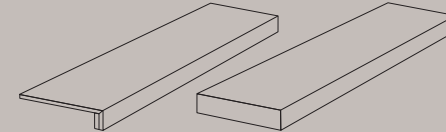

**SCALINO INCOLLATO**  
GLUED STEP TREAD / NEZ DE MARCHE COLLÉ / GEKLEBTE STUFENPLATTE / PELDAÑO CON PERFIL PEGADO  
■ 33x120 (13"x48") RT 9 mm

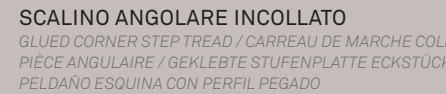

**SCALINO ANGOLARE INCOLLATO**  
GLUED CORNER STEP TREAD / CARREAU DE MARCHE COLLÉ / PIÈCE ANGULAIRE / GEKLEBTE STUFENPLATTE ECKSTÜCK / PELDAÑO ESQUINA CON PERFIL PEGADO  
■ 33x120 (13"x48") RT 9 mm

## FORMATI

FORMATS / FORMATS / FORMATE / FORMATOS

	60x120 24"x48"	30x120 12"x48"	60x60 24"x24"	30x60 12"x24"	9,7x60 3 7/8"x24"	60x120 24"x48"
working size	596x1195	297x1195	596x596	297x596	97x596	596x1195
	RT	RT	RT	RT	RT	RT
	9 mm	9 mm	9 mm	9 mm	9 mm	K2 20 mm
<b>ARAN IVORY</b>	■	■	■	■▲	■	
<b>ARAN WALNUT</b>	■	■	■	■▲	■	▲
<b>ARAN GREY</b>	■	■	■	■▲	■	
<b>ARAN SILVER</b>	■	■	■	■▲	■	▲
<b>ARAN ANTHRACITE</b>	■	■	■	■▲	■	▲

■ Structured R10 | ▲ Structured R11

# 9

## PEZZI SPECIALI K2/

TRIMS K2 / PIECES SPECIALES K2 / FORMTEILE K2 /  
PIEZAS ESPECIALES K2

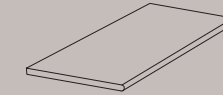

**GRADINO BORDO TORO**  
ROUNDED STEP TREAD / NEZ DE MARCHE ARRONDI / GERUNDET STUFENPLATTE / PELDAÑO CANTO ROMO  
▲ 60x120 (24"x48") RT 20 mm  
▲ 30x120 (12"x48") RT 20 mm

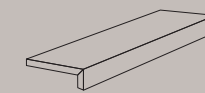

**TERMINALE L**  
GLUED "L" TERMINAL / TERMINAL "L" COLLÉ / "L" STÜCK FLIESE GEKLEBT / TERMINAL "L" (PEGADO)  
▲ 120x45x15 (48"x18"x6") RT 20 mm

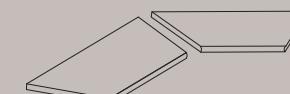

**ANGOLARE INTERNO BORDO TORO**  
INT. CORNER STEP TREAD / ANGLE INT. NEZ DE MARCHE / INNENECKTRITTSTUFE / ANG. INT. CANTO ROMO  
▲ 60x120 (24"x48") RT 20 mm  
▲ 30x120 (12"x48") RT 20 mm

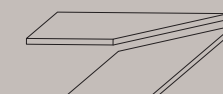

**ANGOLARE ESTERNO BORDO TORO**  
EXT. CORNER STEP TREAD / ANGLE EXT. NEZ DE MARCHE / AUSSENECKTRITTSTUFE / ANG. EXT. CANTO ROMO  
▲ 60x120 (24"x48") RT 20 mm  
▲ 30x120 (12"x48") RT 20 mm

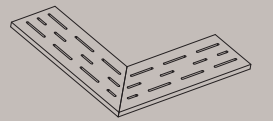

**ANGOLARE GRIGLIA**  
GRID / GRIL / GRILL / ANGULAR REJILLA  
▲ 15x60 (6"x24") RT 20 mm

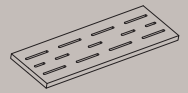

**GRIGLIA**  
GRID / GRIL / GRILL / REJILLA  
▲ 15x60 (6"x24") RT 20 mm

stone effect | aran

# midlake

MIDLAKE QUARTZGREY  
60x90 (24"x36") K2 20mm

---

**4**

COLORI/  
COLOURS  
COULEURS  
FARBE  
COLORES

**5**

FORMATI/  
SIZES  
FORMATS  
FORMATE  
FORMATOS

**1**

SUPERFICI/  
FINISHES  
FINITIONS  
OBERFLÄCHEN  
ACABADOS

**2**

SPESSORI/  
THICKNESS  
ÉPAISSEUR  
STÄRKE  
ESPESOR



MIDLAKE PORFIDO  
22,5x45,3 (9"x18") - 22,5x22,5 (9"x9")



MIDLAKE QUARTZBEIGE  
60x90 (24"x36") K2 20mm  
GRADINO BORDO TORO  
45x90 (18"x36") K2 20mm  
ANG. INT. BORDO TORO  
45x90 (18"x36") K2 20mm

stone effect | midlake

MIDLAKE ARDESIA  
60x90 (24"x36") K2 20mm

---



# 4

## COLORI/ COLOURS / COULEURS / FARBE / COLORES

MIDLAKE QUARTZGREY V4 **LEED COMPLIANT**



MIDLAKE PORFIDO V4 **LEED COMPLIANT**

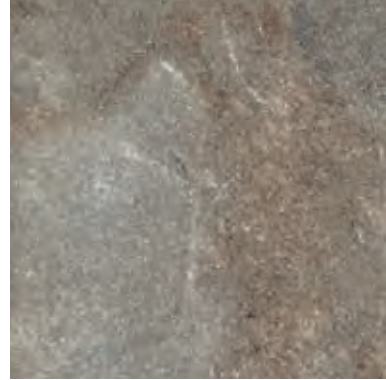

MIDLAKE ARDESIA V4 **LEED COMPLIANT**

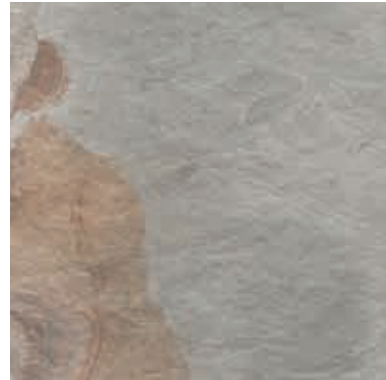

MIDLAKE QUARTZBEIGE V3



# 5

## FORMATI/ SIZES / FORMATS / FORMATE / FORMATOS

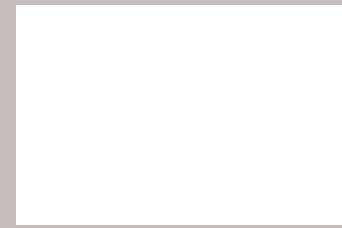

▲ 60x90 (24"x36") RT ⇒ **K2** 20 mm



▲ 22,5x45,3 (9"x18") Not RT 9 mm  
▲ 22,5x45,4 (9"x18") Not RT ⇒ **K2** 20 mm



▲ 22,5x22,5 (9"x9") Not RT 9 mm  
▲ 22,5x22,5 (9"x9") Not RT ⇒ **K2** 20 mm

# 2

## PEZZI SPECIALI/ TRIMS / PIECES SPECIALES / FORMTEILE / PIEZAS ESPECIALES



**BATTISCOPA**  
BULLNOSE / PLINTHE / SOCKEL / RODAPIÉ  
▲ 7,2x45,3 (2,8"x17<sup>13</sup>/<sub>16</sub>") Not RT 9 mm

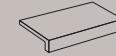

**TERMINALE L MONOLITICO**  
L TERMINAL TEXTURED / TERMINALE ELLE  
STRUCTURÉ / STRUKTURIERTE L STÜCK FLIESE /  
REMATE EN FORMA DE L ESTRUCTURADO  
▲ 30x15x4 (12"x6"x1<sup>9</sup>/<sub>16</sub>") Not RT 9 mm

# 14

## PEZZI SPECIALI K<sub>2</sub>/ TRIMS K<sub>2</sub> / PIECES SPECIALES K<sub>2</sub> / FORMTEILE K<sub>2</sub> / PIEZAS ESPECIALES K<sub>2</sub>

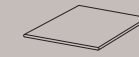

**ANGOLARE BORDO TORO**  
CORNER STEP TREAD / NEZ DE MARCHE ANGULAIRE /  
STUFENPLATTE ECKSTÜCK / ANGULAR CANTO ROMO  
▲ 30x30 (12"x12") RT 20 mm

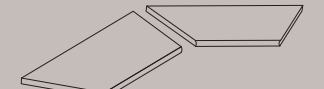

**ANGOLARE INTERNO BORDO TORO**  
INT. CORNER STEP TREAD / ANGLE INT. NEZ DE MARCHE /  
INNENECKTRITTSTUFE / ANG. INT. CANTO ROMO  
▲ 45x90 (18"x36") RT 20 mm  
▲ 30x60 (12"x24") RT 20 mm

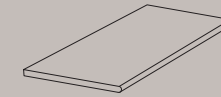

**GRADINO BORDO TORO**  
ROUNDED STEP TREAD / NEZ DE MARCHE ARRONDI /  
GERUNDET STUFENPLATTE / PELDAÑO CANTO ROMO  
▲ 45x90 (18"x36") RT 20 mm  
▲ 30x60 (12"x24") RT 20 mm

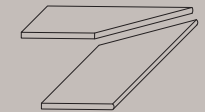

**ANGOLARE ESTERNO BORDO TORO**  
EXT. CORNER STEP TREAD / ANGLE EXT. NEZ DE MARCHE /  
AUSSENECKTRITTSTUFE / ANG. EXT. CANTO ROMO  
▲ 45x90 (18"x36") RT 20 mm  
▲ 30x60 (12"x24") RT 20 mm

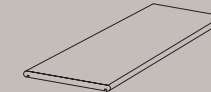

**TOP BORDO TORO**  
TOP STEP TREAD / NEZ DE MARCHE HAUT /  
STUFENPLATTE TOP / TOP CANTO ROMO  
▲ 30x60 (12"x24") RT 20 mm

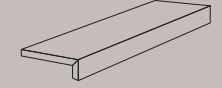

**TERMINALE L**  
GLUED "L" TERMINAL / TERMINAL "L" COLLÉ /  
"L" STÜCK FLIESE GEKLEBT / TERMINAL "L" (PEGADO)  
▲ 90x45x15 (36"x18"x6") RT 20 mm  
▲ 60x33x5 (24"x13"x2") RT 20 mm  
▲ 60x20x5 (24"x8"x2") RT 20 mm

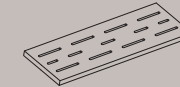

**GRIGLIA**  
GRID / GRIL / GRILL / REJILLA  
▲ 15x60 (6"x24") RT 20 mm

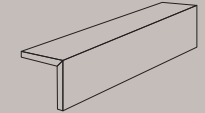

**CORDOLO L**  
GLUED "L" TERMINAL / TERMINAL "L" COLLÉ /  
"L" STÜCK FLIESE GEKLEBT / CANTONERA "L" (PEGADA)  
▲ 60x20x15 (24"x8"x6") RT 20 mm

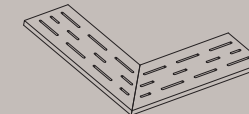

**ANGOLARE GRIGLIA**  
GRID / GRIL / GRILL / ANGULAR REJILLA  
▲ 15x60 (6"x24") RT 20 mm

## FORMATI FORMATS / FORMATS / FORMATE / FORMATOS

	22,5x45,3 9"x18"	22,5x22,5 9"x9"	60x90 24"x36"	22,5x45,4 9"x18"	22,5x22,5 9"x9"
working size	596x897				
	Not RT 9 mm	Not RT 9 mm	RT <b>K2</b> 20 mm	Not RT <b>K2</b> 20 mm	Not RT <b>K2</b> 20 mm
<b>MIDLAKE QUARTZGREY</b>	▲	▲	▲	▲	▲
<b>MIDLAKE PORFIDO</b>	▲	▲	▲	▲	▲
<b>MIDLAKE QUARTZBEIGE</b>	▲	▲	▲	▲	▲
<b>MIDLAKE ARDESIA</b>	▲	▲	▲	▲	▲

▲ Structured R11

▲ Structured R11

# chorus

CHORUS GREY  
60x120 (24"x48") -  
LISTELLO UP 9,7x60 (3<sup>7</sup>/<sub>8</sub>"x24")

---

**5**

COLORI/  
COLOURS  
COULEURS  
FARBE  
COLORES

**11**

FORMATI/  
SIZES  
FORMATS  
FORMATE  
FORMATOS

**3**

SUPERFICI/  
FINISHES  
FINITIONS  
OBERFLÄCHEN  
ACABADOS

**2**

SPESSORI/  
THICKNESS  
ÉPAISSEUR  
STÄRKE  
ESPEJOR

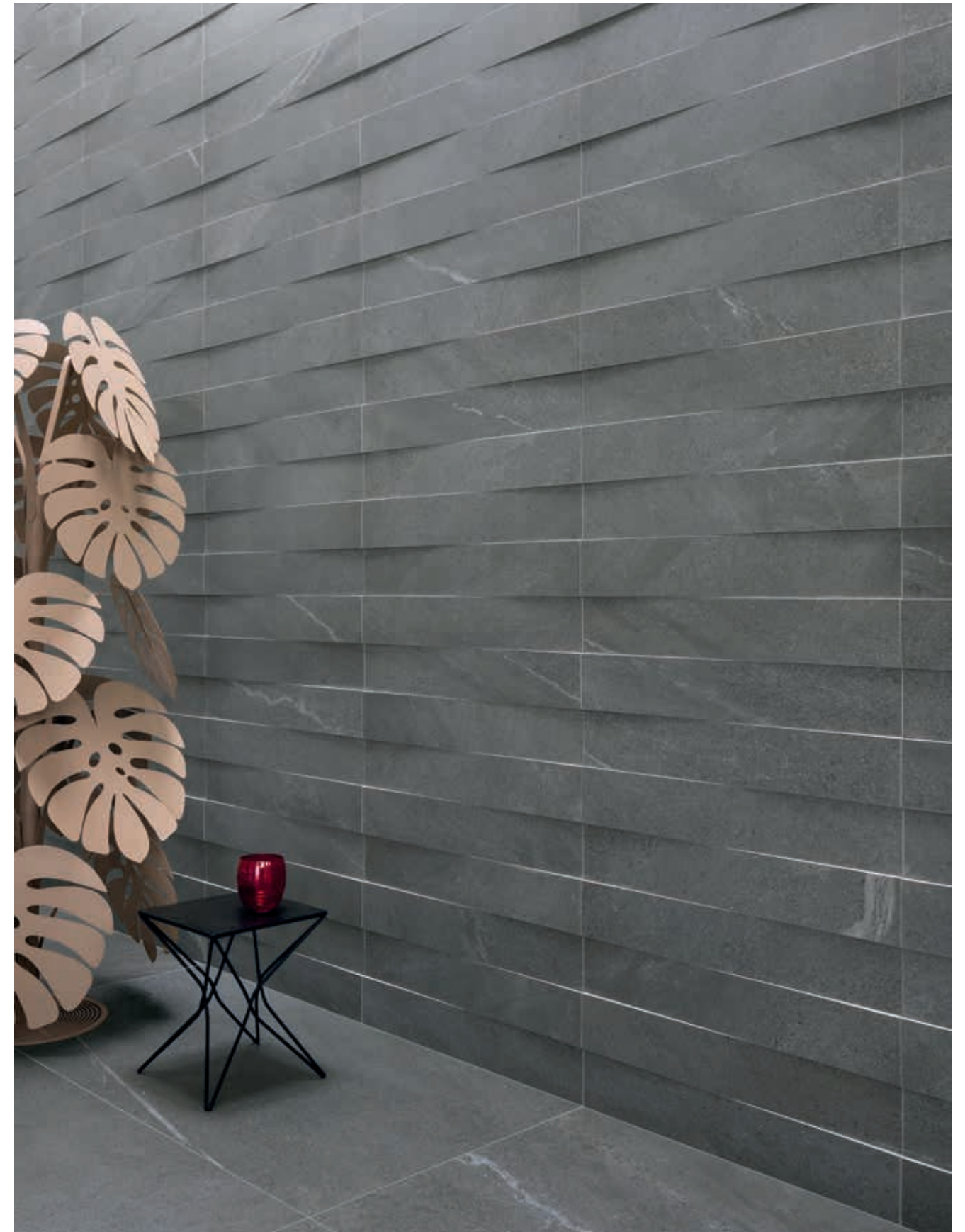

CHORUS SILVER  
60x120 (24"x48") - 30x120 (12"x48")



CHORUS BEIGE  
120x120 (48"x48")

stone effect | chorus





CHORUS TOBACCO  
30x120 (12"x48")

CHORUS WHITE  
120X120 (48"x48")

---

# 5

## COLORI/

COLOURS / COULEURS / FARBE / COLORES

CHORUS TOBACCO V2



CHORUS SILVER V2



CHORUS BEIGE V2



CHORUS GREY V2



CHORUS WHITE V2



# 11

## FORMATI/

SIZES / FORMATS / FORMATE / FORMATOS

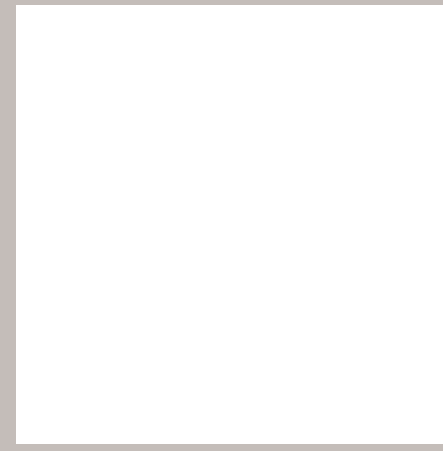

● 120x120 (48"x48") RT 9 mm

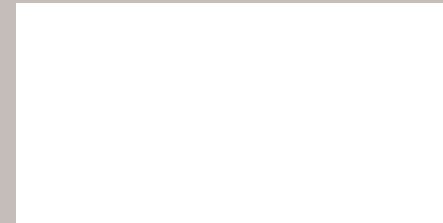

● ● ▲ 60x120 (24"x48") RT 9 mm  
▲ 60x120 (24"x48") RT ≡ K2 20 mm



● 30x120 (12"x48") RT 9 mm

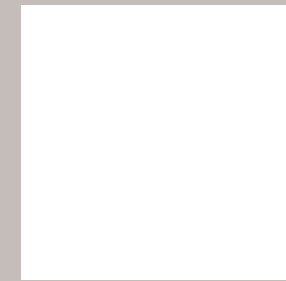

● 75x75 (30"x30") RT 9 mm



● 37,5x75 (15"x30") RT 9 mm

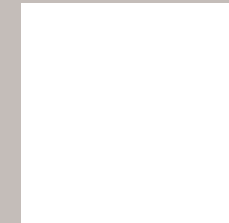

● ● ▲ 60x60 (24"x24") RT 9 mm  
▲ 60x60 (24"x24") RT ≡ K2 20 mm



● ● ▲ 30x60 (12"x24") RT 9 mm  
▲ 30x60 (12"x24") RT ≡ K2 20 mm



● 9,7x60 (3<sup>7</sup>/<sub>8</sub>"x24") RT 9 mm

● Natural R9 | ● Natural R10 | ▲ Grip R11

stone effect | chorus

# 2

## DECORI/

DECORS / PIECES SPECIALES / FORMTEILE /  
PIEZAS ESPECIALES

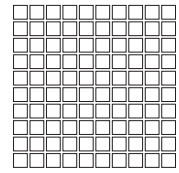

**MOSAICO ● 30x30 (12"x12") RT 9mm**  
(TESSERE: 2,8x2,8 - 1 1/8"x1 1/8")



CHORUS TOBACCO



CHORUS SILVER



CHORUS GREY



CHORUS WHITE



CHORUS BEIGE



**LISTELLO UP ● 9,7x60 (3 7/8"x24") RT 9 mm**



CHORUS TOBACCO



CHORUS SILVER



CHORUS GREY



CHORUS WHITE



CHORUS BEIGE

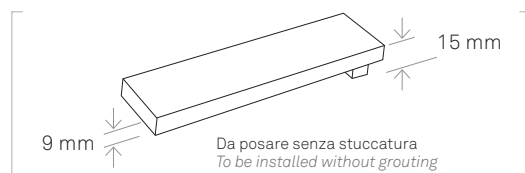

# 6

## PEZZI SPECIALI/

TRIMS / PIECES SPECIALES / FORMTEILE /  
PIEZAS ESPECIALES



**BATTISCOPA**  
BULLNOSE / PLINTHE / SOCKEL / RODAPIÉ  
● 7,2x75 (2.8"x30") RT 9 mm  
● 7,2x60 (2.8"x24") RT 9 mm

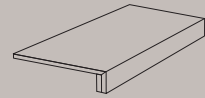

**SCALINO INCOLLATO**  
GLUED STEP TREAD / NEZ DE MARCHE COLLÉ / GEKLEBTE STUFENPLATTE / PELDAÑO CON PERFIL PEGADO  
● 33x60 (13"x24") RT 9 mm

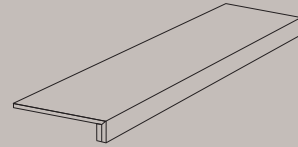

**SCALINO INCOLLATO**  
GLUED STEP TREAD / NEZ DE MARCHE COLLÉ / GEKLEBTE STUFENPLATTE / PELDAÑO CON PERFIL PEGADO  
● 33x120 (13"x48") RT 9 mm



**SCALINO ANGOLARE INCOLLATO**  
GLUED CORNER STEP TREAD / CARREAU DE MARCHE COLLÉ PIÈCE ANGULAIRE / GEKLEBTE STUFENPLATTE ECKSTÜCK / PELDAÑO ESQUINA CON PERFIL PEGADO  
● 33x33 (13"x13") RT 9 mm

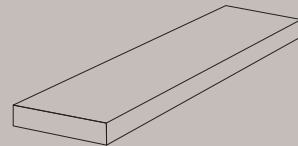

**SCALINO ANGOLARE INCOLLATO**  
GLUED CORNER STEP TREAD / CARREAU DE MARCHE COLLÉ PIÈCE ANGULAIRE / GEKLEBTE STUFENPLATTE ECKSTÜCK / PELDAÑO ESQUINA CON PERFIL PEGADO  
● 33x120 (13"x48") RT 9 mm

# 17

## PEZZI SPECIALI K<sub>2</sub>/

TRIMS K<sub>2</sub> / PIECES SPECIALES K<sub>2</sub> / FORMTEILE K<sub>2</sub> /  
PIEZAS ESPECIALES K<sub>2</sub>

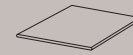

**ANGOLARE BORDO TORO**  
CORNER STEP TREAD / NEZ DE MARCHE ANGULAIRE / STUFENPLATTE ECKSTÜCK / ANGULAR CANTO ROMO  
▲ 30x30 (12"x12") RT 20 mm

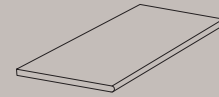

**GRADINO BORDO TORO**  
ROUNDED STEP TREAD / NEZ DE MARCHE ARRONDI / GERUNDET STUFENPLATTE / PELDAÑO CANTO ROMO  
▲ 60x120 (24"x48") RT 20 mm  
▲ 30x120 (12"x48") RT 20 mm  
▲ 30x60 (12"x24") RT 20 mm

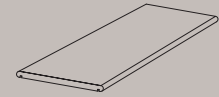

**TOP BORDO TORO**  
TOP STEP TREAD / NEZ DE MARCHE HAUT / STUFENPLATTE TOP / TOP CANTO ROMO  
▲ 30x60 (12"x24") RT 20 mm

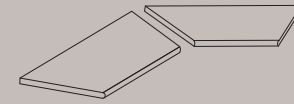

**ANGOLARE INTERNO BORDO TORO**  
INT. CORNER STEP TREAD / ANGLE INT. NEZ DE MARCHE / INNENECKTRITTSTUFE / ANG. INT. CANTO ROMO  
▲ 60x120 (24"x48") RT 20 mm  
▲ 30x120 (12"x48") RT 20 mm  
▲ 30x60 (12"x24") RT 20 mm

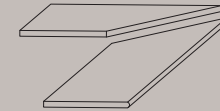

**ANGOLARE ESTERNO BORDO TORO**  
EXT. CORNER STEP TREAD / ANGLE EXT. NEZ DE MARCHE / AUSSENECKTRITTSTUFE / ANG. EXT. CANTO ROMO  
▲ 60x120 (24"x48") RT 20 mm  
▲ 30x120 (12"x48") RT 20 mm  
▲ 30x60 (12"x24") RT 20 mm

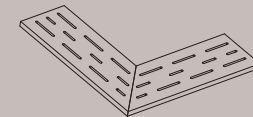

**ANGOLARE GRIGLIA**  
GRID / GRIL / GRILL / ANGULAR REJILLA  
▲ 15x60 (6"x24") RT 20 mm

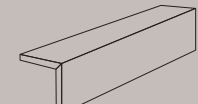

**CORDOLO L**  
GLUED "L" TERMINAL / TERMINAL "L" COLLÉ / "L" STÜCK FLIESE GEKLEBT / TERMINAL "L" (PEGADO)  
▲ 60x20x15 (24"x8"x6") RT 20 mm

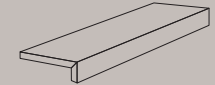

**TERMINALE L**  
GLUED "L" TERMINAL / TERMINAL "L" COLLÉ / "L" STÜCK FLIESE GEKLEBT / TERMINAL "L" (PEGADO)  
▲ 120x45x15 (48"x18"x6") RT 20 mm  
▲ 60x20x5 (24"x8"x2") RT 20 mm  
▲ 60x33x5 (13"x24"x2") RT 20 mm

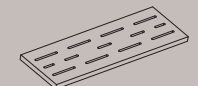

**GRIGLIA**  
GRID / GRIL / GRILL / REJILLA  
▲ 15x60 (6"x24") RT 20 mm

## FORMATI

SIZES / FORMATS / FORMATE / FORMATOS

	120x120 (119,5x119,5)* 48"x48"	60x120 24"x48"	30x120 12"x48"	75x75 30"x30"	37,5x75 15"x30"	60x60 24"x24"	30x60 12"x24"	9,7x60 3 7/8"x24"	60x120 24"x48"	60x60 24"x24"	30x60 12"x24"
working size	1194x1194	596x1195	397x1195	748x748	373x748	596x596	297x596	97x596	596x1195	596x596	297x596
	RT	RT	RT	RT	RT	RT	RT	RT	RT	RT	RT
	9 mm	9 mm	9 mm	9 mm	9 mm	9 mm	9 mm	9 mm	K2 20 mm	K2 20 mm	K2 20 mm
CHORUS TOBACCO		●●▲	●	●	●	●●▲	●●▲	●			
CHORUS SILVER	●	●●▲	●	●	●	●●▲	●●▲	●	▲	▲	▲
CHORUS BEIGE	●	●●▲	●	●	●	●●▲	●●▲	●	▲	▲	▲
CHORUS GREY		●●▲	●	●	●	●●▲	●●▲	●			
CHORUS WHITE	●	●●▲	●	●	●	●●▲	●●▲	●	▲	▲	▲

\*Formato nominale / Nominal size / Format nominal / Nennformat / Formato nominal

● Natural R9 | ● Natural R10 | ▲ Grip R11

PIETRA DI FAEDIS  
60x60 (24"x24") - 30x60 (12"x24")

# percorsi extra

**4**

COLORI/  
COLOURS  
COULEURS  
FARBE  
COLORES

**11**

FORMATI/  
SIZES  
FORMATS  
FORMATE  
FORMATOS

**3**

SUPERFICI/  
FINISHES  
FINITIONS  
OBERFLÄCHEN  
ACABADOS

**3**

SPESSORI/  
THICKNESS  
ÉPAISSEUR  
STÄRKE  
ESPESOR



stone effect | percorsi extra

PIETRA DI COMBE  
60x60 (24"x24") - 30x60 (12"x24")



PIETRA DI VALS  
60x60 (24"x24")

stone effect | percorsi extra

PIETRA DI BARGE  
60x60 (24"x24")

---



stone effect | percorsi extra

# 4

**COLORI/**  
COLOURS / COULEURS / FARBE / COLORES

PIETRA DI VALS **V3**

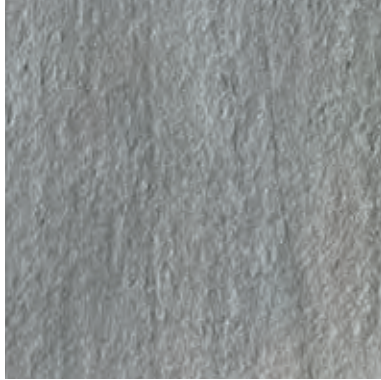

PIETRA DI COMBE **V2**



LEED  
COMPLIANT

PIETRA DI BARGE **V3**



PIETRA DI FAEDIS **V3**

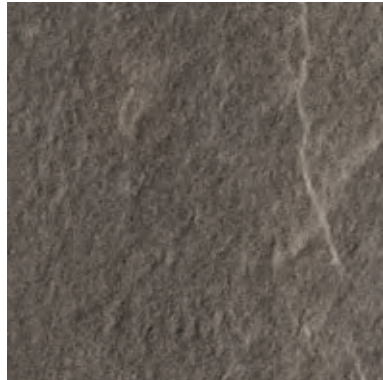

LEED  
COMPLIANT

# 11

**FORMATI/**  
SIZES / FORMATS / FORMATE / FORMATOS



▲ 120x240 (48"x96") ➔ K2 20 mm



▲ 120x120 (48"x48") ➔ K2 20 mm

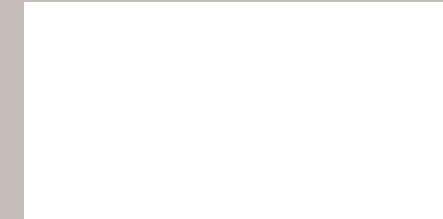

● ■ ▲ 60x120 (24"x48") RT 9 mm  
▲ 60x120 (24"x48") ➔ K2 20 mm



▲ 30x120 (12"x48") ➔ K2 20 mm

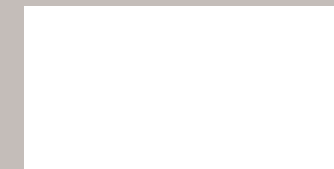

▲ 45x90 (18"x36") ➔ K2 20 mm

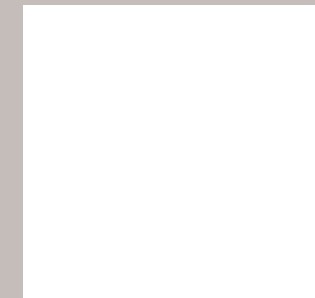

▲ 80x80 (32"x32") RT ➔ K2 20 mm

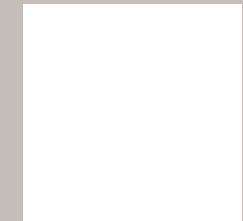

● ■ ▲ 60x60 (24"x24") RT 9 mm  
▲ 60x60 (24"x24") ➔ K2 20 mm  
▲ 60x60 (24"x24") ➔ K3 30 mm



● ■ ▲ 30x60 (12"x24") RT 9 mm

# 3

## DECORI/

DECORS / PIECES SPECIALES / FORMTEILE /  
PIEZAS ESPECIALES

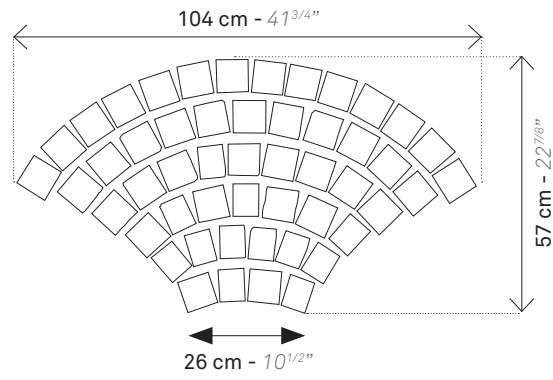

**CODA DI PAVONE**  
▲ 104x57 (41<sup>3/4</sup>"x22<sup>7/8</sup>") RT 9 mm  
(TOZZETTI: 6x7,5 - 21/2"x3" - 7,5x7,5 - 3"x3")



PIETRA DI VALS



PIETRA DI COMBE



PIETRA DI BARGE

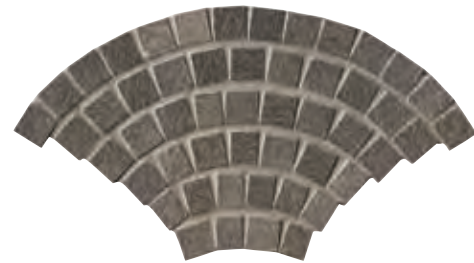

PIETRA DI FAEDIS

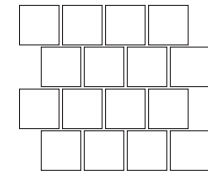

**MOSAICO BURATTATO**  
▲ 31x31 (12<sup>1/2</sup>"x12<sup>1/2</sup>") RT 9 mm  
(TOZZETTO: 7,5x7,5 - 3"x3")



PIETRA DI VALS



PIETRA DI COMBE



PIETRA DI BARGE



PIETRA DI FAEDIS

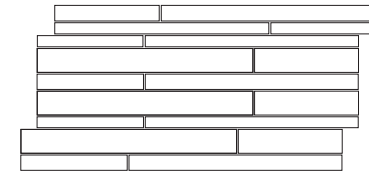

**MOSAICO MULTISPESSORE**  
▲ 30x60 (12"x24") RT 9 mm



PIETRA DI VALS



PIETRA DI COMBE



PIETRA DI BARGE



PIETRA DI FAEDIS

Da posare senza stuccatura / To be installed  
without grouting / À poser sans mastic / Ohne  
Ausfugung zu verlegen / Colocación sin masilla



# 9

## PEZZI SPECIALI/

TRIMS / PIECES SPECIALES / FORMTEILE /  
PIEZAS ESPECIALES



### BATTISCOPA

BULLNOSE / PLINTHE / SOCKEL / RODAPIÉ

●▲ 7,2x60 (2,8"x24") RT 9 mm

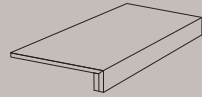

### SCALINO INCOLLATO

GLUED STEP TREAD / NEZ DE MARCHE COLLÉ /  
GEKLEBTE STUFENPLATTE / PELDAÑO CON PERFIL PEGADO

●■▲ 33x60 (13"x24") RT 9 mm

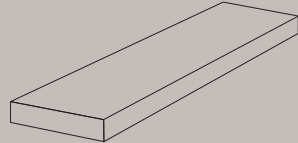

### SCALINO ANGOLARE INCOLLATO

GLUED CORNER STEP TREAD / CARREAU DE MARCHE COLLÉ /  
PIÈCE ANGULAIRE / GEKLEBTE STUFENPLATTE ECKSTÜCK /  
PELDAÑO ESQUINA CON PERFIL PEGADO

●■▲ 33x120 (13"x48") RT 9 mm

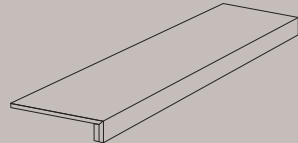

### SCALINO INCOLLATO

GLUED STEP TREAD / NEZ DE MARCHE COLLÉ /  
GEKLEBTE STUFENPLATTE / PELDAÑO CON PERFIL PEGADO

●■▲ 33x120 (13"x48") RT 9 mm



### SCALINO ANGOLARE INCOLLATO

GLUED CORNER STEP TREAD / CARREAU DE MARCHE COLLÉ PIÈCE ANGULAIRE /  
GEKLEBTE STUFENPLATTE ECKSTÜCK / PELDAÑO ESQUINA CON PERFIL PEGADO

●■▲ 33x33 (13"x13") RT 9 mm

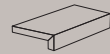

### TERMINALE L INCOLLATO

GLUED L TERMINAL / TERMINALE ELLE COLLÉ / L STÜCK  
FLIESE GEKLEBT / REMATE EN FORMA DE L PEGADO

●■▲ 30x4x15 (12"x1<sup>3/4</sup>"x6") RT 9 mm

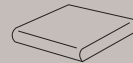

### SCALINO ANGOLARE MONOLITICO

CORNER STEP TREAD TEXTURED / CARREAU DE MARCHE PIECE  
ANGULAIRE STRUCTURÉ / STRUKTURIERTE STUFENPLATTE ECKSTÜCK /  
PELDAÑO ESQUINA ESTRUCTURADO

▲ 33x33 (13"x13") RT 10 mm



### SCALINO MONOLITICO

STEP TREAD TEXTURED / NEZ DE MARCHE STRUCTURÉ /  
STRUKTURIERTE STUFENPLATTE / PELDAÑO ESTRUCTURADO

▲ 30x33 (12"x13") RT 10 mm

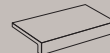

### TERMINALE L MONOLITICO

L TERMINAL TEXTURED / TERMINALE ELLE STRUCTURÉ /  
STRUKTURIERTE L STÜCK FLIESE / REMATE EN FORMA DE L ESTRUCTURADO

▲ 30x3,8x16,5 (12"x1<sup>1/2</sup>"x6<sup>1/2</sup>") Not RT 10 mm

# 31

## PEZZI SPECIALI K<sub>2</sub>/

TRIMS K<sub>2</sub> / PIECES SPECIALES K<sub>2</sub> / FORMTEILE K<sub>2</sub> /  
PIEZAS ESPECIALES K<sub>2</sub>

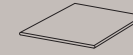

### ANGOLARE BORDO TORO

CORNER STEP TREAD / NEZ DE MARCHE ANGULAIRE /  
STUFENPLATTE ECKSTÜCK / ANGULAR CANTO ROMO

▲ 40x40 (16"x16") RT 20 mm

▲ 30x30 (12"x12") RT 20 mm

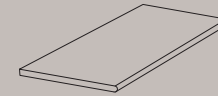

### GRADINO BORDO TORO

ROUNDED STEP TREAD / NEZ DE MARCHE ARRONDI /  
GERUNDET STUFENPLATTE / PELDAÑO CANTO ROMO

▲ 60x120 (24"x48") RT 20 mm

▲ 30x120 (12"x48") RT 20 mm

▲ 45x90 (18"x36") RT 20 mm

▲ 40x80 (16"x32") RT 20 mm

▲ 30x60 (12"x24") RT 20 mm

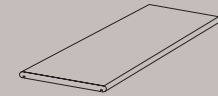

### TOP BORDO TORO

TOP STEP TREAD / NEZ DE MARCHE HAUT /  
STUFENPLATTE TOP / TOP CANTO ROMO

▲ 30x60 (12"x24") RT 20 mm

▲ 40x80 (16"x32") RT 20 mm

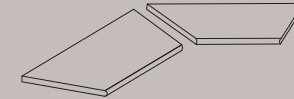

### ANGOLARE INTERNO BORDO TORO

INT. CORNER STEP TREAD / ANGLE INT. NEZ DE MARCHE /  
INNENECKTRITTSTUFE / ANG. INT. CANTO ROMO

▲ 60x120 (24"x48") RT 20 mm

▲ 30x120 (12"x48") RT 20 mm

▲ 45x90 (18"x36") RT 20 mm

▲ 40x80 (16"x32") RT 20 mm

▲ 30x60 (12"x24") RT 20 mm

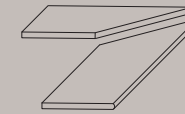

### ANGOLARE ESTERNO BORDO TORO

EXT. CORNER STEP TREAD / ANGLE EXT. NEZ DE MARCHE /  
AUSSENECKTRITTSTUFE / ANG. EXT. CANTO ROMO

▲ 60x120 (24"x48") RT 20 mm

▲ 30x120 (12"x48") RT 20 mm

▲ 45x90 (18"x36") RT 20 mm

▲ 40x80 (16"x32") RT 20 mm

▲ 30x60 (12"x24") RT 20 mm

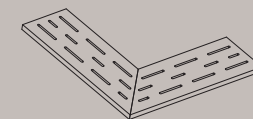

### ANGOLARE GRIGLIA

GRID / GRIL / GRILL / ANGULAR REJILLA

▲ 20x80 (8"x32") RT 20 mm

▲ 15x60 (6"x24") RT 20 mm

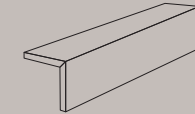

### CORDOLO L

GLUED "L" TERMINAL / TERMINAL "L" COLLÉ /  
"L" STÜCK FLIESE GEKLEBT / CANTONERA "L" (PEGADA)

▲ 80x20x20 (32"x8"x8") RT 20 mm

▲ 60x20x15 (24"x8"x6") RT 20 mm

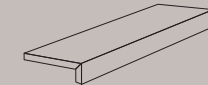

### TERMINALE L

GLUED "L" TERMINAL / TERMINAL "L" COLLÉ /  
"L" STÜCK FLIESE GEKLEBT / TERMINAL "L" (PEGADO)

▲ 120x45x15 (48"x18"x6") RT 20 mm

▲ 90x45x15 (36"x18"x6") RT 20 mm

▲ 80x33x5 (32"x13"x2") RT 20 mm

▲ 80x20x5 (32"x8"x2") RT 20 mm

▲ 60x20x5 (24"x8"x2") RT 20 mm

▲ 60x33x5 (13"x24"x2") RT 20 mm

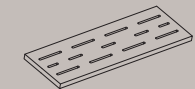

### GRIGLIA

GRID / GRIL / GRILL / REJILLA

▲ 20x80 (8"x32") RT 20 mm

▲ 15x60 (6"x24") RT 20 mm

## FORMATI

FORMATS / FORMATS / FORMATE / FORMATOS

	60x120 24"x48"	60x60 24"x24"	30x60 12"x24"	120x240 (119,5x239)* 48"x96"	120x120 (119,5x119,5)* 48"x48"	60x120 24"x48"	30x120 12"x48"	45x90 18"x36"	80x80 32"x32"	60x60 24"x24"	60x60 24"x24"
working size	596x1195	596x596	297x596	1194x2390	1194x1194	596x1195	297x1195	446x895	795x795	596x596	596x596
	RT	RT	RT	RT	RT	RT	RT	RT	RT	RT	RT
	9 mm	9 mm	9 mm	K2 20 mm	K2 20 mm	K2 20 mm	K2 20 mm	K2 20 mm	K2 20 mm	K2 20 mm	K3 30 mm
P. DI VALS	●■▲	●■▲	●■▲	▲	▲	▲	▲	▲	▲	▲	▲
P. DI BARGE	●■▲	●■▲	●■▲		▲	▲	▲	▲	▲	▲	▲
P. DI FAEDIS	●■▲	●■▲	●■▲					▲		▲	
P. DI COMBE	●■▲	●■▲	●■▲					▲		▲	

\*Formato nominale / Nominal size / Format nominal / Nennformat / Formato nominal

● Natural R9 | ■ Structured R10 | ▲ Structured R11

PERCORSI QUARTZ WHITE  
30x60 (12"x24")

# percorsi quartz

**4**

COLORI/  
COLOURS  
COULEURS  
FARBE  
COLORES

**3**

FORMATI/  
SIZES  
FORMATS  
FORMATE  
FORMATOS

**2**

SUPERFICI/  
FINISHES  
FINITIONS  
OBERFLÄCHEN  
ACABADOS

**2**

SPESSORI/  
THICKNESS  
ÉPAISSEUR  
STÄRKE  
ESPESOR



stone effect | percorsi quartz



PERCORSI QUARTZ SAND  
60x60 (24"x24") - 30x60 (12"x24")

---



PERCORSI QUARTZ GREY  
30x60 (12"x24")

---

# 4

## COLORI/

COLOURS / COULEURS / FARBE / COLORES

PERCORSI QUARTZ WHITE V2



PERCORSI QUARTZ SAND V2



PERCORSI QUARTZ BLACK V2

LEED COMPLIANT



PERCORSI QUARTZ GREY V2

LEED COMPLIANT



# 3

## FORMATI/

SIZES / FORMATS / FORMATE / FORMATOS



- ▲ 60x60 (24"x24") RT 9 mm
- ▲ 60x60 (24"x24") RT ➔ K2 20 mm



- ▲ 30x60 (12"x24") RT 9 mm

# 7

## PEZZI SPECIALI/

TRIMS / PIECES SPECIALES / FORMTEILE / PIEZAS ESPECIALES



- BATTISCOPA**  
BULLNOSE / PLINTHE / SOCKEL / RODAPIÉ
- ▲ 7,2x60 (2,8"x24") RT 9 mm

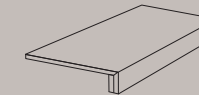

- SCALINO INCOLLATO**  
GLUED STEP TREAD / NEZ DE MARCHE COLLÉ / GEKLEBTE STUFENPLATTE / PELDAÑO CON PERFIL PEGADO
- ▲ 33x60 (13"x24") RT 9 mm

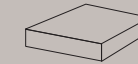

- SCALINO ANGOLARE INCOLLATO**  
GLUED CORNER STEP TREAD / CARREAU DE MARCHE COLLÉ / PIÈCE ANGULAIRE / GEKLEBTE STUFENPLATTE ECKSTÜCK / PELDAÑO ESQUINA CON PERFIL PEGADO
- ▲ 33x33 (13"x13") RT 9 mm



- TERMINALE L INCOLLATO**  
GLUED L TERMINAL / TERMINALE ELLE COLLÉ / L STÜCK / FLIESE GEKLEBT / REMATE EN FORMA DE L PEGADO
- ▲ 30x4x15 (12"x13/4"x6") RT 9 mm



- SCALINO MONOLITICO**  
STEP TREAD TEXTURED / NEZ DE MARCHE STRUCTURÉ / STRUKTURIERTE STUFENPLATTE / PELDAÑO ESTRUCTURADO
- ▲ 30x33 (12"x13") RT 10 mm

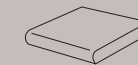

- SCALINO ANGOLARE MONOLITICO**  
CORNER STEP TREAD TEXTURED / CARREAU DE MARCHE PIECE ANGULAIRE STRUCTURÉ / STRUKTURIERTE STUFENPLATTE ECKSTÜCK / PELDAÑO ESQUINA ESTRUCTURADO
- ▲ 33x33 (13"x13") RT 10 mm



- TERMINALE L MONOLITICO**  
L TERMINAL TEXTURED / TERMINALE ELLE STRUCTURÉ / STRUKTURIERTE L STÜCK FLIESE / REMATE EN FORMA DE L ESTRUCTURADO
- ▲ 30x3,8x16,5 (12"x11/2"x61/2") Not RT 10 mm

● Natural R9 | ▲ Structured R11

stone effect | percorsi quartz

# 2

## DECORI/

DECORS / PIECES SPECIALES / FORMTEILE /  
PIEZAS ESPECIALES

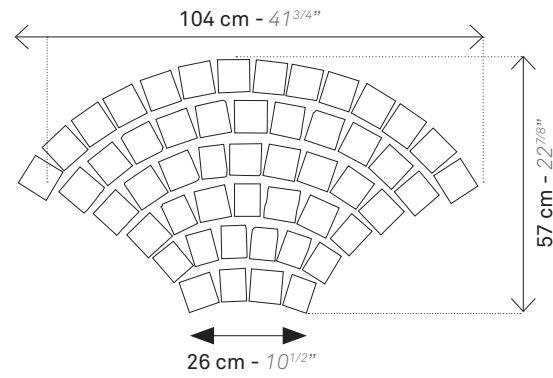

**CODA DI PAVONE**  
▲ 104x57 (41<sup>3/4</sup> x 22<sup>7/8</sup>) RT 9 mm  
(TOZZETTI: 6x7,5 - 21/2"x3" - 7,5x7,5 - 3"x3")



PERCORSI QUARTZ WHITE



PERCORSI QUARTZ SAND

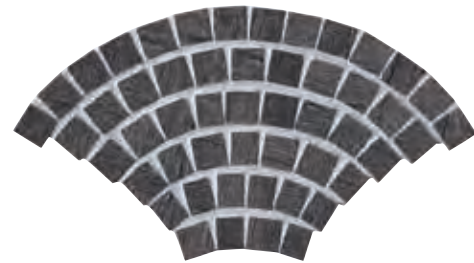

PERCORSI QUARTZ SAND



PERCORSI QUARTZ GREY

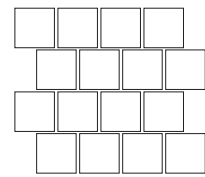

**MOSAICO BURATTATO**  
▲ 31x31 (12<sup>1/2</sup> x 12<sup>1/2</sup>) RT 9 mm  
(TOZZETTO: 7,5x7,5 - 3"x3")



PERCORSI QUARTZ WHITE



PERCORSI QUARTZ SAND



PERCORSI QUARTZ BLACK



PERCORSI QUARTZ GREY

# 10

## PEZZI SPECIALI K<sub>2</sub>/

TRIMS K<sub>2</sub> / PIECES SPECIALES K<sub>2</sub> / FORMTEILE K<sub>2</sub> /  
PIEZAS ESPECIALES K<sub>2</sub>

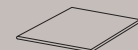

**ANGOLARE BORDO TORO**  
CORNER STEP TREAD / NEZ DE MARCHE ANGULAIRE /  
STUFENPLATTE ECKSTÜCK / ANGULAR CANTO ROMO  
▲ 30x30 (12"x12") RT 20 mm

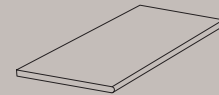

**GRADINO BORDO TORO**  
ROUNDED STEP TREAD / NEZ DE MARCHE ARRONDI /  
GERUNDET STUFENPLATTE / PELDAÑO CANTO ROMO  
▲ 30x60 (12"x24") RT 20 mm

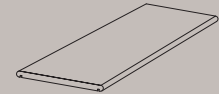

**TOP BORDO TORO**  
TOP STEP TREAD / NEZ DE MARCHE HAUT /  
STUFENPLATTE TOP / TOP CANTO ROMO  
▲ 30x60 (12"x24") RT 20 mm

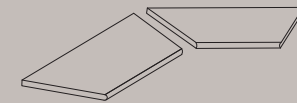

**ANGOLARE INTERNO BORDO TORO**  
INT. CORNER STEP TREAD / ANGLE INT. NEZ DE MARCHE /  
INNENECKTRITTSTUFE / ANG. INT. CANTO ROMO  
▲ 30x60 (12"x24") RT 20 mm

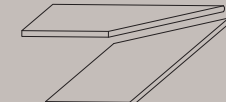

**ANGOLARE ESTERNO BORDO TORO**  
EXT. CORNER STEP TREAD / ANGLE EXT. NEZ DE MARCHE /  
AUSSENECKTRITTSTUFE / ANG. EXT. CANTO ROMO  
▲ 30x60 (12"x24") RT 20 mm

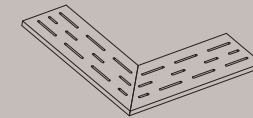

**ANGOLARE GRIGLIA**  
GRID / GRIL / GRILL / ANGULAR REJILLA  
▲ 15x60 (6"x24") RT 20 mm

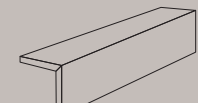

**CORDOLO L**  
GLUED "L" TERMINAL / TERMINAL "L" COLLÉ /  
"L" STÜCK FLIESE GEKLEBT / CANTONERA "L" (PEGADA)  
▲ 60x20x15 (24"x8"x6") RT 20 mm

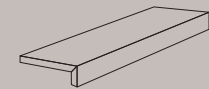

**TERMINALE L**  
GLUED "L" TERMINAL / TERMINAL "L" COLLÉ /  
"L" STÜCK FLIESE GEKLEBT / TERMINAL "L" (PEGADO)  
▲ 60x33x5 (24"x13"x2") RT 20 mm  
▲ 60x20x5 (24"x8"x2") RT 20 mm

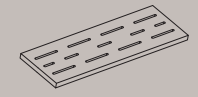

**GRIGLIA**  
GRID / GRIL / GRILL / REJILLA  
▲ 15x60 (6"x24") RT 20 mm

### FORMATI

FORMATS / FORMATS / FORMATE / FORMATOS

	60x60 24"x24"	30x60 12"x24"	60x60 24"x24"
working size	596x596	297x596	596x596
	RT	RT	RT
	9 mm	9 mm	K <sub>2</sub> 20 mm
PERCORSI QUARTZ WHITE	●▲	●▲	▲
PERCORSI QUARTZ SAND	●▲	●▲	
PERCORSI QUARTZ BLACK	●▲	●▲	▲
PERCORSI QUARTZ GREY	●▲	●▲	

● Natural R9 | ▲ Structured R11

# percorsi smart

PIETRA DI LAVIS  
60x60 (24"x24") - 30x60 (12"x24")

**3**

COLORI/  
COLOURS  
COULEURS  
FARBE  
COLORES

**9**

FORMATI/  
SIZES  
FORMATS  
FORMATE  
FORMATOS

**2**

SUPERFICI/  
FINISHES  
FINITIONS  
OBERFLÄCHEN  
ACABADOS

**3**

SPESSORI/  
THICKNESS  
ÉPAISSEUR  
STÄRKE  
ESPESOR

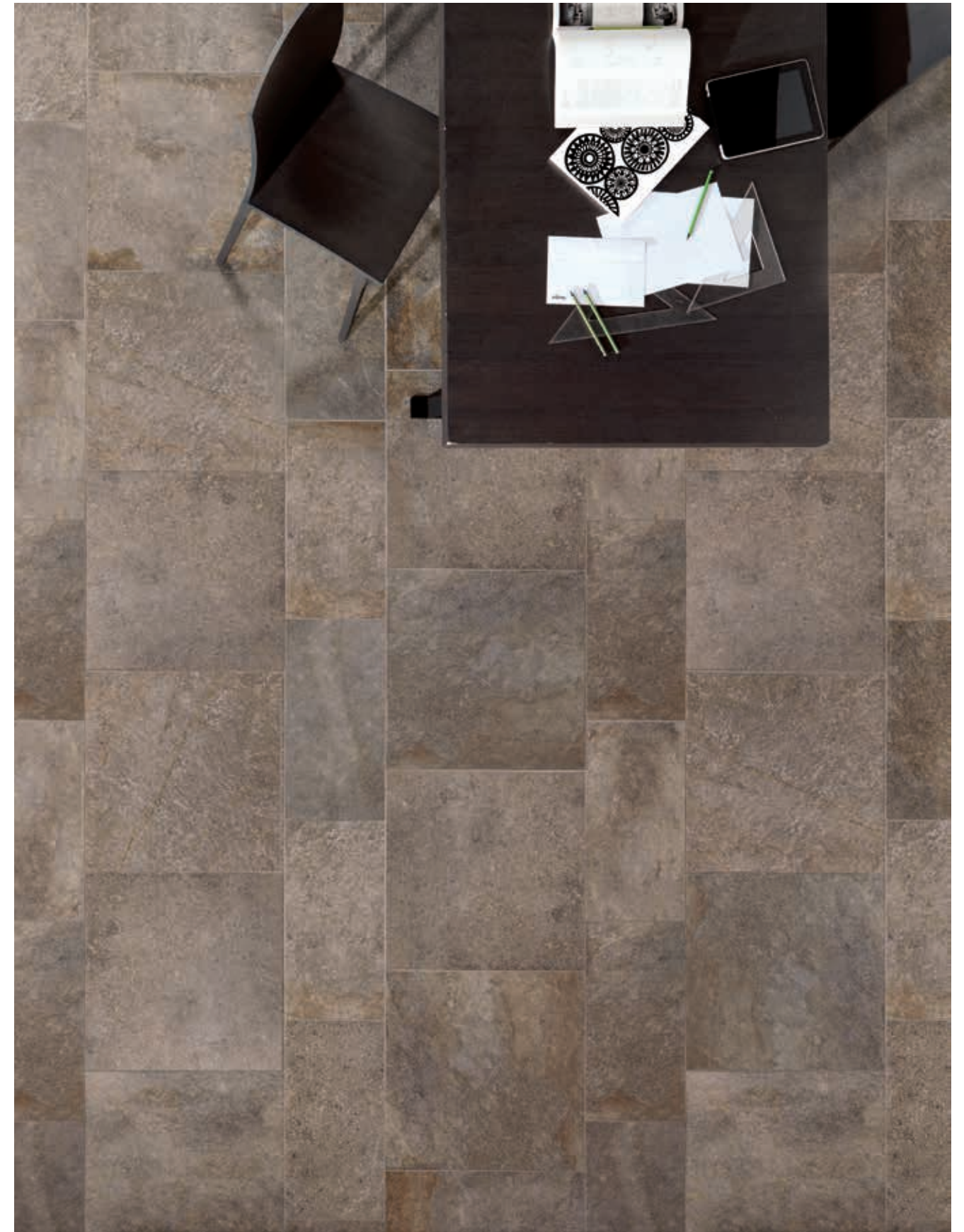

PIETRA DI BRESSA  
60x60 (24"x24") - 30x60 (12"x24")



PIETRA DI BAGNOLO  
120x120 (48"x48") K2 20mm

stone effect | percorsi smart

# 3

## COLORI/

COLOURS / COULEURS / FARBE / COLORES

PIETRA DI BRESSA **V3**



PIETRA DI BAGNOLO **V2**



PIETRA DI LAVIS **V4**

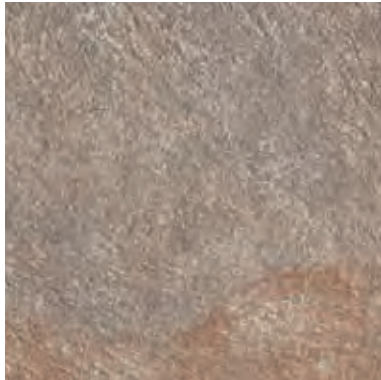

# 9

## FORMATI/

SIZES / FORMATS / FORMATE / FORMATOS

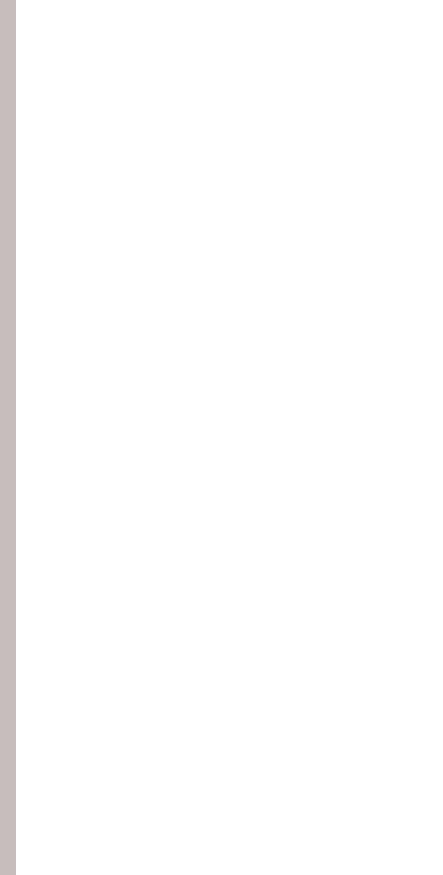

▲ 120x240 (48"x96") RT **K2** 20 mm



▲ 120x120 (48"x48") RT **K2** 20 mm



▲ 45x90 (18"x36") RT **K2** 20 mm

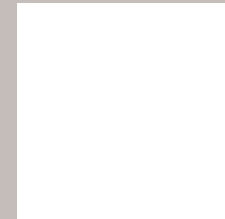

- ▲ 60x60 (24"x24") RT 9 mm
- ▲ 60x60 (24"x24") RT **K2** 20 mm
- ▲ 60x60 (24"x24") RT **K3** 30 mm



●▲ 30x60 (12"x24") RT 9mm



▲ 30x240 (12"x96") RT **K2** 20 mm



▲ 15x30 (6"x12") Not RT 9 mm

stone effect | percorsi smart



# 1

## DECORI/

DECORS / PIECES SPECIALES / FORMTEILE /  
PIEZAS ESPECIALES

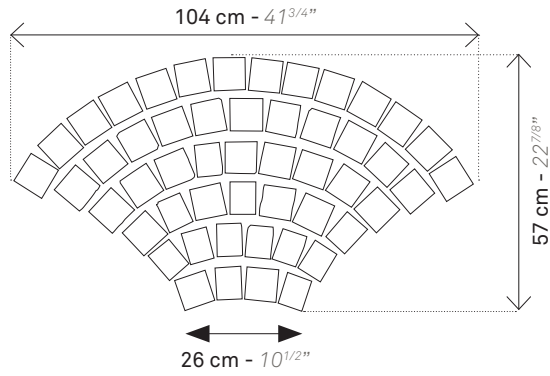

**CODA DI PAVONE**  
▲ 104x57 (41<sup>3/4</sup>”x22<sup>7/8</sup>”) RT 9 mm  
(TOZZETTI: 6x7,5 - 21/2”x3” - 7,5x7,5 - 3”x3”)



PIETRA DI BRESSA



PIETRA DI BAGNOLO



PIETRA DI LAVIS

# 5

## PEZZI SPECIALI/

TRIMS / PIECES SPECIALES / FORMTEILE /  
PIEZAS ESPECIALES



**BATTISCOPIA**  
BULLNOSE / PLINTHE / SOCKEL / RODAPIÉ  
●▲ 7,2x60 (2,8”x24”) RT 9 mm

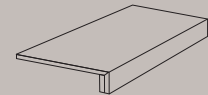

**SCALINO INCOLLATO**  
GLUED STEP TREAD / NEZ DE MARCHE COLLÉ / GEKLEBTE STUFENPLATTE / PELDAÑO CON PERFIL PEGADO  
●▲ 33x60 (13”x24”) RT 9 mm



**SCALINO ANGOLARE INCOLLATO**  
GLUED CORNER STEP TREAD / CARREAU DE MARCHE COLLÉ / PIÈCE ANGULAIRE / GEKLEBTE STUFENPLATTE ECKSTÜCK / PELDAÑO ESQUINA CON PERFIL PEGADO  
●▲ 33x33 (13”x13”) RT 9 mm



**TERMINALE L INCOLLATO**  
GLUED L TERMINAL / TERMINALE ELLE COLLÉ / L STÜCK FLIESE GEKLEBT / REMATE EN FORMA DE L PEGADO  
●▲ 30x4x15 (12”x1<sup>3/4</sup>”x6”) RT 9 mm

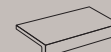

**TERMINALE L MONOLITICO**  
L TERMINAL TEXTURED / TERMINALE ELLE STRUCTURÉ / STRUKTURIERTE L STÜCK FLIESE / REMATE EN FORMA DE L ESTRUCTURADO  
▲ 30x3,8x16,5 (12”x1<sup>1/2</sup>”x6<sup>1/2</sup>”) Not RT 10 mm

# 14

## PEZZI SPECIALI K<sub>2</sub>/

TRIMS K<sub>2</sub> / PIECES SPECIALES K<sub>2</sub> / FORMTEILE K<sub>2</sub> /  
PIEZAS ESPECIALES K<sub>2</sub>

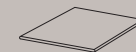

**ANGOLARE BORDO TORO**  
CORNER STEP TREAD / NEZ DE MARCHE ANGULAIRE / STUFENPLATTE ECKSTÜCK / ANGULAR CANTO ROMO  
▲ 30x30 (12”x12”) RT 20 mm

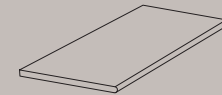

**GRADINO BORDO TORO**  
ROUNDED STEP TREAD / NEZ DE MARCHE ARRONDI / GERUNDET STUFENPLATTE / PELDAÑO CANTO ROMO  
▲ 45x90 (18”x36”) RT 20 mm  
▲ 30x60 (12”x24”) RT 20 mm

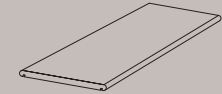

**TOP BORDO TORO**  
TOP STEP TREAD / NEZ DE MARCHE HAUT / STUFENPLATTE TOP / TOP CANTO ROMO  
▲ 30x60 (12”x24”) RT 20 mm

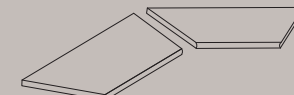

**ANGOLARE INTERNO BORDO TORO**  
INT. CORNER STEP TREAD / ANGLE INT. NEZ DE MARCHE / INNENECKTRITTSTUFE / ANG. INT. CANTO ROMO  
▲ 45x90 (18”x36”) RT 20 mm  
▲ 30x60 (12”x24”) RT 20 mm

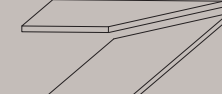

**ANGOLARE ESTERNO BORDO TORO**  
EXT. CORNER STEP TREAD / ANGLE EXT. NEZ DE MARCHE / AUSSENECKTRITTSTUFE / ANG. EXT. CANTO ROMO  
▲ 45x90 (18”x36”) RT 20 mm  
▲ 30x60 (12”x24”) RT 20 mm

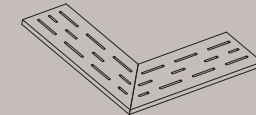

**ANGOLARE GRIGLIA**  
GRID / GRIL / GRILL / ANGULAR REJILLA  
▲ 15x60 (6”x24”) RT 20 mm



**CORDOLO L**  
GLUED “L” TERMINAL / TERMINAL “L” COLLÉ / “L” STÜCK FLIESE GEKLEBT / CANTONERA “L” (PEGADA)  
▲ 60x20x15 (24”x8”x6”) RT 20 mm

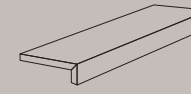

**TERMINALE L**  
GLUED “L” TERMINAL / TERMINAL “L” COLLÉ / “L” STÜCK FLIESE GEKLEBT / TERMINAL “L” (PEGADO)  
▲ 90x45x15 (36”x18”x6”) RT 20 mm  
▲ 60x20x5 (24”x8”x2”) RT 20 mm  
▲ 60x33x5 (13”x24”x2”) RT 20 mm

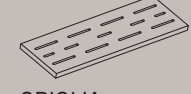

**GRIGLIA**  
GRID / GRIL / GRILL / REJILLA  
▲ 15x60 (6”x24”) RT 20 mm

## FORMATI

FORMATS / FORMATS / FORMATE / FORMATOS

	60x60 24”x24”	30x60 12”x24”	15x30 6”x12”	120x240 (119,5x239)* 48”x96”	30x240 (30x239)* 12”x96”	120x120 (119,5x119,5)* 48”x48”	45x90 18”x36”	60x60 24”x24”	60x60 24”x24”
working size	596x596	297x596		1194x2390	297x2390	1194x1194	446x895	596x596	596x596
	RT	RT	Not RT	RT	RT	RT	RT	RT	RT
	9 mm	9 mm	9 mm	K <sub>2</sub> 20 mm	K <sub>2</sub> 20 mm	K <sub>2</sub> 20 mm	K <sub>2</sub> 20 mm	K <sub>2</sub> 20 mm	K <sub>3</sub> 30 mm
<b>PIETRA DI BRESSA</b>	●▲	●▲	▲	▲	▲	▲	▲	▲	▲
<b>PIETRA DI BAGNOLO</b>	●▲	●▲	▲	▲	▲	▲	▲	▲	▲
<b>PIETRA DI LAVIS</b>	●▲	●▲	▲	▲	▲	▲	▲	▲	▲

\*Formato nominale / Nominal size / Format nominal / Nennformat / Formato nominal

● Natural R9 | ▲ Structured R11

# alpi

SELLA  
15x15 (6"x6")

---

**4**

COLORI/  
COLOURS  
COULEURS  
FARBE  
COLORES

**3**

FORMATI/  
SIZES  
FORMATS  
FORMATE  
FORMATOS

**1**

SUPERFICI/  
FINISHES  
FINITIONS  
OBERFLÄCHEN  
ACABADOS

**1**

SPESSORI/  
THICKNESS  
ÉPAISSEUR  
STÄRKE  
ESPESOR



TONALE  
15x15 (6"x6")



STEVIO  
15x15 (6"x6")

stone effect | alpi

# 4

**COLORI/**  
COLOURS / COULEURS / FARBE / COLORES

STELVIO **V3**



TONALE **V3**



PORDOI **V3**

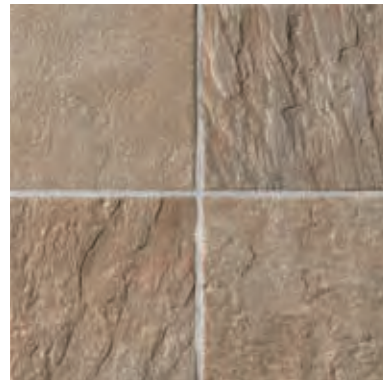

SELLA **V3**



# 3

**FORMATI/**  
SIZES / FORMATS / FORMATE / FORMATOS

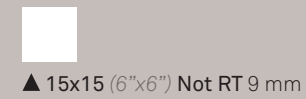
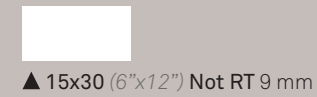
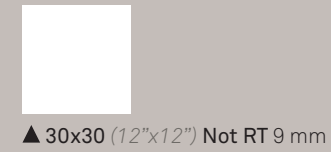

# 4

**PEZZI SPECIALI/**  
TRIMS / PIECES SPECIALES / FORMTEILE /  
PIEZAS ESPECIALES

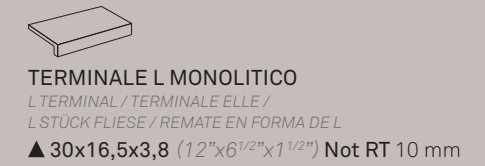
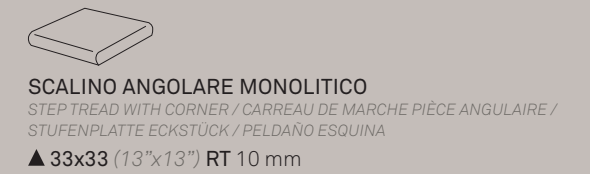
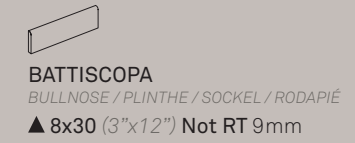

## FORMATI

FORMATS / FORMATS / FORMATE / FORMATOS

	30x30 12"x12"	15x30 6"x12"	15x15 6"x6"
	Not RT	Not RT	Not RT
	9 mm	9 mm	9 mm
STELVIO	▲	▲	▲
TONALE	▲	▲	▲
PORDOI	▲	▲	▲
SELLA	▲	▲	▲

▲ Structured R11

BACK GREY  
60x60 (24"x24") - 30x60 (12"x24")

---

# back

**4**

COLORI/  
COLOURS  
COULEURS  
FARBE  
COLORES

**6**

FORMATI/  
SIZES  
FORMATS  
FORMATE  
FORMATOS

**3**

SUPERFICI/  
FINISHES  
FINITIONS  
OBERFLÄCHEN  
ACABADOS

**3**

SPESSORI/  
THICKNESS  
ÉPAISSEUR  
STÄRKE  
ESPESOR

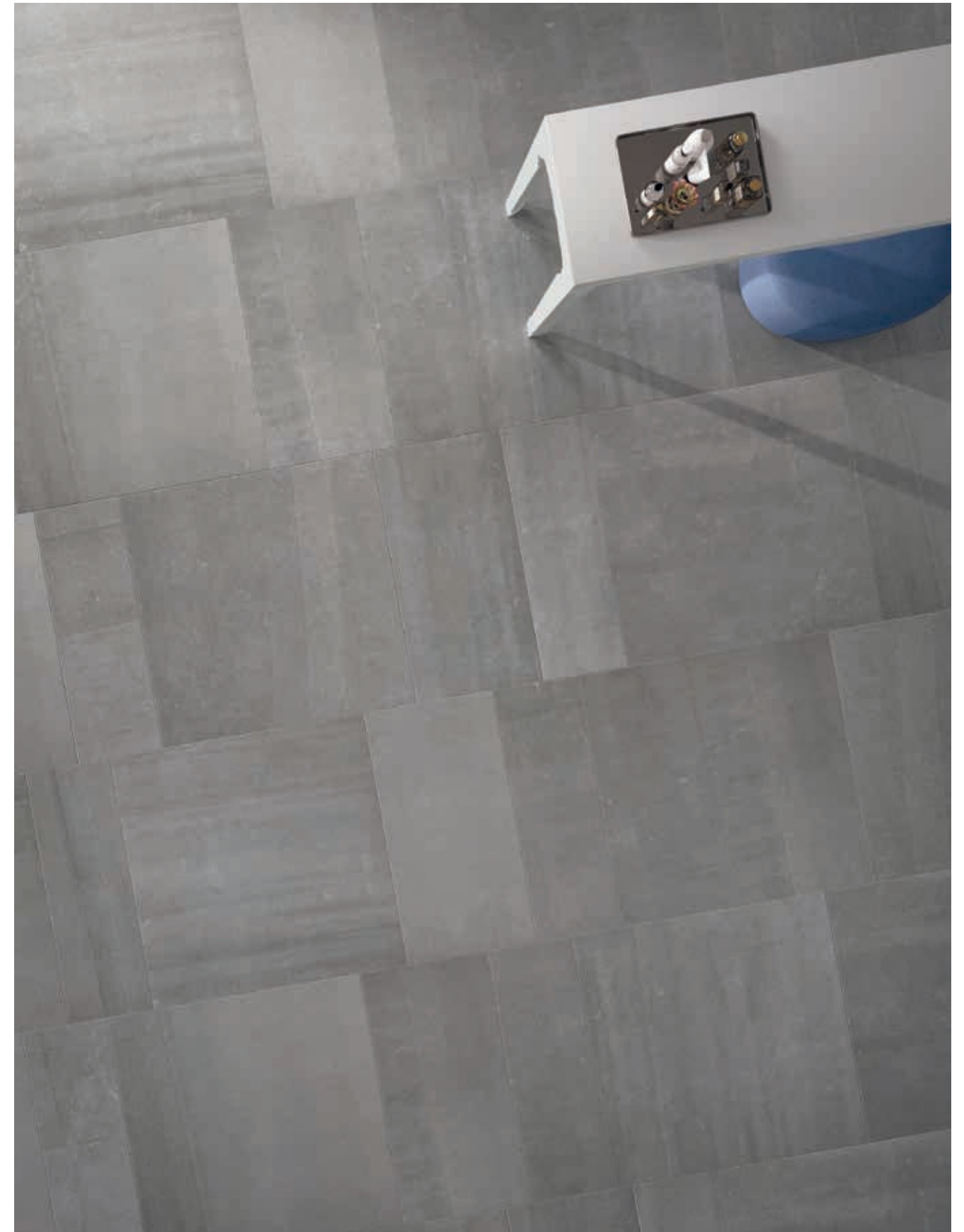



BACK SILVER  
60x60 (24"x24")

---

BACK IVORY  
30x60 (12"x24") - 60x60 (24"x24")

---



stone effect | back

# 5

## COLORI/

COLOURS / COULEURS / FARBE / COLORES

BACK IVORY V2



BACK SILVER V2



BACK GREY V2

LEED COMPLIANT



BACK ANTHRACITE V2

LEED COMPLIANT



# 6

## FORMATI/

SIZES / FORMATS / FORMATE / FORMATOS



● 120x120 (48"x48") RT 9 mm

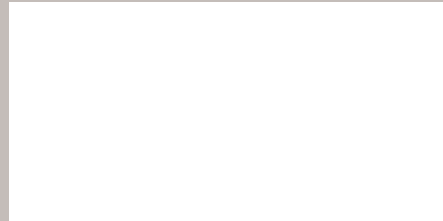

● ▲ 60x120 (24"x48") RT 9 mm

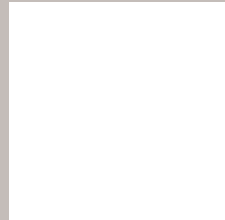

● ▲ 60x60 (24"x24") RT 9 mm  
▲ 60x60 (24"x24") RT ⇒ K2 20 mm



● ▲ 30x60 (12"x24") RT 9 mm



■ 7,5x30 (3"x12") Not RT 8,5 mm

● Natural R9 | ■ Structured R10 | ▲ Grip R11

# 5

## PEZZI SPECIALI/

TRIMS / PIECES SPECIALES / FORMTEILE / PIEZAS ESPECIALES



**BATTISCOPA**  
BULLNOSE / PLINTHE / SOCKEL / RODAPIÉ  
● 7,2x60 (2,8"x24") RT 9 mm

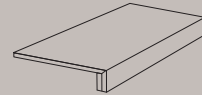

**SCALINO INCOLLATO**  
GLUED STEP TREAD / NEZ DE MARCHE COLLÉ / GEKLEBTE STUFENPLATTE / PELDAÑO CON PERFIL PEGADO  
● 33x60 (13"x24") RT 9 mm



**SCALINO ANGOLARE INCOLLATO**  
GLUED CORNER STEP TREAD / CARREAU DE MARCHE COLLÉ / PIÈCE ANGULAIRE / GEKLEBTE STUFENPLATTE ECKSTÜCK / PELDAÑO ESQUINA CON PERFIL PEGADO  
● 33x33 (13"x13") RT 9 mm

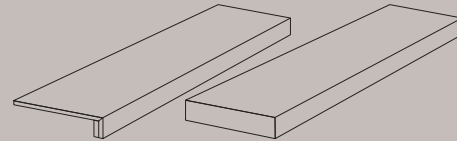

**SCALINO INCOLLATO**  
GLUED STEP TREAD / NEZ DE MARCHE COLLÉ / GEKLEBTE STUFENPLATTE / PELDAÑO CON PERFIL PEGADO  
● ▲ 33x120 (13"x48") RT 9 mm

**SCALINO ANGOLARE INCOLLATO**  
GLUED CORNER STEP TREAD / CARREAU DE MARCHE COLLÉ / PIÈCE ANGULAIRE / GEKLEBTE STUFENPLATTE ECKSTÜCK / PELDAÑO ESQUINA CON PERFIL PEGADO  
● ▲ 33x120 (13"x48") RT 9 mm

## FORMATI

FORMATS / FORMATS / FORMATE / FORMATOS

	120x120 (119,5x119,5)* 48"x48"	60x120 24"x48"	60x60 24"x24"	30x60 12"x24"	7,5x30 3"x12"	60x60 24"x24"
working size	1194x1194	596x1195	596x596	297x596		596x596
	RT	RT	RT	RT	Not RT	RT
	9 mm	9 mm	9 mm	9 mm	8,5mm	K2 20 mm
<b>BACK IVORY</b>			●	●		
<b>BACK SILVER</b>			●	●		
<b>BACK GREY</b>	●	●▲	●▲	●▲	■	▲
<b>BACK ANTHRACITE</b>	●	●▲	●▲	●▲	■	▲

\*Formato nominale / Nominal size / Format nominal / Nennformat / Formato nominal

● Natural R9 | ■ Structured R10 | ▲ Grip R11

# 10

## PEZZI SPECIALI K2/

TRIMS K2 / PIECES SPECIALES K2 / FORMTEILE K2 / PIEZAS ESPECIALES K2

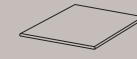

**ANGOLARE BORDO TORO**  
CORNER STEP TREAD / NEZ DE MARCHE ANGULAIRE / STUFENPLATTE ECKSTÜCK / ANGULAR CANTO ROMO  
▲ 30x30 (12"x12") RT 20 mm

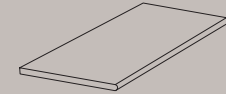

**GRADINO BORDO TORO**  
ROUNDED STEP TREAD / NEZ DE MARCHE ARRONDI / GERUNDET STUFENPLATTE / PELDAÑO CANTO ROMO  
▲ 30x60 (12"x24") RT 20 mm

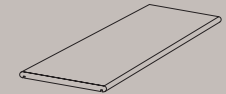

**TOP BORDO TORO**  
TOP STEP TREAD / NEZ DE MARCHE HAUT / STUFENPLATTE TOP / TOP CANTO ROMO  
▲ 30x60 (12"x24") RT 20 mm

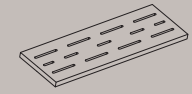

**GRIGLIA**  
GRID / GRIL / GRILL / REJILLA  
▲ 15x60 (6"x24") RT 20 mm

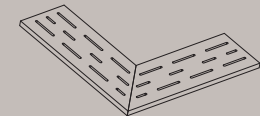

**ANGOLARE GRIGLIA**  
GRID / GRIL / GRILL / ANGULAR REJILLA  
▲ 15x60 (6"x24") RT 20 mm

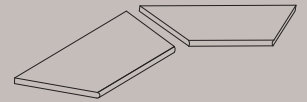

**ANGOLARE INTERNO BORDO TORO**  
INT. CORNER STEP TREAD / ANGLE INT. NEZ DE MARCHE / INNENECKTRITTSTUFE / ANG. INT. CANTO ROMO  
▲ 30x60 (12"x24") RT 20 mm

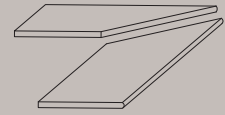

**ANGOLARE ESTERNO BORDO TORO**  
EXT. CORNER STEP TREAD / ANGLE EXT. NEZ DE MARCHE / AUSSENECKTRITTSTUFE / ANG. EXT. CANTO ROMO  
▲ 30x60 (12"x24") RT 20 mm

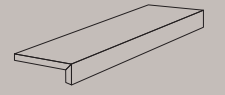

**TERMINALE L**  
GLUED "L" TERMINAL / TERMINAL "L" COLLÉ / "L" STÜCK FLIESE GEKLEBT / TERMINAL "L" (PEGADO)  
▲ 60x20x5 (24"x8"x2") RT 20 mm  
▲ 60x33x5 (13"x24"x2") RT 20 mm

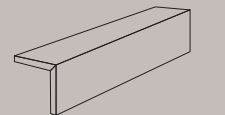

**CORDOLO L**  
GLUED "L" TERMINAL / TERMINAL "L" COLLÉ / "L" STÜCK FLIESE GEKLEBT / CANTONERA "L" (PEGADA)  
▲ 60x20x15 (24"x8"x6") RT 20 mm

stone effect | back

# sight

SIGHT ANTHRACITE  
60x60 (24"x24") K2 20 mm

2

COLORI/  
COLOURS  
COULEURS  
FARBE  
COLORES

1

FORMATI/  
SIZES  
FORMATS  
FORMATE  
FORMATOS

1

SUPERFICI/  
FINISHES  
FINITIONS  
OBERFLÄCHEN  
ACABADOS

1

SPESSORI/  
THICKNESS  
ÉPAISSEUR  
STÄRKE  
ESPEJOR





# 2

## COLORI/

COLOURS / COULEURS / FARBE / COLORES

SIGHT ANTHRACITE V3



SIGHT GREY V3

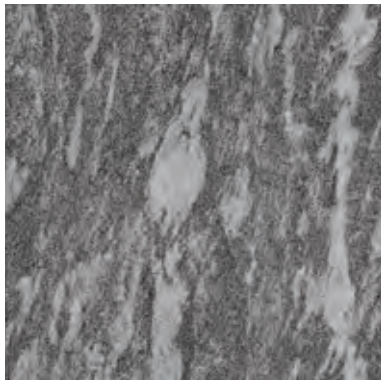

# 1

## FORMATI/

SIZES / FORMATS / FORMATE / FORMATOS

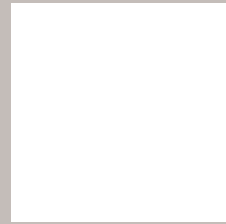

▲ 60x60 (24"x24") RT **K2** 20 mm

▲ Structured R11

# 10

## PEZZI SPECIALI K<sub>2</sub>/

TRIMS K<sub>2</sub> / PIECES SPECIALES K<sub>2</sub> / FORMTEILE K<sub>2</sub> / PIEZAS ESPECIALES K<sub>2</sub>

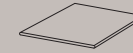

**ANGOLARE BORDO TORO**  
CORNER STEP TREAD / NEZ DE MARCHE ANGULAIRE / STUFENPLATTE ECKSTÜCK / ANGULAR CANTO ROMO  
▲ 30x30 (12"x12") RT 20 mm

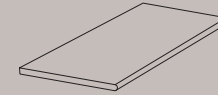

**GRADINO BORDO TORO**  
ROUNDED STEP TREAD / NEZ DE MARCHE ARRONDI / GERUNDET STUFENPLATTE / PELDAÑO CANTO ROMO  
▲ 30x60 (12"x24") RT 20 mm

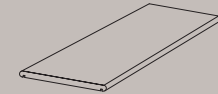

**TOP BORDO TORO**  
TOP STEP TREAD / NEZ DE MARCHE HAUT / STUFENPLATTE TOP / TOP CANTO ROMO  
▲ 30x60 (12"x24") RT 20 mm

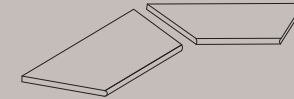

**ANGOLARE INTERNO BORDO TORO**  
INT. CORNER STEP TREAD / ANGLE INT. NEZ DE MARCHE / INNENECKTRITTSTUFE / ANG. INT. CANTO ROMO  
▲ 30x60 (12"x24") RT 20 mm

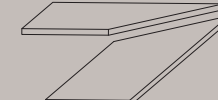

**ANGOLARE ESTERNO BORDO TORO**  
EXT. CORNER STEP TREAD / ANGLE EXT. NEZ DE MARCHE / AUSSENECKTRITTSTUFE / ANG. EXT. CANTO ROMO  
▲ 30x60 (12"x24") RT 20 mm

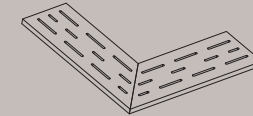

**ANGOLARE GRIGLIA**  
GRID / GRIL / GRILL / ANGULAR REJILLA  
▲ 15x60 (6"x24") RT 20 mm

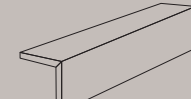

**CORDOLO L**  
GLUED "L" TERMINAL / TERMINAL "L" COLLÉ / "L" STÜCK FLIESE GEKLEBT / CANTONERA "L" (PEGADA)  
▲ 60x20x15 (24"x8"x6") RT 20 mm

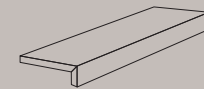

**TERMINALE L**  
GLUED "L" TERMINAL / TERMINAL "L" COLLÉ / "L" STÜCK FLIESE GEKLEBT / TERMINAL "L" (PEGADO)  
▲ 60x20x5 (24"x8"x2") RT 20 mm  
▲ 60x33x5 (13"x24"x2") RT 20 mm

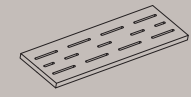

**GRIGLIA**  
GRID / GRIL / GRILL / REJILLA  
▲ 15x60 (6"x24") RT 20 mm

## FORMATI

FORMATS / FORMATS / FORMATE / FORMATOS

	60x60 24"x24"
working size	596x596
	RT
	<b>K2</b> 20 mm
<b>SIGHT ANTHRACITE</b>	▲
<b>SIGHT GREY</b>	▲

▲ Structured R11

# sunrise

**3**

COLORI/  
COLOURS  
COULEURS  
FARBE  
COLORES

**3**

FORMATI/  
SIZES  
FORMATS  
FORMATE  
FORMATOS

**1**

SUPERFICI/  
FINISHES  
FINITIONS  
OBERFLÄCHEN  
ACABADOS

**1**

SPESSORI/  
THICKNESS  
ÉPAISSEUR  
STÄRKE  
ESPESOR

SMOKE  
30x60 (12"x24")



QUARTZ  
60x60 (24"x24") - 30x60 (12"x24")

---



GOLDEN  
60x60 (24"x24") - 30x60 (12"x24")

---

stone effect | sunrise

### 3 COLORI/ COLOURS / COULEURS / FARBE / COLORES

QUARTZ **V1**



GOLDEN **V1**

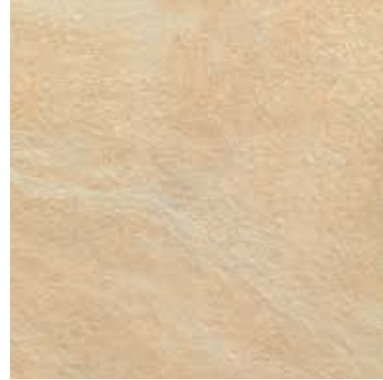

SMOKE **V1**



### 1 DECORI/ DECORS / PIECES SPECIALES / FORMTEILE / PIEZAS ESPECIALES

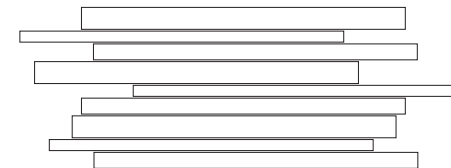

STRIPS ■ 30x60 (12"x24") RT 9 mm



QUARTZ



GOLDEN



SMOKE

### 3 FORMATI/ SIZES / FORMATS / FORMATE / FORMATOS

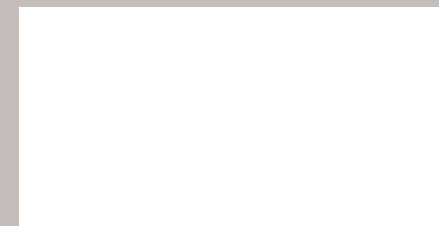

■ 60x120 (24"x48") RT 9 mm

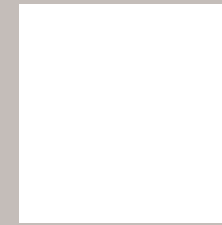

■ 60x60 (24"x24") RT 9 mm



■ 30x60 (12"x24") RT 9 mm

### 1 PEZZI SPECIALI/ TRIMS / PIECES SPECIALES / FORMTEILE / PIEZAS ESPECIALES



BATTISCOPA  
BULLNOSE / PLINTHE / SOCKEL / RODAPIÉ  
■ 7,2x60 (2,8"x24") RT 9 mm

### FORMATI FORMATS / FORMATS / FORMATE / FORMATOS

	60x120 24"x48"	60x60 24"x24"	30x60 12"x24"
working size	596x1195	596x596	297x596
	RT	RT	RT
	9 mm	9 mm	9 mm
<b>QUARTZ</b>	■	■	■
<b>GOLDEN</b>		■	■
<b>SMOKE</b>		■	■



# marble

EFFECT

152 / 9Cento

164 / Interno4

174 / Eclectic

184 / Elements Lux

METAMORFOSI 60x120 (24"x48") -  
RAGGIO VERDE 120x278 (48"x110") -  
OMBRA MOCA 60x120 (24"x48")

# 9cento

**6**

COLORI/  
COLOURS  
COULEURS  
FARBE  
COLORES

**5**

FORMATI/  
SIZES  
FORMATS  
FORMATE  
FORMATOS

**1**

SUPERFICIE/  
FINISHE  
FINITION  
OBERFLÄCHEN  
ACABADO

**2**

SPESSORI/  
THICKNESS  
ÉPAISSEUR  
STÄRKE  
ESPESOR





RIFLESSO BIANCO  
120x120 (48"x48")



ALBA ORO  
60x60 (24"x24")

marble effect | 9cento



AURORA BEIGE  
120x120 (48"x48")

marble effect | 9cento





RAGGIO VERDE  
120x278 (48"x110")

METAMORFOSI  
60x120 (24"x48")

OMBRA MOCA  
120x120 (48"x48")

REALIZZATI SU MISURA / CUSTOM MADE TRIMS  
CORNICE A L 15x5 (5<sup>7</sup>/<sub>8</sub>"x1<sup>15</sup>/<sub>16</sub>")  
ZOCCOLO A L 15x3 (5<sup>7</sup>/<sub>8</sub>"x1<sup>3</sup>/<sub>16</sub>")



marble effect | 9cento

# 6

**COLORI/**  
COLOURS / COULEURS / FARBE / COLORES

OMBRA MOCA **V2**

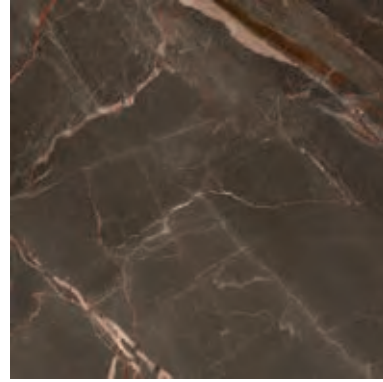

RAGGIO VERDE **V2**



ALBA ORO **V2**



AURORA BEIGE **V2**

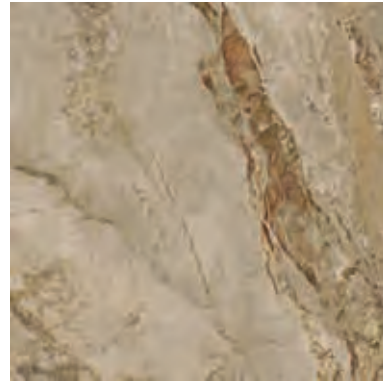

RIFLESSO BIANCO **V2**

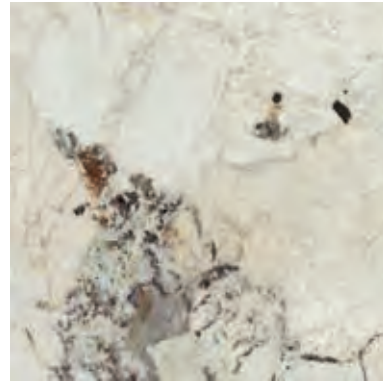

METAMORFOSI **V3**

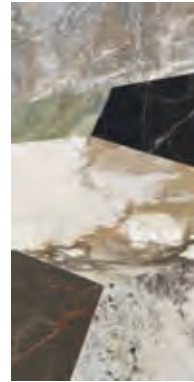

# 5

**FORMATI/**  
SIZES / FORMATS / FORMATE / FORMATOS



◆ 120x278 (48"x110") RT 6 mm



◆ 120x120 (48"x48") RT 9 mm

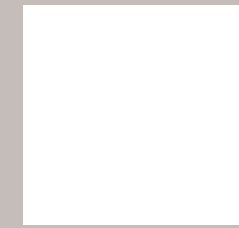

◆ 60x60 (24"x24") RT 9 mm

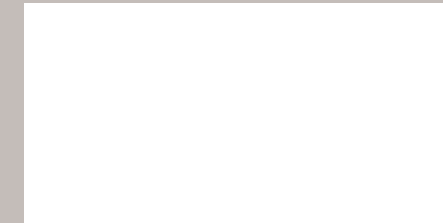

◆ 60x120 (24"x48") RT 9 mm

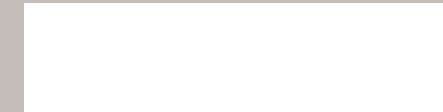

◆ 30x120 (12"x48") RT 9 mm

◆ Lappato

## 2 DECORI/ DECORS

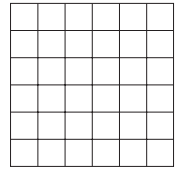

MOSAICO ◆ 30x30 (12"x12") RT 9 mm  
(TESSERE: 4,8x4,8 (1 7/8"x1 7/8"))

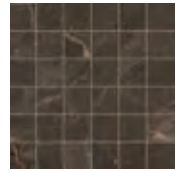

OMBRA MOCA



RAGGIO VERDE



ALBA ORO



AURORA BEIGE



RIFLESSO BIANCO

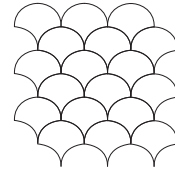

MOSAICO PALM MIX ◆ 35x35 (13 25/32"x13 25/32") RT 9 mm  
(TESSERE: 10x10 (3 15/16"x3 15/16"))



PALM MIX  
(RIFLESSO BIANCO-OMBRA MOCA-RAGGIO VERDE)

## 6 PEZZI SPECIALI/ TRIMS

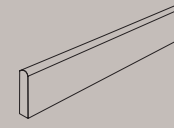

BATTISCOPA  
BULLNOSE / PLINTHE / SOCKEL / RODAPIÉ  
◆ 4,6x120 (1 13/16"x48") RT 9 mm  
◆ 7,2x60 (2,8"x24") RT 9 mm

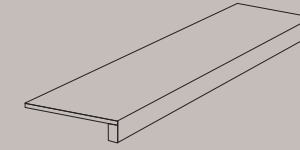

SCALINO INCOLLATO  
GLUED STEP TREAD / NEZ DE MARCHE COLLÉ / GEKLEBTE STUFENPLATTE / PELDAÑO CON PERFIL PEGADO  
◆ 33x120 (13"x48") RT 9 mm

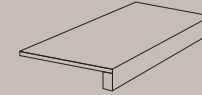

SCALINO INCOLLATO  
GLUED STEP TREAD / NEZ DE MARCHE COLLÉ / GEKLEBTE STUFENPLATTE / PELDAÑO CON PERFIL PEGADO  
◆ 33x60 (13"x24") RT 9 mm

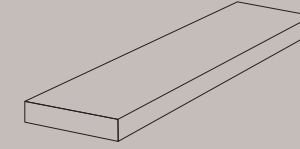

SCALINO ANGOLARE INCOLLATO  
GLUED CORNER STEP TREAD / CARREAU DE MARCHE COLLÉ / PIÈCE ANGULAIRE / GEKLEBTE STUFENPLATTE ECKSTÜCK / PELDAÑO ESQUINA CON PERFIL PEGADO  
◆ 33x120 (13"x48") RT 9 mm



SCALINO ANGOLARE INCOLLATO  
GLUED CORNER STEP TREAD / CARREAU DE MARCHE COLLÉ / PIÈCE ANGULAIRE / GEKLEBTE STUFENPLATTE ECKSTÜCK / PELDAÑO ESQUINA CON PERFIL PEGADO  
◆ 33x33 (13"x13") RT 9 mm

### FORMATI

FORMATS / FORMATS / FORMATE / FORMATOS

	120x278 (119,5x278)* 48"x110"	120x120 (119,5x119,5)* 48"x48"	60x120 24"x48"	30x120 12"x48"	60x60 24"x24"
working size	1194x2778	1194x1194	596x1195	297x1195	596x596
	RT	RT	RT	RT	RT
	6 mm	9 mm	9 mm	9 mm	9 mm
AURORA BEIGE	◆	◆	◆	◆	◆
RAGGIO VERDE	◆	◆	◆	◆	◆
OMBRA MOCA		◆	◆	◆	◆
ALBA ORO		◆	◆	◆	◆
RIFLESSO BIANCO		◆	◆	◆	◆
METAMORFOSI			◆		

\*Formato nominale / Nominal size / Format nominal / Nennformat / Formato nominal

◆ Lappato

BRECCIA TORTONA  
120x278 (48"x110") - 120x120 (48"x48")

# interno4

**6**

COLORI/  
COLOURS  
COULEURS  
FARBE  
COLORES

**7**

FORMATI/  
SIZES  
FORMATS  
FORMATE  
FORMATOS

**2**

SUPERFICI/  
FINISHES  
FINITIONS  
OBERFLÄCHEN  
ACABADOS

**2**

SPESSORI/  
THICKNESS  
ÉPAISSEUR  
STÄRKE  
ESPESOR





RENOIR ISOLA  
80X80 (32"x32")



CALACATTA SAN BABILA  
120x278 (48"x110") - 120x120 (48"x48")

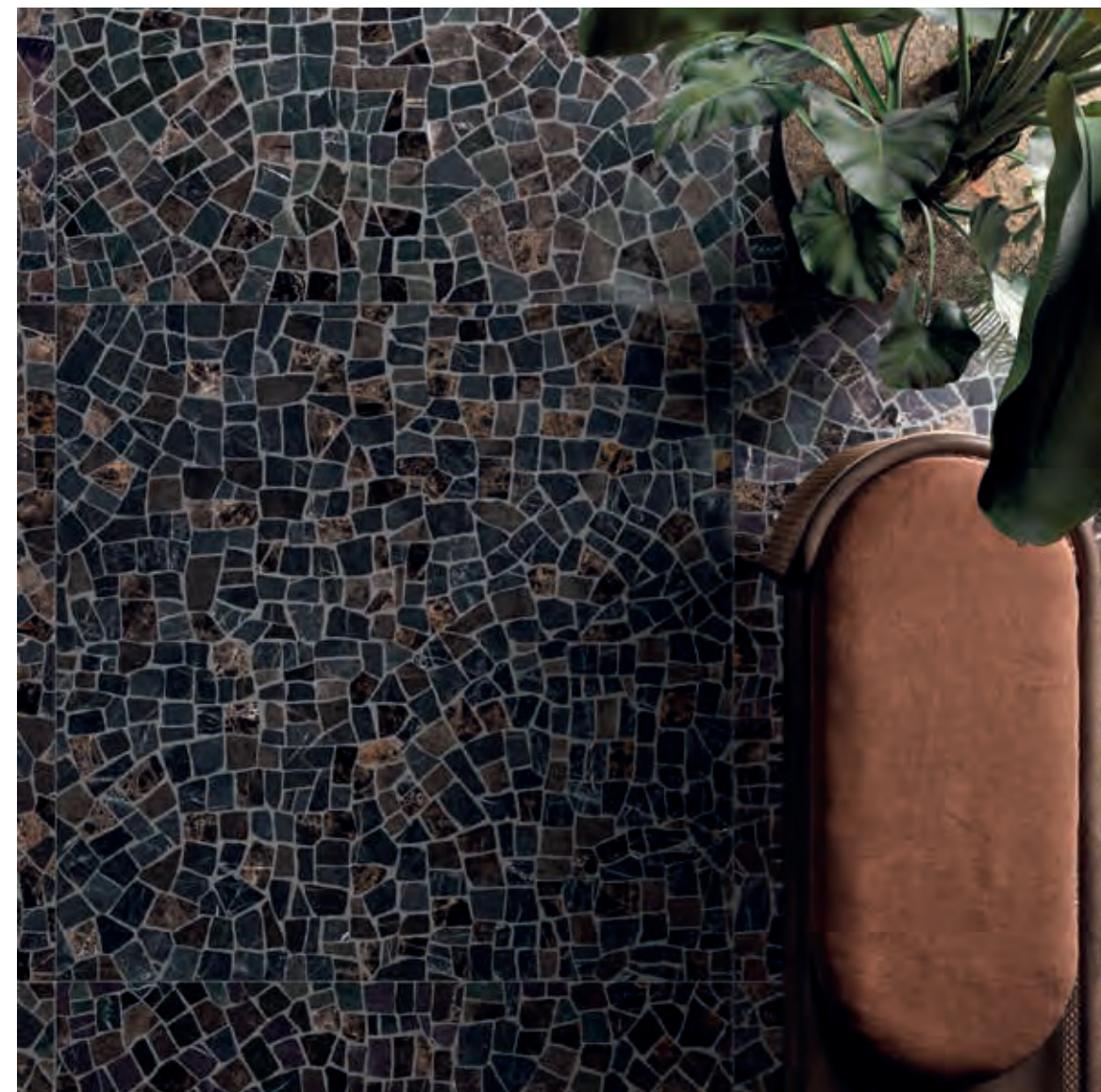

CARNICO BRERA  
120x120 (48"x48")  
MOSAICO ROMBI CARNICO BRERA  
30,5x35,2 (12<sup>1/16</sup>"x13<sup>7/8</sup>")

PALLADIANA DARK  
120x120 (48"x48")

# 6

**COLORI/**  
COLOURS / COULEURS / FARBE / COLORES

BRECCIA TORTONA **V2**



RENOIR ISOLA **V2**



CALACATTA SAN BABILA **V2**



CARNICO BRERA **V3**



PALLADIANA LIGHT **V2**



PALLADIANA DARK **V2**

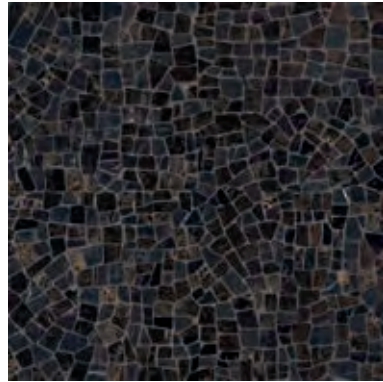

# 7

**FORMATI/**  
SIZES / FORMATS / FORMATE / FORMATOS



◆ 120x278 (48"x110") RT 6 mm



◆ 80x160 (32"x64") RT 9 mm

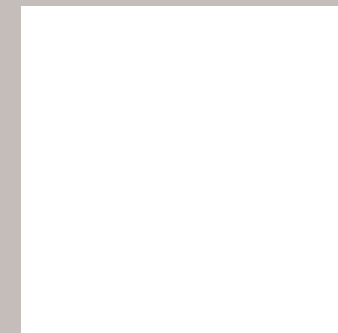

●◆ 80x80 (32"x32") RT 9 mm

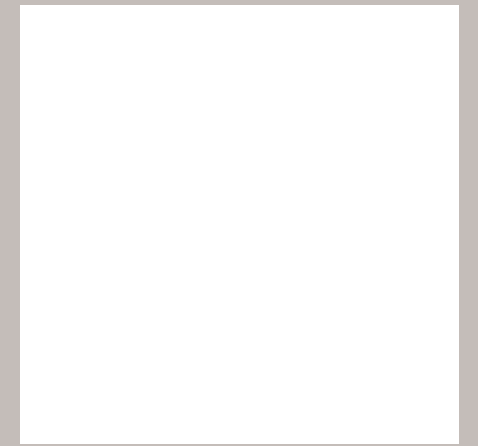

◆ 120x120 (48"x48") RT 9 mm

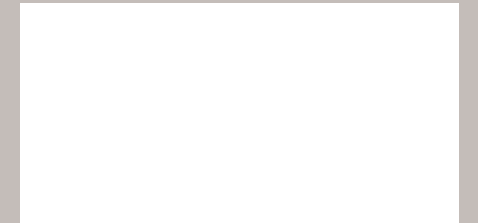

●◆ 60x120 (24"x48") RT 9 mm



◆ 30x120 (12"x48") RT 9 mm

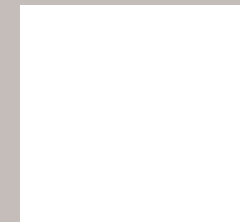

◆ 60x60 (24"x24") RT 9 mm

● Natural R9 | ◆ Lappato

marble effect | interno4

# 6

## DECORI/

DECORS / PIECES SPECIALES / FORMTEILE /  
PIEZAS ESPECIALES

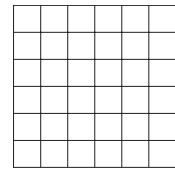

**MOSAICO** ◆ 30x30 (12"x12") RT 9 mm  
(TESSERE: 4,8x4,8 - 17/8"x17/8")



BRECCIA TORTONA

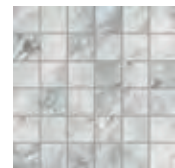

RENOIR ISOLA



CALACATTA SAN BABILA



CARNICO BRERA

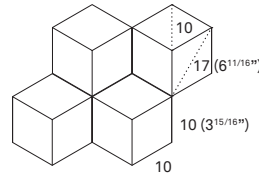

**MOSAICO ROMBI**  
◆ 30,5x35,2 (12<sup>1/16</sup>"x13<sup>7/8</sup>") RT 9 mm



BRECCIA TORTONA



RENOIR ISOLA



CALACATTA SAN BABILA



CARNICO BRERA



**COPRISPIGOLO\***  
CORNER / ELÉMENT DE REVÊTEMENT /  
ABDECKELEMENTES / ELEMENTO DE COBERTURA  
◆ 1x90 (26/64"x36") RT 6 mm



**ANGOLARE COPRISPIGOLO\***  
ANGULAR CORNER / ELÉMENT DE REVÊTEMENT ANGULAIRE /  
ECKE ABDECKELEMENTES / ELEMENTO DE COBERTURA ANGULAR  
◆ 1x1 (26/64"x26/64") RT 6 mm

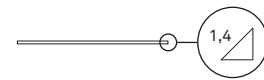

**COPRISPIGOLO\***  
CORNER / ELÉMENT DE REVÊTEMENT /  
ABDECKELEMENTES / ELEMENTO DE COBERTURA  
◆ 1,4x60 (3/64"x24") RT 9 mm



**ANGOLARE COPRISPIGOLO\***  
ANGULAR CORNER / ELÉMENT DE REVÊTEMENT ANGULAIRE /  
ECKE ABDECKELEMENTES / ELEMENTO DE COBERTURA ANGULAR  
◆ 1,4x1,4 (3/64"x3/64") RT 9 mm

\* Disponibile in tutti i colori (no Palladiana), tagliato dal fondo /  
Available in all colours (no Palladiana), cut from floor tile / Disponible  
dans toutes les couleurs (no Palladiana), découpées du carrelage /  
Erhältlich in allen Farben (kein Palladiana), aus Bodenfliesen  
geschnitten / Disponible en todos los colores (no Palladiana),  
cortado de baldosas.

# 6

## PEZZI SPECIALI/

TRIMS / PIECES SPECIALES / FORMTEILE /  
PIEZAS ESPECIALES



**BATTISCOPA**  
BULLNOSE / PLINTHE / SOCKEL / RODAPIÉ  
◆◆ 4,6x120 (1<sup>13/16</sup>"x48") RT 9 mm  
◆◆ 7x80 (2<sup>3/4</sup>"x32") RT 9 mm

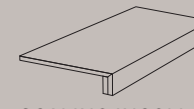

**SCALINO INCOLLATO**  
GLUED STEP TREAD / NEZ DE MARCHE COLLÉ /  
GEKLEBTE STUFENPLATTE / PELDAÑO CON PERFIL PEGADO  
◆◆ 33x60 (13"x24") RT 9 mm



**SCALINO ANGOLARE INCOLLATO**  
GLUED CORNER STEP TREAD / CARREAU DE MARCHE COLLÉ  
PIÈCE ANGULAIRE / GEKLEBTE STUFENPLATTE ECKSTÜCK /  
PELDAÑO ESQUINA CON PERFIL PEGADO  
◆◆ 33x33 (13"x13") RT 9 mm

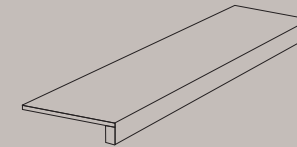

**SCALINO INCOLLATO**  
GLUED STEP TREAD / NEZ DE MARCHE COLLÉ /  
GEKLEBTE STUFENPLATTE / PELDAÑO CON PERFIL PEGADO  
◆◆ 33x120 (13"x48") RT 9 mm

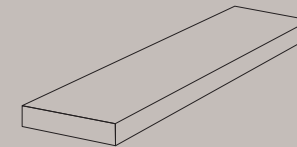

**SCALINO ANGOLARE INCOLLATO**  
GLUED CORNER STEP TREAD / CARREAU DE MARCHE  
COLLÉ PIÈCE ANGULAIRE / GEKLEBTE STUFENPLATTE  
ECKSTÜCK / PELDAÑO ESQUINA CON PERFIL PEGADO  
◆◆ 33x120 (13"x48") RT 9 mm

## FORMATI

SIZES / FORMATS / FORMATE / FORMATOS

	120x278 (119,5x278)* 48"x110"	80x160 (80x159,2)* 32"x64"	120x120 (119,5x119,5)* 48"x48"	60x120 24"x48"	30x120 12"x48"	80x80 32"x32"	60x60 24"x24"
working size	1194x2778	795x1592	1194x1194	596x1195	297x1195	795x795	596x596
	RT	RT	RT	RT	RT	RT	RT
	6 mm	9 mm	9 mm	9 mm	9 mm	9 mm	9 mm
<b>BRECCIA TORTONA</b>	◆	◆	◆	◆◆	◆	◆◆	
<b>RENOIR ISOLA</b>	◆	◆	◆	◆◆	◆	◆◆	
<b>CALACATTA SAN BABILA</b>	◆	◆	◆	◆◆	◆	◆◆	
<b>CARNICO BRERA</b>	◆	◆	◆	◆◆	◆	◆◆	
<b>PALLADIANA DARK</b>			◆				◆
<b>PALLADIANA LIGHT</b>			◆				◆

\*Formato nominale / Nominal size / Format nominal / Nennformat / Formato nominal

● Natural R9 | ◆ Lappato



ONIRIC WHITE  
120x120 (48"x48")

---

# eclectic

**4**

COLORI/  
COLOURS  
COULEURS  
FARBE  
COLORES

**6**

FORMATI/  
SIZES  
FORMATS  
FORMATE  
FORMATOS

**3**

SUPERFICI/  
FINISHES  
FINITIONS  
OBERFLÄCHEN  
ACABADOS

**2**

SPESSORI/  
THICKNESS  
ÉPAISSEUR  
STÄRKE  
ESPEJOR



MISTIQ WHITE  
120x278 (48"x110") - 120x120 (48"x48")



marble effect | eclectic

PERSIAN GREY  
120x278 (48"x110") - 60x120 (24"x48")



PINSTRIPED DARK  
120x278 (48"x110")

marble effect | eclectic

# 4

**COLORI/**  
COLOURS / COULEURS / FARBE / COLORES

ONIRIC WHITE **V2**



MISTIQ WHITE **V2**

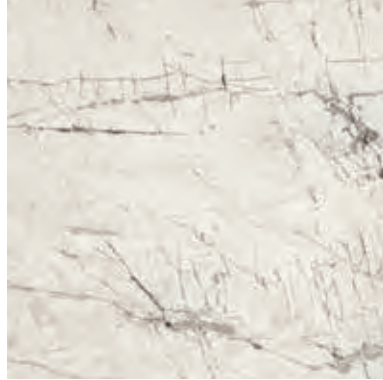

PINSTRIPED DARK **V2**

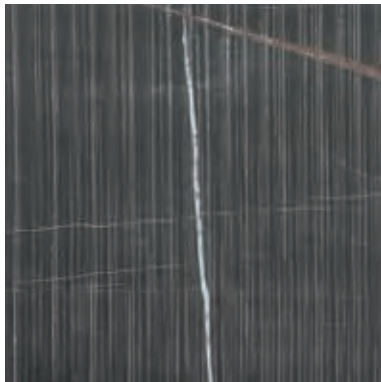

PERSIAN GREY **V2**

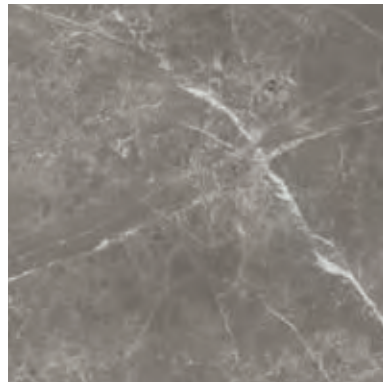

# 6

**FORMATI/**  
SIZES / FORMATS / FORMATE / FORMATOS

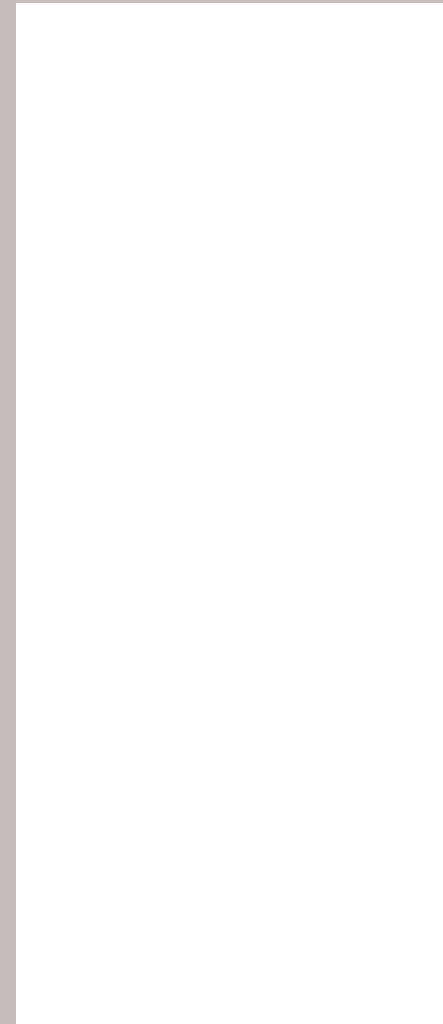

◆ ✕ 120x278 (48"x110") RT 6 mm



◆ ✕ 120x120 (48"x48") RT 9 mm

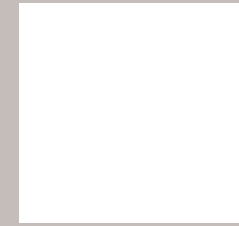

● ◆ ✕ 60x60 (24"x24") RT 9 mm

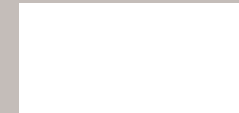

● ◆ ✕ 30x60 (12"x24") RT 9 mm

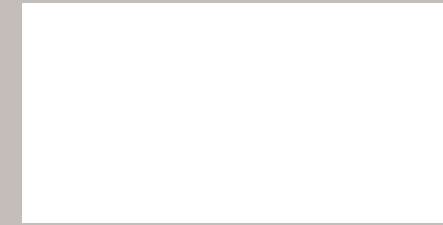

● ◆ ✕ 60x120 (24"x48") RT 9 mm



◆ ✕ 30x120 (12"x48") RT 9 mm

● Natural R9 | ◆ Lappato | ✕ Silky

# 3

## DECORI/

DECORS / PIECES SPECIALES / FORMTEILE /  
PIEZAS ESPECIALES

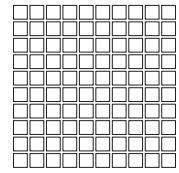

**MOSAICO** ◆× 30x30 (12"x12") RT 9 mm  
(TESSERE: 2,8x2,8 - 1 1/8"x1 1/8")



ONIRIC WHITE



MISTIQ WHITE



PERSIAN GREY



PINSTRIPE DARK

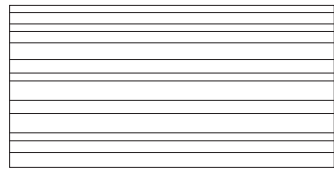

**NEXT** ●× 30x60 (12"x24") RT 12 mm



ONIRIC WHITE



MISTIQ WHITE



PERSIAN GREY



**BACCHETTA GOLD** ● 0,5x60 (3/16"x24") RT 8 mm

# 5

## PEZZI SPECIALI/

TRIMS / PIECES SPECIALES / FORMTEILE /  
PIEZAS ESPECIALES



**BATTISCOPA**  
BULLNOSE / PLINTHE / SOCKEL / RODAPIÉ  
●◆× 7,2x60 (2.8"x24") RT 9 mm

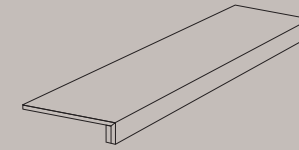

**SCALINO INCOLLATO**  
GLUED STEP TREAD / NEZ DE MARCHE COLLÉ / GEKLEBTE STUFENPLATTE / PELDAÑO CON PERFIL PEGADO  
◆× 33x120 (13"x48") RT 9 mm

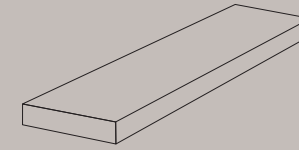

**SCALINO ANGOLARE INCOLLATO**  
GLUED CORNER STEP TREAD / CARREAU DE MARCHE COLLÉ PIÈCE ANGULAIRE / GEKLEBTE STUFENPLATTE ECKSTÜCK / PELDAÑO ESQUINA CON PERFIL PEGADO  
◆× 33x120 (13"x48") RT 9 mm

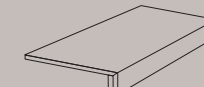

**SCALINO INCOLLATO**  
GLUED STEP TREAD / NEZ DE MARCHE COLLÉ / GEKLEBTE STUFENPLATTE / PELDAÑO CON PERFIL PEGADO  
◆× 33x60 (13"x24") RT 9 mm

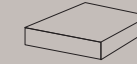

**SCALINO ANGOLARE INCOLLATO**  
GLUED CORNER STEP TREAD / CARREAU DE MARCHE COLLÉ PIÈCE ANGULAIRE / GEKLEBTE STUFENPLATTE ECKSTÜCK / PELDAÑO ESQUINA CON PERFIL PEGADO  
◆× 33x33 (13"x13") RT 9 mm

## FORMATI

SIZES / FORMATS / FORMATE / FORMATOS

	120x278 (119,5x278)* 48"x110"	120x120 (119,5x119,5)* 48"x48"	60x120 24"x48"	30x120 12"x48"	60x60 24"x24"	30x60 12"x24"
working size	1194x2778	1194x1194	596x1195	297x1195	596x596	297x596
	RT	RT	RT	RT	RT	RT
	6 mm	9 mm	9 mm	9 mm	9mm	9 mm
<b>ONIRIC WHITE</b>	◆	◆	●◆	◆	●◆	●◆
<b>MISTIQ WHITE</b>	◆	◆	●◆	◆	●◆	●◆
<b>PERSIAN GREY</b>	×	×	×	×	×	×
<b>PINSTRIPE DARK</b>	×	×	×	×	×	×

\*Formato nominale / Nominal size / Format nominal / Nennformat / Formato nominal

● Natural R9 | ◆ Lappato | × Silky

CALACATTA GOLD  
120x278 (48"x110")

# elements lux

7

COLORI/  
COLOURS  
COULEURS  
FARBE  
COLORES

7

FORMATI/  
SIZES  
FORMATS  
FORMATE  
FORMATOS

2

SUPERFICI/  
FINISHES  
FINITIONS  
OBERFLÄCHEN  
ACABADOS

2

SPESSORI/  
THICKNESS  
ÉPAISSEUR  
STÄRKE  
ESPEJOR



marble effect | elements lux



ELEMENTS LUX SILVER GREY  
120x278 (48"x110")  
60x120 (24"x48")



ELEMENTS LUX EMPERADOR  
120x178 (48"x110")

ELEMENTS DESIGN BEIGE  
120x120 (48"x48")

---



ELEMENTS LUX PORT LAURENT  
120x278 (48"x110") - 60x120 (24"x48")

---



# 7 COLORI/ COLOURS / COULEURS / FARBE / COLORES

E. LUX CALACATTA V2

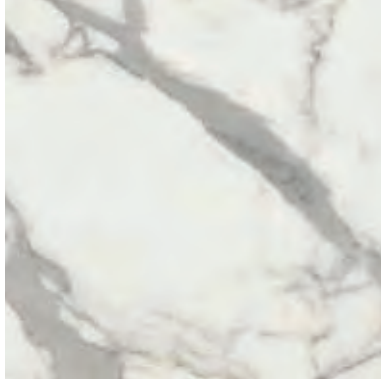

E. LUX SILVER GREY V2



E. LUX CALACATTA GOLD V2



E. LUX PORT LAURENT V2

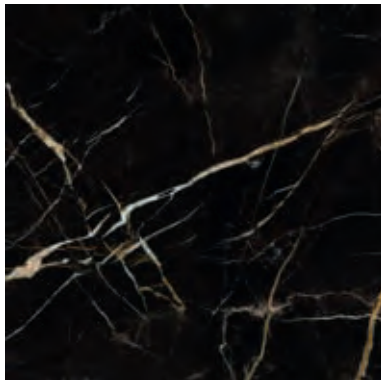

E. LUX CREMA BEIGE V2



E. LUX EMPERADOR V2



E. LUX LINCOLN V1

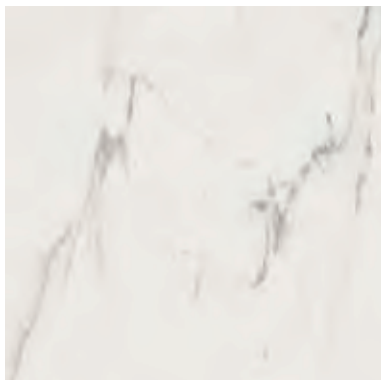

# 7 FORMATI/ SIZES / FORMATS / FORMATE / FORMATOS

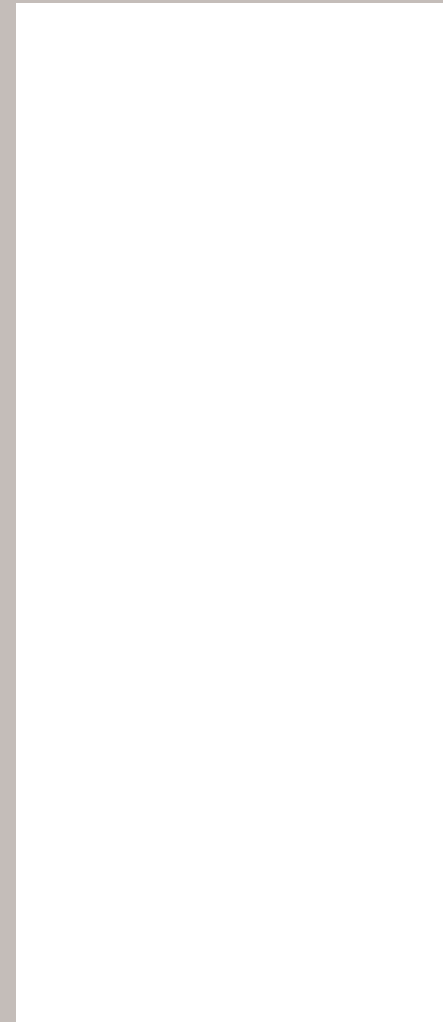

◆ 120x278 (48"x110") RT 6 mm



◆ 120x240 (48"x96") RT 9 mm



◆ 120x120 (48"x48") RT 9 mm

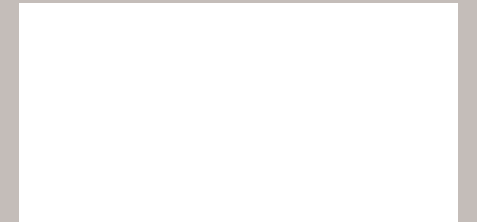

●◆ 60x120 (24"x48") RT 9 mm



◆ 20x120 (8"x48") RT 9 mm

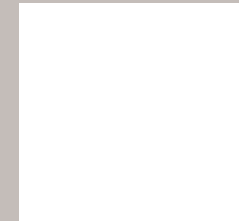

●◆ 60x60 (24"x24") RT 9 mm



●◆ 30x60 (12"x24") RT 9 mm

● Natural R9 | ◆ Lappato

marble effect | elements lux

# 3

## DECORI/

DECORS / PIECES SPECIALES / FORMTEILE /  
PIEZAS ESPECIALES

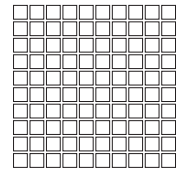

**MOSAICO** ◆ 30x30 (12"x12") RT 9 mm  
(TESSERE: 2,8x2,8 - 11/16"x11/16")



CALACATTA



SILVER GREY

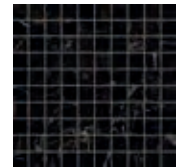

PORT LAURENT



CREMA BEIGE

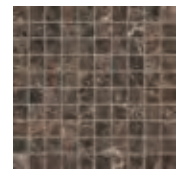

EMPERADOR



LINCOLN



CALACATTA GOLD

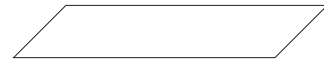

**CHEVRON DX** ◆ 10x59 (4"x24") RT 9 mm



**CHEVRON SX** ◆ 10x59 (4"x24") RT 9 mm



CALACATTA



SILVER GREY



PORT LAURENT



CREMA BEIGE



EMPERADOR



LINCOLN



CALACATTA GOLD

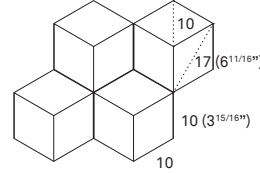

**MOSAICO ROMBI**  
◆ 30,5x35,2 (12<sup>1/16</sup>"x13<sup>7/8</sup>") RT 9 mm



Port Laurent / Silver Grey / Lincoln

# 5

## PEZZI SPECIALI/

TRIMS / PIECES SPECIALES / FORMTEILE /  
PIEZAS ESPECIALES



**BATTISCOPA**  
BULLNOSE / PLINTHE / SOCKEL / RODAPIÉ  
●◆ 7,2x60 (2.8"x24") RT 9 mm

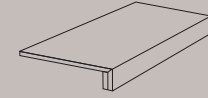

**SCALINO INCOLLATO**  
GLUED STEP TREAD / NEZ DE MARCHE COLLÉ /  
GEKLEBTE STUFENPLATTE / PELDAÑO CON PERFIL PEGADO  
●◆ 33x60 (13"x24") RT 9 mm



**SCALINO ANGOLARE INCOLLATO**  
GLUED CORNER STEP TREAD / CARREAU DE MARCHE COLLÉ  
PIÈCE ANGULAIRE / GEKLEBTE STUFENPLATTE ECKSTÜCK /  
PELDAÑO ESQUINA CON PERFIL PEGADO  
●◆ 33x33 (13"x13") RT 9 mm

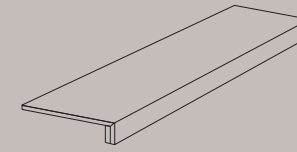

**SCALINO INCOLLATO**  
GLUED STEP TREAD / NEZ DE MARCHE COLLÉ /  
GEKLEBTE STUFENPLATTE / PELDAÑO CON PERFIL PEGADO  
●◆ 33x120 (13"x48") RT 9 mm

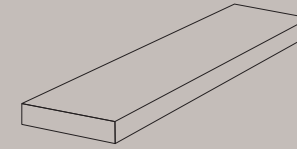

**SCALINO ANGOLARE INCOLLATO**  
GLUED CORNER STEP TREAD / CARREAU DE MARCHE COLLÉ  
PIÈCE ANGULAIRE / GEKLEBTE STUFENPLATTE ECKSTÜCK /  
PELDAÑO ESQUINA CON PERFIL PEGADO  
●◆ 33x120 (13"x48") RT 9 mm

## FORMATI

SIZES / FORMATS / FORMATE / FORMATOS

	120x278 (119,5x278)* 48"x110"	120x240 (119,5x239)* 48"x96"	120x120 (119,5x119,5)* 48"x48"	60x120 24"x48"	20x120 8"x48"	60x60 24"x24"	30x60 12"x24"
working size	1194x2778	1194x2390	1194x1194	596x1195	197x1195	596x596	297x596
	RT	RT	RT	RT	RT	RT	RT
	6 mm	9 mm	9 mm	9 mm	9 mm	9 mm	9 mm
<b>E. LUX CALACATTA</b>	◆	◆	◆	●◆	◆	●◆	●◆
<b>E. LUX SILVER GREY</b>	◆	◆	◆	●◆	◆	●◆	●◆
<b>E. LUX CALACATTA GOLD</b>	◆	◆	◆	●◆	◆	●◆	●◆
<b>E. LUX EMPERADOR</b>	◆			●◆	◆	●◆	●◆
<b>E. LUX LINCOLN</b>		◆	◆	●◆	◆	●◆	●◆
<b>E. LUX PORT LAURENT</b>	◆			●◆	◆	●◆	●◆
<b>E. LUX CREMA BEIGE</b>				●◆	◆	●◆	●◆

\*Formato nominale / Nominal size / Format nominal / Nennformat / Formato nominal

● Natural R9 | ◆ Lappato



# concrete & design

EFFECT

196 / Noord

204 / Ikon

212 / Moov

222 / Elements Design

NOORD GREY  
80x80 (32"x32")

---

# noord

**5**

COLORI/  
COLOURS  
COULEURS  
FARBE  
COLORES

**11**

FORMATI/  
SIZES  
FORMATS  
FORMATE  
FORMATOS

**2**

SUPERFICI/  
FINISHES  
FINITIONS  
OBERFLÄCHEN  
ACABADOS

**2**

SPESSORI/  
THICKNESS  
ÉPAISSEUR  
STÄRKE  
ESPESOR



NOORD TAUPE  
120x120 (48"x48")



NOORD GOLD  
120x120 (48"x48")

# 5

**COLORI/**  
COLOURS / COULEURS / FARBE / COLORES

NOORD GREY **V2**

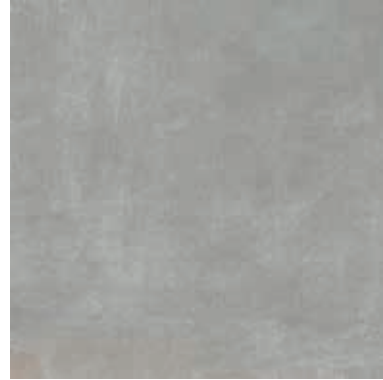

NOORD ANTHRACITE **V2**

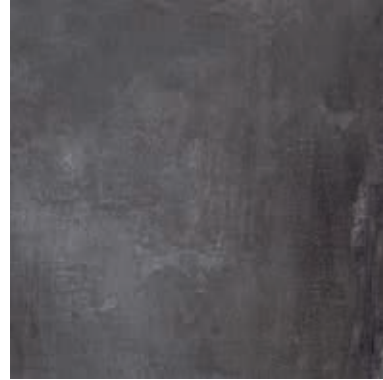

NOORD TAUPE **V2**



NOORD WHITE **V2**



NOORD GOLD **V2**



# 11

**FORMATI/**  
SIZES / FORMATS / FORMATE / FORMATOS



- 120x120 (48"x48") RT 9 mm
- ▲ 120x120 (48"x48") RT **K2** 20 mm

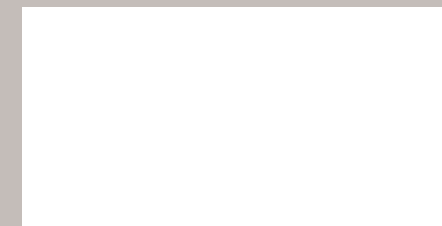

- 60x120 (24"x48") RT 9 mm



- 30x120 (12"x48") RT 9 mm

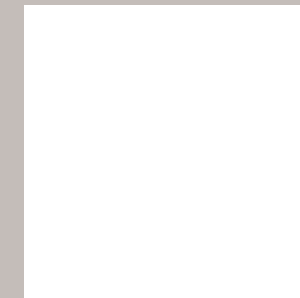

- 80x80 (32"x32") RT 9 mm
- ▲ 80x80 (32"x32") RT **K2** 20 mm

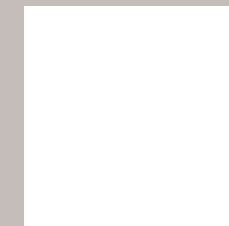

- 60x60 (24"x24") RT 9 mm
- ▲ 60x60 (24"x24") RT **K2** 20 mm



- 30x60 (12"x24") RT 9 mm
- ▲ 30x60 (12"x24") RT **K2** 20 mm



- 9,7x60 (3<sup>7/8</sup>"x24") RT 9 mm

- Natural R10 | ▲ Grip R11

# 3

## DECORI/

DECORS / PIECES SPECIALES / FORMTEILE /  
PIEZAS ESPECIALES

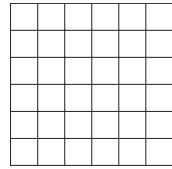

**MOSAICO** ● 30x30 (12"x12") RT 9 mm  
(TESSERE: 4,8x4,8 - 17/8"x17/8")



NOORD GREY

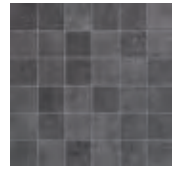

NOORD ANTHRACITE



NOORD TAUPE



NOORD WHITE



NOORD GOLD

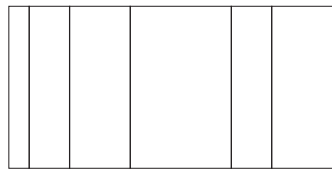

**DECORO DOCKS**  
● 30x60 (12"x24") RT 9 mm

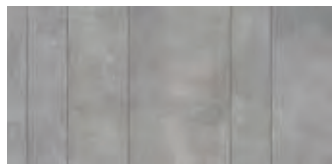

NOORD GREY

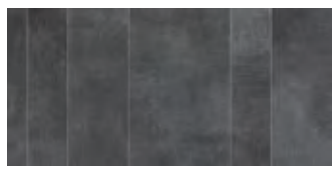

NOORD ANTHRACITE

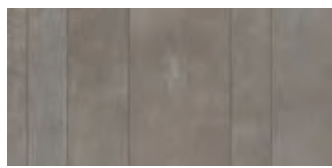

NOORD TAUPE



NOORD WHITE



NOORD GOLD



**LISTELLO UP** ● 9,7x60 (37/8"x24") RT 9 mm



NOORD GREY



NOORD ANTHRACITE



NOORD TAUPE



NOORD WHITE



NOORD GOLD

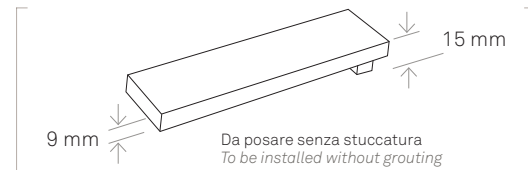

# 7

## PEZZI SPECIALI/

TRIMS / PIECES SPECIALES / FORMTEILE /  
PIEZAS ESPECIALES



**BATTISCOPA**  
BULLNOSE / PLINTHE / SOCKEL / RODAPIÉ  
● 4,6x120 (2<sup>13/16</sup>"x48") RT 9 mm  
● 7x80 (2<sup>3/4</sup>"x32") RT 9 mm  
● 7,2x60 (2,8"x24") RT 9 mm

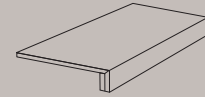

**SCALINO INCOLLATO**  
GLUED STEP TREAD / NEZ DE MARCHE COLLÉ  
GEKLEBTE STUFENPLATTE / PELDAÑO CON PERFIL PEGADO  
● 33x60 (13"x24") RT 9 mm



**SCALINO ANGOLARE INCOLLATO**  
GLUED CORNER STEP TREAD / CARREAU DE MARCHE COLLÉ  
PIÈCE ANGULAIRE / GEKLEBTE STUFENPLATTE ECKSTÜCK /  
PELDAÑO ESQUINA CON PERFIL PEGADO  
● 33x33 (13"x13") RT 9 mm

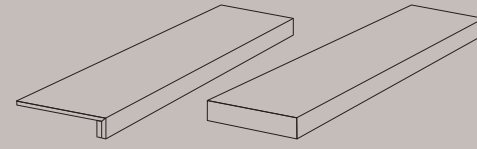

**SCALINO INCOLLATO**  
GLUED STEP TREAD / NEZ DE MARCHE COLLÉ  
GEKLEBTE STUFENPLATTE / PELDAÑO CON PERFIL PEGADO  
● 33x120 (13"x48") RT 9 mm

**SCALINO ANGOLARE INCOLLATO**  
GLUED CORNER STEP TREAD / CARREAU DE MARCHE COLLÉ  
PIÈCE ANGULAIRE / GEKLEBTE STUFENPLATTE ECKSTÜCK /  
PELDAÑO ESQUINA CON PERFIL PEGADO  
● 33x120 (13"x48") RT 9 mm

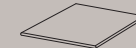

**ANGOLARE BORDO TORO**  
CORNER STEP TREAD / NEZ DE MARCHE ANGULAIRE /  
STUFENPLATTE ECKSTÜCK / ANGULAR CANTO ROMO  
▲ 40x40 (16"x16") RT 20 mm  
▲ 30x30 (12"x12") RT 20 mm



**GRADINO BORDO TORO**  
ROUNDED STEP TREAD / NEZ DE MARCHE ARRONDI /  
GERUNDET STUFENPLATTE / PELDAÑO CANTO ROMO  
▲ 60x120 (24"x48") RT 20 mm  
▲ 30x120 (12"x48") RT 20 mm  
▲ 40x80 (16"x32") RT 20 mm  
▲ 30x60 (12"x24") RT 20 mm

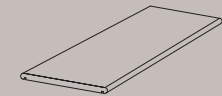

**TOP BORDO TORO**  
TOP STEP TREAD / NEZ DE MARCHE HAUT /  
STUFENPLATTE TOP / TOP CANTO ROMO  
▲ 30x60 (12"x24") RT 20 mm  
▲ 40x80 (16"x32") RT 20 mm

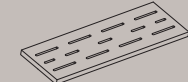

**GRIGLIA**  
GRID / GRIL / GRILL / REJILLA  
▲ 20x80 (8"x32") RT 20 mm  
▲ 15x60 (6"x24") RT 20 mm

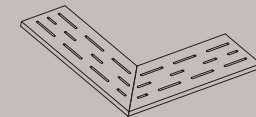

**ANGOLARE GRIGLIA**  
GRID / GRIL / GRILL / ANGULAR REJILLA  
▲ 20x80 (8"x32") RT 20 mm  
▲ 15x60 (6"x24") RT 20 mm

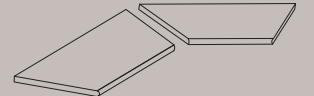

**ANGOLARE INTERNO BORDO TORO**  
INT. CORNER STEP TREAD / ANGLE INT. NEZ DE MARCHE /  
INNENECKTRITTSTUFE / ANG. INT. CANTO ROMO  
▲ 60x120 (24"x48") RT 20 mm  
▲ 30x120 (12"x48") RT 20 mm  
▲ 40x80 (16"x32") RT 20 mm  
▲ 30x60 (12"x24") RT 20 mm

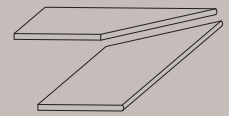

**ANGOLARE ESTERNO BORDO TORO**  
EXT. CORNER STEP TREAD / ANGLE EXT. NEZ DE MARCHE /  
AUSSENECKTRITTSTUFE / ANG. EXT. CANTO ROMO  
▲ 60x120 (24"x48") RT 20 mm  
▲ 30x120 (12"x48") RT 20 mm  
▲ 40x80 (16"x32") RT 20 mm  
▲ 30x60 (12"x24") RT 20 mm

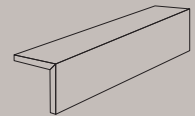

**CORDOLO L**  
GLUED "L" TERMINAL / TERMINAL "L" COLLÉ /  
"L" STÜCK FLIESE GEKLEBT / CANTONERA "L" (PEGADA)  
▲ 80x20x20 (32"x8"x8") RT 20 mm  
▲ 60x20x15 (24"x8"x6") RT 20 mm

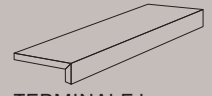

**TERMINALE L**  
GLUED "L" TERMINAL / TERMINAL "L" COLLÉ /  
"L" STÜCK FLIESE GEKLEBT / TERMINAL "L" (PEGADO)  
▲ 120x45x15 (48"x18"x6") RT 20 mm  
▲ 80x33x5 (32"x13"x2") RT 20 mm  
▲ 80x20x5 (13"x8"x2") RT 20 mm  
▲ 60x33x5 (24"x13"x2") RT 20 mm  
▲ 60x20x5 (24"x8"x2") RT 20 mm

## FORMATI

FORMATS / FORMATS / FORMATE / FORMATOS

	120x120 (119,5x119,5)* 48"x48"	60x120 24"x48"	30x120 12"x48"	80x80 32"x32"	60x60 24"x24"	30x60 12"x24"	9,7x60 37/8"x24"	120x120 (119,5x119,5)* 48"x48"	80x80 32"x32"	60x60 24"x24"	30x60 12"x24"
working size	1194x1194	596x1195	297x1195	795x795	596x596	297x596	97x596	1194x1194	795x795	596x596	297x596
	RT	RT	RT	RT	RT	RT	RT	RT	RT	RT	RT
	9 mm	9 mm	9 mm	9 mm	9 mm	9 mm	9 mm	20 mm	20 mm	20 mm	20 mm
<b>NOORD ANTHRACITE</b>	●	●	●	●	●	●	●		▲	▲	▲
<b>NOORD GREY</b>	●	●	●	●	●	●	●	▲	▲	▲	▲
<b>NOORD TAUPE</b>	●	●	●	●	●	●	●				
<b>NOORD GOLD</b>	●	●	●	●	●	●	●			▲	▲
<b>NOORD WHITE</b>	●	●	●	●	●	●	●	▲	▲	▲	▲

\*Formato nominale / Nominal size / Format nominal / Nennformat / Formato nominal

● Natural R10 | ▲ Grip R11

IKON SILVER  
120x120 (48"x48")

# ikon

**5**

COLORI/  
COLOURS  
COULEURS  
FARBE  
COLORES

**10**

FORMATI/  
SIZES  
FORMATS  
FORMATE  
FORMATOS

**3**

SUPERFICI/  
FINISHES  
FINITIONS  
OBERFLÄCHEN  
ACABADOS

**3**

SPESSORI/  
THICKNESS  
ÉPAISSEUR  
STÄRKE  
ESPESOR





IKON GREY  
120x120 (48"x48") - 120x278 (48"x110")



IKON WHITE  
60x120 (24"x48")



# 5

**COLORI/**  
COLOURS / COULEURS / FARBE / COLORES

IKON GREY V2

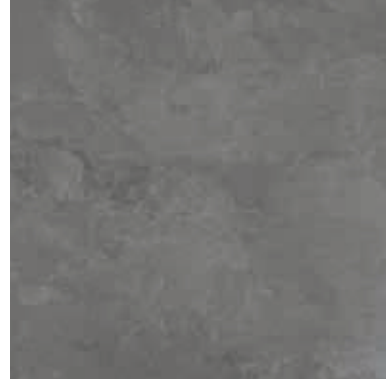

IKON SILVER V2



IKON SKY V2



IKON WHITE V2

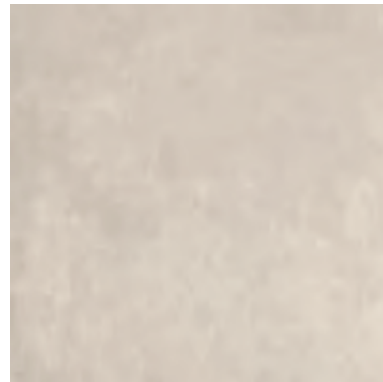

IKON BEIGE V2



# 10

**FORMATI/**  
SIZES / FORMATS / FORMATE / FORMATOS



● 120x278 (48"x110") RT 6 mm



● 120x120 (48"x48") RT 9 mm

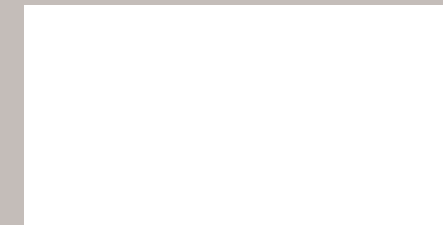

● 60x120 (24"x48") RT 9 mm



● 30x120 (12"x48") RT 9 mm



● 90x90 (36"x36") RT 9 mm  
▲ 90x90 (36"x36") RT K2 20 mm



▲ 30x60 (12"x24") RT 9 mm

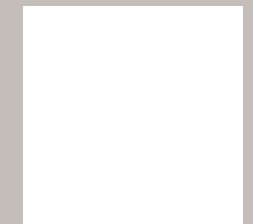

● 60x60 (24"x24") RT 9 mm  
▲ 60x60 (24"x24") RT K2 20 mm



■ 9,7x60 (3<sup>7/8</sup>"x24") RT 9 mm

● Natural R9 | ■ Grip R10 | ▲ Grip R11

# 2

## DECORI/

DECORS / PIECES SPECIALES / FORMTEILE /  
PIEZAS ESPECIALES

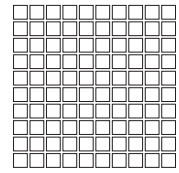

**MOSAICO ● 30x30 (12"x12") RT 9 mm**  
(TESSERE: 2,8x2,8 - 1<sup>1/8</sup>"x1<sup>1/8</sup>")



IKON GREY



IKON SILVER



IKON SKY

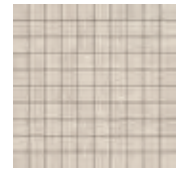

IKON WHITE



IKON BEIGE



**LISTELLO UP ■ 9,7x60 (3<sup>7/8</sup>"x24") RT 9 mm**



IKON GREY



IKON SILVER



IKON SKY



IKON WHITE



IKON BEIGE

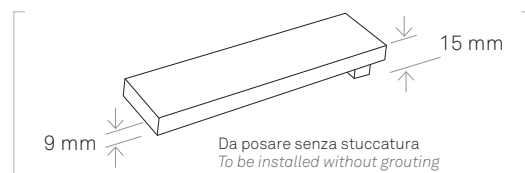

# 5

## PEZZI SPECIALI/

TRIMS / PIECES SPECIALES / FORMTEILE /  
PIEZAS ESPECIALES



**BATTISCOPA**  
BULLNOSE / PLINTHE / SOCKEL / RODAPIÉ  
● 7,2x60 (2.8"x24") RT 9 mm

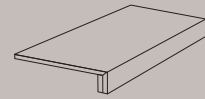

**SCALINO INCOLLATO**  
GLUED STEP TREAD / NEZ DE MARCHE COLLÉ / GEKLEBTE STUFENPLATTE  
STUFENPLATTE / PELDAÑO CON PERFIL PEGADO  
● ■ 33x60 (13"x24") RT 9 mm



**SCALINO ANGOLARE INCOLLATO**  
GLUED CORNER STEP TREAD / CARREAU DE MARCHE  
COLLÉ PIÈCE ANGULAIRE / GEKLEBTE STUFENPLATTE  
ECKSTÜCK / PELDAÑO ESQUINA CON PERFIL PEGADO  
● ■ 33x33 (13"x13") RT 9 mm

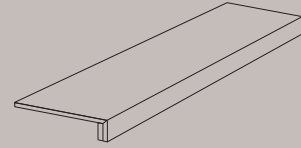

**SCALINO INCOLLATO**  
GLUED STEP TREAD / NEZ DE MARCHE COLLÉ / GEKLEBTE  
STUFENPLATTE / PELDAÑO CON PERFIL PEGADO  
● ■ 33x120 (13"x48") RT 9 mm

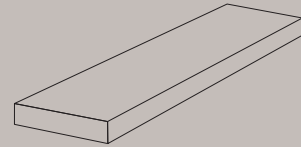

**SCALINO ANGOLARE INCOLLATO**  
GLUED CORNER STEP TREAD / CARREAU DE MARCHE  
COLLÉ PIÈCE ANGULAIRE / GEKLEBTE STUFENPLATTE  
ECKSTÜCK / PELDAÑO ESQUINA CON PERFIL PEGADO  
● ■ 33x120 (13"x48") RT 9 mm

# 10

## PEZZI SPECIALI K<sub>2</sub>/

TRIMS K<sub>2</sub> / PIECES SPECIALES K<sub>2</sub> / FORMTEILE K<sub>2</sub> /  
PIEZAS ESPECIALES K<sub>2</sub>

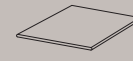

**ANGOLARE BORDO TORO**  
CORNER STEP TREAD / NEZ DE MARCHE ANGULAIRE /  
STUFENPLATTE ECKSTÜCK / ANGULAR CANTO ROMO  
▲ 30x30 (12"x12") RT 20 mm

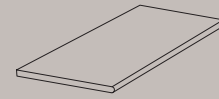

**GRADINO BORDO TORO**  
ROUNDED STEP TREAD / NEZ DE MARCHE ARRONDI /  
GERUNDET STUFENPLATTE / PELDAÑO CANTO ROMO  
▲ 30x60 (12"x24") RT 20 mm

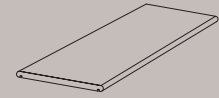

**TOP BORDO TORO**  
TOP STEP TREAD / NEZ DE MARCHE HAUT /  
STUFENPLATTE TOP / TOP CANTO ROMO  
▲ 30x60 (12"x24") RT 20 mm

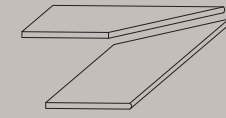

**ANGOLARE ESTERNO BORDO TORO**  
EXT. CORNER STEP TREAD / ANGLE EXT. NEZ DE MARCHE /  
AUSSENECKTRITTSTUFE / ANG. EXT. CANTO ROMO  
▲ 30x60 (12"x24") RT 20 mm

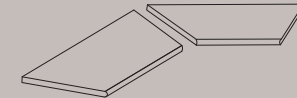

**ANGOLARE INTERNO BORDO TORO**  
INT. CORNER STEP TREAD / ANGLE INT. NEZ DE MARCHE /  
INNENECKTRITTSTUFE / ANG. INT. CANTO ROMO  
▲ 30x60 (12"x24") RT 20 mm

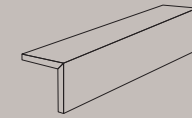

**CORDOLO L**  
GLUED "L" TERMINAL / TERMINAL "L" COLLÉ / "L"  
STÜCK FLIESE GEKLEBT / CANTONERA "L" (PEGADA)  
▲ 60x20x15 (24"x8"x6") RT 20 mm

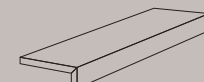

**TERMINALE L**  
GLUED "L" TERMINAL / TERMINAL "L" COLLÉ /  
"L" STÜCK FLIESE GEKLEBT / TERMINAL "L" (PEGADO)  
▲ 60x20x5 (24"x8"x2") RT 20 mm  
▲ 60x33x5 (13"x24"x2") RT 20 mm

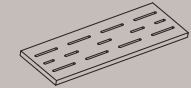

**GRIGLIA**  
GRID / GRIL / GRILL / REJILLA  
▲ 15x60 (6"x24") RT 20 mm

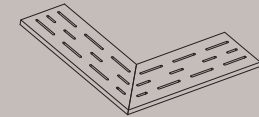

**ANGOLARE GRIGLIA**  
GRID / GRIL / GRILL / ANGULAR REJILLA  
▲ 15x60 (6"x24") RT 20 mm

## FORMATI

SIZES / FORMATS / FORMATE / FORMATOS

	120x278 (119,5x278)* 48"x110"	120x120 (119,5x119,5)* 48"x48"	60x120 24"x48"	30x120 12"x48"	90x90 36"x36"	60x60 24"x24"	30x60 12"x24"	9,7x60 30,9"x24"	90x90 36"x36"	60x60 24"x24"
working size	1194x2778	1194x1194	596x1195	297x1195	895x895	596x596	297x596	97x596	895x895	596x596
	RT	RT	RT	RT	RT	RT	RT	RT	RT	RT
	6 mm	9 mm	9 mm	9 mm	9 mm	9 mm	9 mm	9 mm	K <sub>2</sub> 20 mm	K <sub>2</sub> 20 mm
IKON GREY	●	● ■	● ■	● ■	●	● ■	■ ▲	■		
IKON SILVER	●	● ■	● ■	● ■	●	● ■	■ ▲	■	▲	▲
IKON WHITE	●	● ■	● ■	● ■	●	● ■	■ ▲	■	▲	▲
IKON SKY		● ■	● ■	● ■	●	● ■	■ ▲	■		
IKON BEIGE		● ■	● ■	● ■	●	● ■	■ ▲	■	▲	▲

\*Formato nominale / Nominal size / Format nominal / Nennformat / Formato nominal

● Natural R9 | ■ Grip R10 | ▲ Grip R11

MOOV GREY  
120x278 (48"x110") - 120x120 (48"x48")

---

# moov

5

COLORI/  
COLOURS  
COULEURS  
FARBE  
COLORES

19

FORMATI/  
SIZES  
FORMATS  
FORMATE  
FORMATOS

4

SUPERFICI/  
FINISHES  
FINITIONS  
OBERFLÄCHEN  
ACABADOS

5

SPESSORI/  
THICKNESS  
ÉPAISSEUR  
STÄRKE  
ESPEJOR



MOOV IVORY  
120x278 (48"x110") - 120x120 (48"x48")  
MOSAICO 30x30 (12"x12")

---

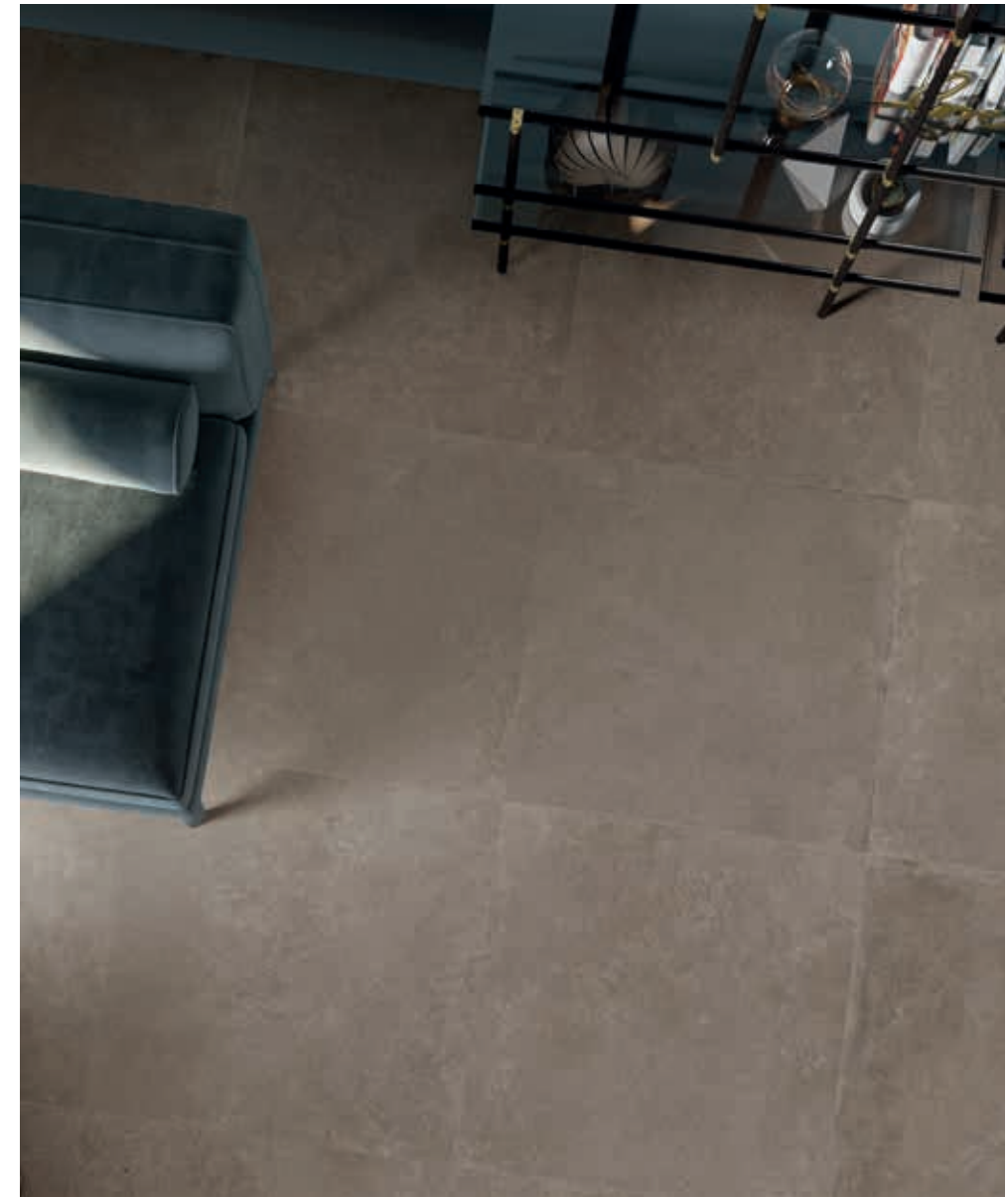

MOOV MOKA  
75x75 (30"x30")

---

# 5

## COLORI/

COLOURS / COULEURS / FARBE / COLORES

MOOV ANTHRACITE V2



MOOV GREY V2



MOOV MOKA V2



MOOV IVORY V2



MOOV BEIGE V2



# 19

## FORMATI/

SIZES / FORMATS / FORMATE / FORMATOS



● 120x278 (48"x110") RT 6 mm



● 120x240 (48"x96") RT 9 mm



● 120x120 (48"x48") RT 9 mm  
▲ 120x120 (48"x48") RT K2 20 mm

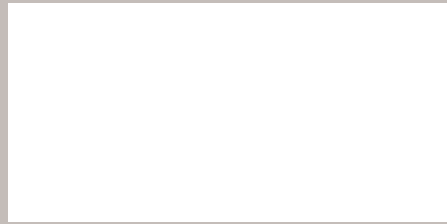

● ▲ 60x120 (24"x48") RT 9 mm



● 30x120 (12"x48") RT 9 mm



● 20x120 (8"x48") RT 9 mm

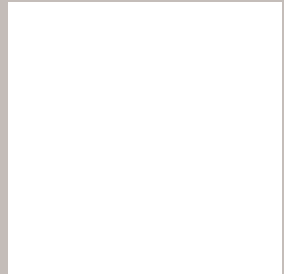

● 75x75 (30"x30") RT 9 mm

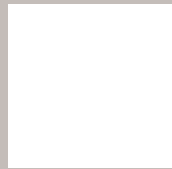

● 45x45 (18"x18") Not RT 9 mm



■ 7,5x30 (3"x12") Not RT 8,5 mm

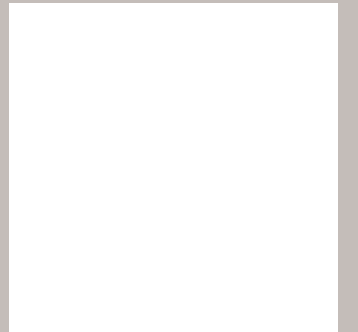

▲ 90x90 (36"x36") RT K2 20 mm



● ▲ 60x60 (24"x24") RT 9 mm  
▲ 60x60 (24"x24") RT K2 20 mm  
▲ 60x60 (24"x24") RT K3 30 mm



● ▲ 30x60 (12"x24") RT 9 mm



● 14,7x60 (5<sup>3</sup>/<sub>4</sub>"x24") RT 9 mm

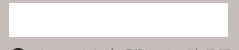

● 9,7x60 (3<sup>7</sup>/<sub>8</sub>"x24") RT 9 mm

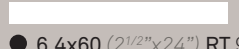

● 6,4x60 (2<sup>1</sup>/<sub>2</sub>"x24") RT 9 mm

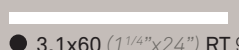

● 3,1x60 (1<sup>1</sup>/<sub>4</sub>"x24") RT 9 mm

● Natural R9 | ■ Structured R10 | ■ Grip R10 | ▲ Grip R11

# 3

## DECORI/

DECORS / PIECES SPECIALES / FORMTEILE /  
PIEZAS ESPECIALES

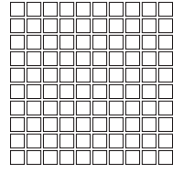

MOSAICO ● 30x30 (12"x12") RT 9 mm  
(TESSERE: 2,8x2,8 - 1 1/8"x1 1/8")



MOOV IVORY

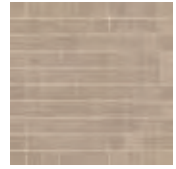

MOOV BEIGE



MOOV MOKA



MOOV ANTHRACITE



MOOV GREY



STRIPS ● 30x60 (12"x24") RT 9 mm



MOOV IVORY



MOOV BEIGE



MOOV MOKA



MOOV ANTHRACITE



MOOV GREY



LISTELLO UP ● 9,7x60 (3 7/8"x24") RT 9 mm



LISTELLO UP ● 6,4x60 (2 1/2"x24") RT 9 mm

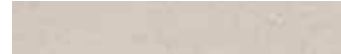

MOOV IVORY



MOOV BEIGE



MOOV BEIGE



MOOV MOKA



MOOV MOKA



MOOV ANTHRACITE



MOOV ANTHRACITE



MOOV GREY



MOOV GREY



MOOV GREY

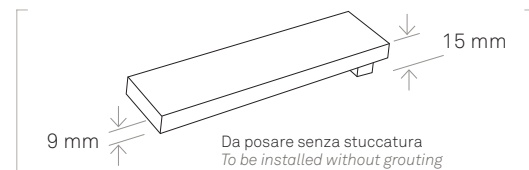

# BRIK ■ 7,5x30 (3"x12") Not RT 8,5 mm



BRIK MOOV IVORY



BRIK MOOV MOKA

# 8

## PEZZI SPECIALI/

TRIMS / PIECES SPECIALES / FORMTEILE /  
PIEZAS ESPECIALES



**BATTISCOPA**

BULLNOSE / PLINTHE / SOCKEL / RODAPIÉ

- 4,6x120 (1<sup>13/16</sup>"x48") RT 9 mm
- 7,2x75 (2.8"x30") RT 9 mm
- 7,2x60 (2.8"x24") RT 9 mm

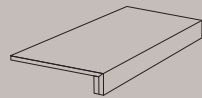

**SCALINO INCOLLATO**

GLUED STEP TREAD / NEZ DE MARCHE COLLÉ /  
GEKLEBTE STUFENPLATTE / PELDAÑO CON PERFIL PEGADO

- 33x60 (13"x24") RT 9 mm



**SCALINO ANGOLARE INCOLLATO**

GLUED CORNER STEP TREAD / CARREAU DE MARCHE COLLÉ  
PIÈCE ANGULAIRE / GEKLEBTE STUFENPLATTE ECKSTÜCK /  
PELDAÑO ESQUINA CON PERFIL PEGADO

- 33x33 (13"x13") RT 9 mm

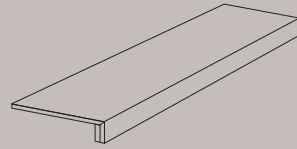

**SCALINO INCOLLATO**

GLUED STEP TREAD / NEZ DE MARCHE COLLÉ /  
GEKLEBTE STUFENPLATTE / PELDAÑO CON PERFIL PEGADO

- 33x120 (13"x48") RT 9 mm

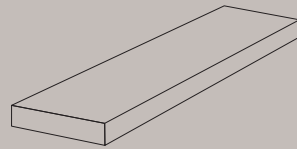

**SCALINO ANGOLARE INCOLLATO**

GLUED CORNER STEP TREAD / CARREAU DE MARCHE COLLÉ  
PIÈCE ANGULAIRE / GEKLEBTE STUFENPLATTE ECKSTÜCK /  
PELDAÑO ESQUINA CON PERFIL PEGADO

- 33x120 (13"x48") RT 9 mm



**TERMINALE L INCOLLATO**

GLUED L TERMINAL / TERMINALE ELLE COLLÉ /  
L STÜCK FLIESE GEKLEBT / REMATE EN FORMA DE L PEGADO

- 30x15x4 (12"x6"x1") RT 9 mm

# 10

## PEZZI SPECIALI K<sub>2</sub>/

TRIMS K<sub>2</sub> / PIECES SPECIALES K<sub>2</sub> / FORMTEILE K<sub>2</sub> /  
PIEZAS ESPECIALES K<sub>2</sub>

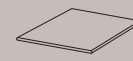

**ANGOLARE BORDO TORO**

CORNER STEP TREAD / NEZ DE MARCHE ANGULAIRE /  
STUFENPLATTE ECKSTÜCK / ANGULAR CANTO ROMO

- ▲ 30x30 (12"x12") RT 20 mm

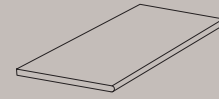

**GRADINO BORDO TORO**

ROUNDED STEP TREAD / NEZ DE MARCHE ARRONDI /  
GERUNDET STUFENPLATTE / PELDAÑO CANTO ROMO

- ▲ 30x60 (12"x24") RT 20 mm

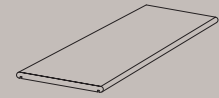

**TOP BORDO TORO**

TOP STEP TREAD / NEZ DE MARCHE HAUT /  
STUFENPLATTE TOP / TOP CANTO ROMO

- ▲ 30x60 (12"x24") RT 20 mm

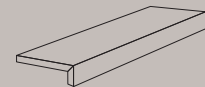

**TERMINALE L**

GLUED "L" TERMINAL / TERMINAL "L" COLLÉ /  
"L" STÜCK FLIESE GEKLEBT / TERMINAL "L" (PEGADO)

- ▲ 60x20x5 (24"x8"x2") RT 20 mm
- ▲ 60x33x5 (13"x24"x2") RT 20 mm

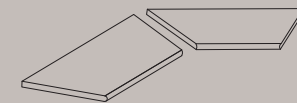

**ANGOLARE INTERNO BORDO TORO**

INT. CORNER STEP TREAD / ANGLE INT. NEZ DE MARCHE /  
INNENECKTRITTSTUFE / ANG. INT. CANTO ROMO

- ▲ 30x60 (12"x24") RT 20 mm

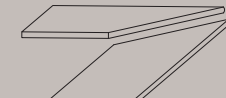

**ANGOLARE ESTERNO BORDO TORO**

EXT. CORNER STEP TREAD / ANGLE EXT. NEZ DE MARCHE /  
AUSSENECKTRITTSTUFE / ANG. EXT. CANTO ROMO

- ▲ 30x60 (12"x24") RT 20 mm

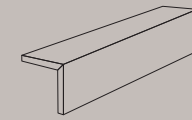

**CORDOLO L**

GLUED "L" TERMINAL / TERMINAL "L" COLLÉ /  
"L" STÜCK FLIESE GEKLEBT / CANTONERA "L" (PEGADA)

- ▲ 60x20x15 (24"x8"x6") RT 20 mm

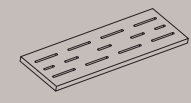

**GRIGLIA**

GRID / GRIL / GRILL / REJILLA

- ▲ 15x60 (6"x24") RT 20 mm

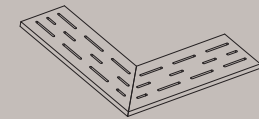

**ANGOLARE GRIGLIA**

GRID / GRIL / GRILL / ANGULAR REJILLA

- ▲ 15x60 (6"x24") RT 20 mm

## FORMATI

FORMATS / FORMATS / FORMATE / FORMATOS

	120x278 (119,5x278)* 48"x110"	120x240 (119,5x239)* 48"x96"	120x120 (119,5x119,5)* 48"x48"	60x120 24"x48"	30x120 12"x48"	20x120 8"x48"	75x75 30"x30"	60x60 24"x24"	30x60 12"x24"	14,7x60 5 <sup>3/4</sup> "x24"	9,7x60 3 <sup>7/8</sup> "x24"	6,4x60 3 <sup>1/2</sup> "x24"	3,1x60 1 <sup>1/4</sup> "x24"	45x45 18"x18"	7,5x30 3"x12"	120x120 (119,5x119,5)* 48"x48"	90x90 36"x36"	60x60 24"x24"	60x60 24"x24"
working size	1194x2778	1194x2390	1194x1194	596x1195	297x1195	197x1195	748x748	596x596	297x596	147x596	97x596	64x596	31x596	9 mm	8,5 mm	1194x1194	895x895	596x596	596x596
	RT	RT	RT	RT	RT	RT	RT	RT	RT	RT	RT	RT	RT	9 mm	8,5 mm	RT	RT	RT	RT
	6 mm	9 mm	9 mm	9 mm	9 mm	9 mm	9 mm	9 mm	9 mm	9 mm	9 mm	9 mm	9 mm	9 mm	8,5 mm	K2 20 mm	K2 20 mm	K2 20 mm	K3 30 mm
MOOV GREY	●	●	●■	●■▲	●	●	●	●■▲	●■▲	●	●	●	●	●		▲	▲	▲	▲
MOOV ANTHRACITE		●	●■	●■▲	●	●	●	●■▲	●■▲	●	●	●	●	●		▲	▲	▲	
MOOV MOKA		●	●■	●■▲	●	●	●	●■▲	●■▲	●	●	●	●	●	■	▲	▲	▲	▲
MOOV BEIGE		●	●■	●■▲	●	●	●	●■▲	●■▲	●	●	●	●	●			▲	▲	
MOOV IVORY	●	●	●■	●■▲	●	●	●	●■▲	●■▲	●	●	●	●	●	■				

\*Formato nominale / Nominal size / Format nominal / Nennformat / Formato nominal

● Natural R9 | ■ Structured R10 | ■ Grip R10 | ▲ Grip R11



ELEMENTS DESIGN BEIGE  
120x278 (48"x110") - 120x120 (48"x48")

# elements design

7

COLORI/  
COLOURS  
COULEURS  
FARBE  
COLORES

10

FORMATI/  
SIZES  
FORMATS  
FORMATE  
FORMATOS

5

SUPERFICI/  
FINISHES  
FINITIONS  
OBERFLÄCHEN  
ACABADOS

4

SPESSORI/  
THICKNESS  
ÉPAISSEUR  
STÄRKE  
ESPESOR





ELEMENTS DESIGN BLACK  
120x120 (48"x48")

E. LUX CALACATTA  
120x240 (48"x96")

ELEMENTS DESIGN TAUPE  
120x120 (48"x48") -  
MOSAICO ROMBI COLD 30,5x35,2 (12<sup>1/16</sup>"x13<sup>7/8</sup>"

# 7

**COLORI/**  
COLOURS / COULEURS / FARBE / COLORES

E. DESIGN IVORY V1



E. DESIGN BEIGE V1



E. DESIGN BLACK V1



LEED  
COMPLIANT

E. DESIGN TAUPE V1



E. DESIGN WHITE V1

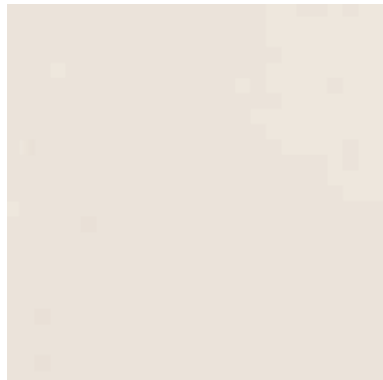

E. DESIGN SILVER V1



E. DESIGN GREY V1

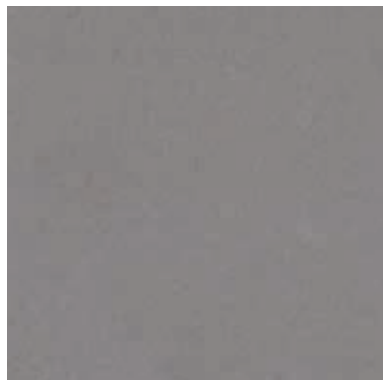

LEED  
COMPLIANT

# 10

**FORMATI/**  
SIZES / FORMATS / FORMATE / FORMATOS

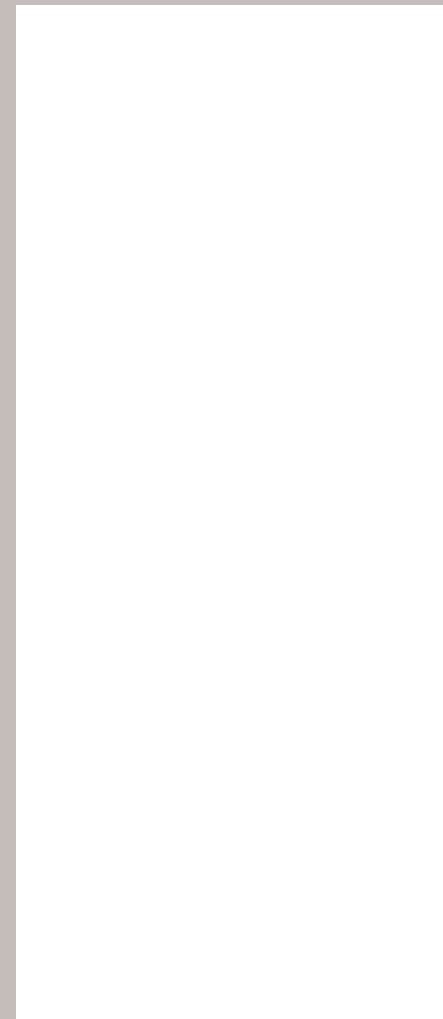

● 120x278 (48"x110") RT 6 mm



● 120x120 (48"x48") RT 9 mm

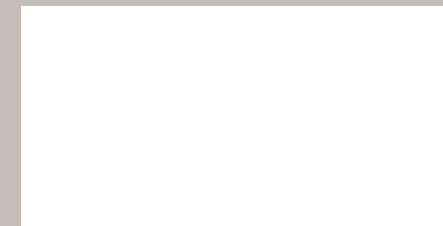

●◆ 60x120 (24"x48") RT 9 mm  
▲ 60x120 (24"x48") RT K2 20 mm



● 20x120 (8"x48") RT 9 mm



●◆ 60x60 (24"x24") RT 9 mm



●■ 30x60 (12"x24") RT 9 mm



● 25x21,6 (10"x8<sup>5/8</sup>") Not RT 9 mm



● 9,7x60 (3<sup>7/8</sup>"x24") RT 9 mm



★ 7,5x30 (3"x12") Not RT 8,5 mm

● Natural | ● Natural R9 | ■ Structured R10 | ▲ Structured R11 | ◆ Lappato | ★ Glossy

# 4

## DECORI/

DECORS / PIECES SPECIALES / FORMTEILE /  
PIEZAS ESPECIALES

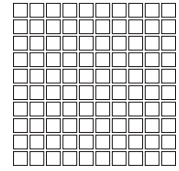

**MOSAICO ● 30x30 (12"x12") RT 9 mm**  
(TESSERE: 2,8x2,8 - 1 1/8"x1 1/8")



IVORY



BEIGE



TAUPE



WHITE



SILVER



GREY

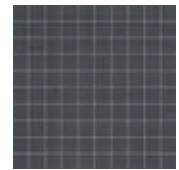

BLACK



**CHEVRON DX ● 10x59 (4"x24") RT 9 mm**



**CHEVRON SX ● 10x59 (4"x24") RT 9 mm**



IVORY



BEIGE



TAUPE



WHITE



SILVER



GREY



BLACK

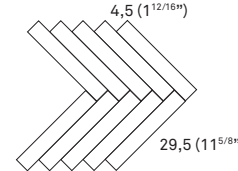

**MOSAICO HERRINGBONE**  
**● 34,5x42 (13 9/16"x16 9/16") RT 9 mm**



IVORY



BEIGE



TAUPE



WHITE



SILVER



GREY



BLACK

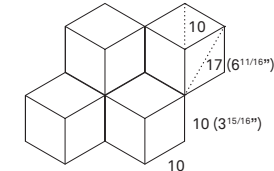

**MOSAICO ROMBI**  
**● 30,5x35,2 (12 1/16"x13 7/8") RT 9 mm**



COLD (BLACK - GREY - SILVER)



WARM (GREY - BEIGE - IVORY)

# GLOSSY

★ 7,5x30 (3"x12") Not RT 8,5 mm



ELEMENTS DESIGN IVORY GLOSSY



ELEMENTS DESIGN BEIGE GLOSSY



ELEMENTS DESIGN TAUPE GLOSSY



ELEMENTS DESIGN WHITE GLOSSY



ELEMENTS DESIGN SILVER GLOSSY



ELEMENTS DESIGN GREY GLOSSY



ELEMENTS DESIGN BLACK GLOSSY

## 5 PEZZI SPECIALI/

TRIMS / PIECES SPECIALES / FORMTEILE /  
PIEZAS ESPECIALES



**BATTISCOPA**  
BULLNOSE / PLINTHE / SOCKEL / RODAPIÉ  
● 7,2x60 (2,8"x24") RT 9mm

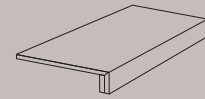

**SCALINO INCOLLATO**  
GLUED STEP TREAD / NEZ DE MARCHE COLLÉ /  
GEKLEBTE STUFENPLATTE / PELDAÑO CON PERFIL PEGADO  
●■ 33x60 (13"x24") RT 9mm



**SCALINO ANGOLARE INCOLLATO**  
GLUED CORNER STEP TREAD / CARREAU DE MARCHE  
COLLÉ PIÈCE ANGULAIRE / GEKLEBTE STUFENPLATTE  
ECKSTÜCK / PELDAÑO ESQUINA CON PERFIL PEGADO  
●■ 33x33 (13"x13") RT 9mm

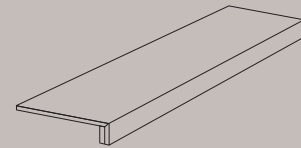

**SCALINO INCOLLATO**  
GLUED STEP TREAD / NEZ DE MARCHE COLLÉ /  
GEKLEBTE STUFENPLATTE / PELDAÑO CON PERFIL PEGADO  
●■ 33x120 (13"x48") RT 9 mm

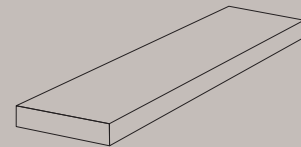

**SCALINO ANGOLARE INCOLLATO**  
GLUED CORNER STEP TREAD / CARREAU DE MARCHE COLLÉ  
PIÈCE ANGULAIRE / GEKLEBTE STUFENPLATTE  
ECKSTÜCK / PELDAÑO ESQUINA CON PERFIL PEGADO  
●■ 33x120 (13"x48") RT 9 mm

● Natural R9 | ■ Structured R10

## 9 PEZZI SPECIALI K<sub>2</sub>/

TRIMS K<sub>2</sub> / PIECES SPECIALES K<sub>2</sub> / FORMTEILE K<sub>2</sub> /  
PIEZAS ESPECIALES K<sub>2</sub>



**GRADINO BORDO TORO**  
ROUNDED STEP TREAD / NEZ DE MARCHE ARRONDI /  
GERUNDET STUFENPLATTE / PELDAÑO CANTO ROMO  
▲ 60x120 (24"x48") RT 20 mm  
▲ 30x120 (12"x48") RT 20 mm



**GRIGLIA**  
GRID / GRIL / GRILL / REJILLA  
▲ 15x60 (6"x24") RT 20 mm

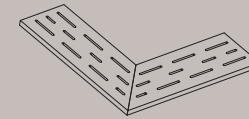

**ANGOLARE GRIGLIA**  
GRID / GRIL / GRILL / ANGULAR REJILLA  
▲ 15x60 (6"x24") RT 20 mm

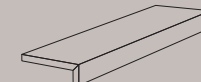

**TERMINALE L**  
GLUED "L" TERMINAL / TERMINAL "L" COLLÉ /  
"L" STÜCK FLIESE GEKLEBT / TERMINAL "L" (PEGADO)  
▲ 120x45x15 (48"x18"x6") RT 20 mm

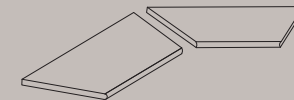

**ANGOLARE INTERNO BORDO TORO**  
INT. CORNER STEP TREAD / ANGLE INT. NEZ DE MARCHE /  
INNENECKTRITTSTUFE / ANG. INT. CANTO ROMO  
▲ 60x120 (24"x48") RT 20 mm  
▲ 30x120 (12"x48") RT 20 mm

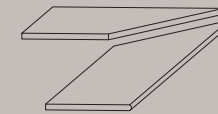

**ANGOLARE ESTERNO BORDO TORO**  
EXT. CORNER STEP TREAD / ANGLE EXT. NEZ DE MARCHE /  
AUSSENECKTRITTSTUFE / ANG. EXT. CANTO ROMO  
▲ 60x120 (24"x48") RT 20 mm  
▲ 30x120 (12"x48") RT 20 mm

### FORMATI

FORMATS / FORMATS / FORMATE / FORMATOS

	120x278 (119,5x278)* 48"x110"	120x120 (119,5x119,5)* 48"x48"	60x120 24"x48"	20x120 8"x48"	60x60 24"x24"	30x60 12"x24"	9,7x60 3 <sup>7/8</sup> "x24"	60x120 24"x48"	25x21,6 10"x8 <sup>3/8</sup> " esagona	7,5x30 3"x12"
working size	1194x2778	1194x1194	596x1195	197x1195	596x596	297x596	97x596	596x1195		
	RT	RT	RT	RT	RT	RT	RT	RT	Not RT	Not RT
	6 mm	9 mm	9 mm	9 mm	9 mm	9 mm	9 mm	K <sub>2</sub> 20 mm	9 mm	8,5 mm
E.DESIGN IVORY	●	●■	●	●	●■	●■	●		●	★
E.DESIGN BEIGE	●	●	●■◆	●	●■◆	●■	●	▲	●	★
E.DESIGN TAUPE		●	●■	●	●■	●■	●		●	★
E.DESIGN WHITE	●	●	●■◆	●	●■◆	●■	●	▲	●	★
E.DESIGN SILVER		●	●■	●	●■	●■	●		●	★
E.DESIGN GREY	●	●	●■◆	●	●■◆	●■	●	▲	●	★
E.DESIGN BLACK		●	●■	●	●■	●■	●		●	★

\*Formato nominale / Nominal size / Format nominal / Nennformat / Formato nominal

● Natural | ● Natural R9  
■ Structured R10 | ▲ Structured R11 | ★ Glossy | ◆ Lappato



# wood

EFFECT

234 / Beat

242 / Evoke

250 / Soul

BEAT BROWN  
20x120 (8"x48")

---

# beat

5

COLORI/  
COLOURS  
COULEURS  
FARBE  
COLORES

4

FORMATI/  
SIZES  
FORMATS  
FORMATE  
FORMATOS

3

SUPERFICI/  
FINISHES  
FINITIONS  
OBERFLÄCHEN  
ACABADOS

2

SPESSORI/  
THICKNESS  
ÉPAISSEUR  
STÄRKE  
ESPEJOR





BEAT TAUPE  
20x120 (8"x48")

---



BEAT GREY  
20x120 (8"x48") -  
DECORO IDRO BEAT CELL 70x80 (29<sup>9</sup>/<sub>16</sub>"x31<sup>1</sup>/<sub>2</sub>" )

---

wood effect | beat



# 5

**COLORI/**  
COLOURS / COULEURS / FARBE / COLORES

BEAT BROWN V2



BEAT IVORY V2



BEAT GREY V2



BEAT TAUPE V2



LEED  
COMPLIANT

BEAT WALNUT V2



# 4

**FORMATI/**  
SIZES / FORMATS / FORMATE / FORMATOS



● 30x240 (12"x96") RT 9 mm

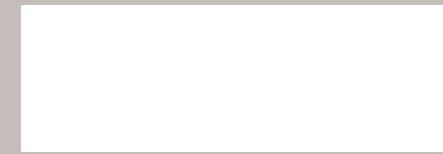

▲ 40x120 (16"x48") RT K2 20 mm

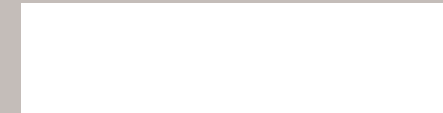

● 30x120 (12"x48") RT 9 mm



● ■ 20x120 (8"x48") RT 9 mm

● Natural R9 | ■ Grip R10 | ▲ Structured R11

# 3

## DECORI/

DECORS / PIECES SPECIALES / FORMTEILE /  
PIEZAS ESPECIALES

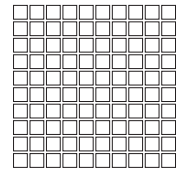

**MOSAICO ● 30x30 (12"x12") RT 9 mm**  
(TESSERE: 2,8x2,8 - 11/6"x11/6")



BEAT BROWN



BEAT IVORY



BEAT GREY



BEAT TAUPE



BEAT WALNUT

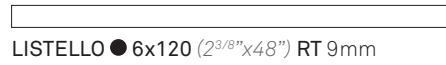

**LISTELLO ● 6x120 (2<sup>3</sup>/<sub>8</sub>"x48") RT 9mm**



**LISTELLO ● 3x120 (1<sup>3</sup>/<sub>16</sub>"x48") RT 9 mm**



BEAT BROWN



BEAT BROWN



BEAT IVORY



BEAT IVORY



BEAT GREY



BEAT GREY



BEAT TAUPE



BEAT TAUPE



BEAT WALNUT



BEAT WALNUT

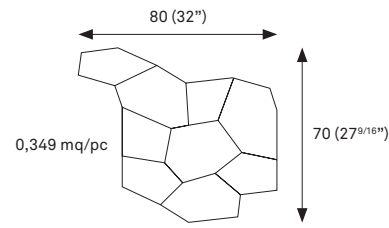

**DECORO IDRO BEAT CELL**  
**● 70x80 (27<sup>9</sup>/<sub>16</sub>"x32") RT 9 mm**



BEAT BROWN



BEAT IVORY



BEAT GREY



BEAT TAUPE



BEAT WALNUT

# 3

## PEZZI SPECIALI/

TRIMS / PIECES SPECIALES / FORMTEILE /  
PIEZAS ESPECIALES



**BATTISCOPIA**  
BULLNOSE / PLINTHE / SOCKEL / RODAPIÉ  
**● 6,2x60 (2.4"x24") RT 9 mm**

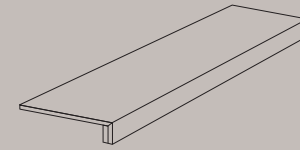

**SCALINO CON PROFILO INCOLLATO**  
GLUED STEP TREAD / NEZ DE MARCHE COLLÉ /  
GEKLEBTE STUFENPLATTE / PELDAÑO CON PERFIL PEGADO  
**● 30x120 (12"x48") RT 9 mm**

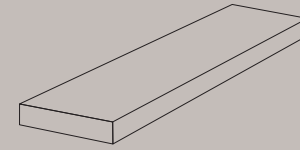

**SCALINO ANGOLARE INCOLLATO**  
GLUED CORNER STEP TREAD / CARREAU DE MARCHE COLLÉ  
PIÈCE ANGULAIRE / GEKLEBTE STUFENPLATTE ECKSTÜCK /  
PELDAÑO ESQUINA CON PERFIL PEGADO  
**● 30x120 (12"x48") RT 9 mm**

# 1

## PEZZI SPECIALI K<sub>2</sub>/

TRIMS K<sub>2</sub> / PIECES SPECIALES K<sub>2</sub> /  
FORMTEILE K<sub>2</sub> / PIEZAS ESPECIALES K<sub>2</sub>

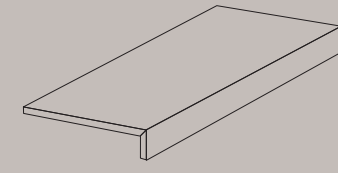

**TERMINALE L**  
GLUED L TERMINAL / TERMINALE ELLE COLLÉ / L STÜCK  
FLIESE GEKLEBT / REMATE EN FORMA DE L PEGADO  
**▲ 120x40x10 (48"x18"x4") RT 20 mm**

## FORMATI

SIZES / FORMATS / FORMATE / FORMATOS

	30x240 (30x239)* 12"x96"	30x120 12"x48"	20x120 8"x48"	40x120 16"x48"
working size	297x2390	297x1195	197x1195	397x1195
	RT	RT	RT	RT
	9 mm	9 mm	9 mm	<b>K2</b> 20 mm
<b>BEAT BROWN</b>		●	●■	
<b>BEAT IVORY</b>		●	●■	
<b>BEAT GREY</b>	●	●	●■	▲
<b>BEAT TAUPE</b>		●	●■	
<b>BEAT WALNUT</b>	●	●	●■	▲

\*Formato nominale / Nominal size / Format nominal / Nennformat / Formato nominal

● Natural R9 | ■ Grip R10 | ▲ Structured R11

# evoke

EVOKE BEIGE  
20x120 (8"x48")

---

**5**

COLORI/  
COLOURS  
COULEURS  
FARBE  
COLORES

**4**

FORMATI/  
SIZES  
FORMATS  
FORMATE  
FORMATOS

**2**

SUPERFICI/  
FINISHES  
FINITIONS  
OBERFLÄCHEN  
ACABADOS

**2**

SPESSORI/  
THICKNESS  
ÉPAISSEUR  
STÄRKE  
ESPESOR





EVOKE IVORY  
20x120 (8"x48") - 30x120 (12"x48")

---

EVOKE BROWN  
30x120 (12"x48") - 20x120 (8"x48") -  
15x20 (6"x48") - 30x120 (12"x48") K2 20mm

---

# 5

**COLORI/**  
COLOURS / COULEURS / FARBE / COLORES

EVOKE IVORY **V2**



EVOKE BEIGE **V2**



EVOKE SAND **V2**

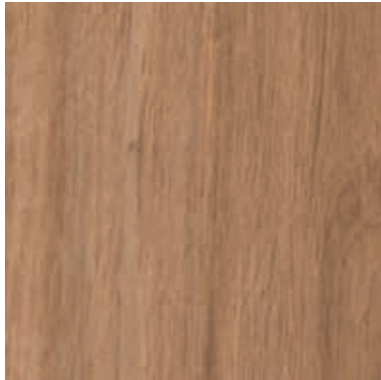

EVOKE BROWN **V2**



EVOKE MOKA **V2**

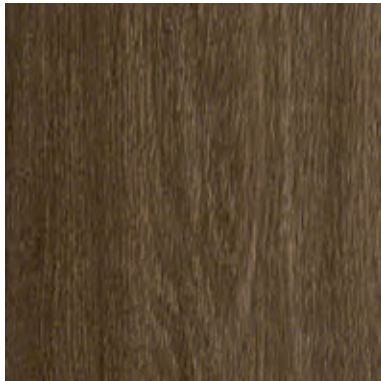

# 4

**FORMATI/**  
SIZES / FORMATS / FORMATE / FORMATOS



- 30x120 (12"x48") RT 9 mm
- ▲ 30x120 (12"x48") RT **K2** 20 mm



- ▲ 20x120 (8"x48") RT 9 mm



- 15x120 (6"x48") RT 9 mm

- Natural R9 | ▲ Structured R11

# 1 DECORO/

DECORS / PIECES SPECIALES / FORMTEILE /  
PIEZAS ESPECIALES



LISTELLO ● 6x120 (2 1/2"x48") RT 9 mm

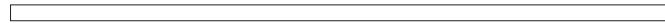

LISTELLO ● 3x120 (1 1/4"x48") RT 9 mm



EVOKE IVORY



EVOKE IVORY



EVOKE BEIGE



EVOKE BEIGE



EVOKE SAND



EVOKE SAND



EVOKE BROWN



EVOKE BROWN



EVOKE MOKA



EVOKE MOKA

# 3 PEZZI SPECIALI/

TRIMS / PIECES SPECIALES / FORMTEILE /  
PIEZAS ESPECIALES



BATTISCOPA  
BULLNOSE / PLINTHE / SOCKEL / RODAPIÉ  
● 7,2x60 (2,8"x24") RT 9 mm

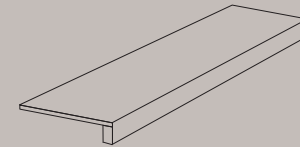

SCALINO INCOLLATO  
GLUED STEP TREAD / NEZ DE MARCHE COLLÉ /  
GEKLEBTE STUFENPLATTE / PELDAÑO CON PERFIL PEGADO  
● 30x120 (12"x48") RT 9 mm

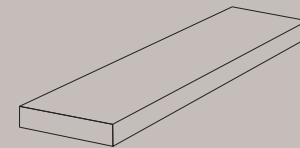

SCALINO ANGOLARE INCOLLATO  
GLUED CORNER STEP TREAD / CARREAU DE MARCHE COLLÉ  
PIÈCE ANGULAIRE / GEKLEBTE STUFENPLATTE ECKSTÜCK /  
PELDAÑO ESQUINA CON PERFIL PEGADO  
● 30x120 (12"x48") RT 9 mm

# 3 PEZZI SPECIALI K<sub>2</sub>/

TRIMS K<sub>2</sub> / PIECES SPECIALES K<sub>2</sub> / FORMTEILE K<sub>2</sub> /  
PIEZAS ESPECIALES K<sub>2</sub>

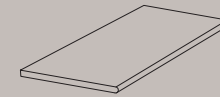

GRADINO BORDO TORO  
ROUNDED STEP TREAD / NEZ DE MARCHE ARRONDI /  
GERUNDET STUFENPLATTE / PELDAÑO CANTO ROMO  
▲ 30x120 (12"x48") RT 20 mm

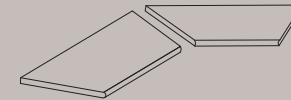

ANGOLARE INTERNO BORDO TORO  
INT. CORNER STEP TREAD / ANGLE INT. NEZ DE MARCHE /  
INNENECKTRITTSTUFE / ANG. INT. CANTO ROMO  
▲ 30x120 (12"x48") RT 20 mm

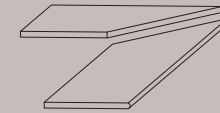

ANGOLARE ESTERNO BORDO TORO  
EXT. CORNER STEP TREAD / ANGLE EXT. NEZ DE MARCHE /  
AUSSENECKTRITTSTUFE / ANG. EXT. CANTO ROMO  
▲ 30x120 (12"x48") RT 20 mm

## FORMATI

FORMATS / FORMATS / FORMATE / FORMATOS

	30x120 12"x48"	20x120 8"x48"	15x120 6"x48"	30x120 12"x48"
working size	297x1195	197x1195	147x1195	297x1195
	RT	RT	RT	RT
	9 mm	9 mm	9 mm	K <sub>2</sub> 20 mm
EVOKE IVORY	●	●▲	●	
EVOKE SAND	●	●	●	▲
EVOKE BEIGE	●	●▲	●	
EVOKE BROWN	●	●	●	▲
EVOKE MOKA	●	●▲	●	

\*Formato nominale / Nominal size / Format nominal / Nennformat / Formato nominal

● Natural R9 | ▲ Structured R11

# soul

SOUL WALNUT  
30x120 (12"x48") K2 20 mm

---

**3**

COLORI/  
COLOURS  
COULEURS  
FARBE  
COLORES

**1**

FORMATI/  
SIZES  
FORMATS  
FORMATE  
FORMATOS

**1**

SUPERFICI/  
FINISHES  
FINITIONS  
OBERFLÄCHEN  
ACABADOS

**1**

SPESSORI/  
THICKNESS  
ÉPAISSEUR  
STÄRKE  
ESPESOR



# 3

## COLORI/

COLOURS / COULEURS / FARBE / COLORES

SOUL GREY V3



SOUL BLEND V4



SOUL WALNUT V2



# 1

## FORMATI/

SIZES / FORMATS / FORMATE / FORMATOS



▲ 30x120 (12"x48") RT K2 20 mm

# 3

## PEZZI SPECIALI K2/

TRIMS K2 / PIECES SPECIALES K2 / FORMTEILE K2 / PIEZAS ESPECIALES K2

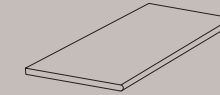

GRADINO BORDO TORO

ROUNDED STEP TREAD / NEZ DE MARCHE ARRONDI / GERUNDET STUFENPLATTE / PELDAÑO CANTO ROMO

▲ 30x120 (12"x48") RT 20 mm

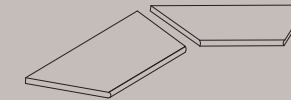

ANGOLARE INTERNO BORDO TORO

INT. CORNER STEP TREAD / ANGLE INT. NEZ DE MARCHE / INNENECKTRITTSTUFE / ANG. INT. CANTO ROMO

▲ 30x120 (12"x48") RT 20 mm

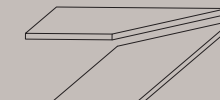

ANGOLARE ESTERNO BORDO TORO

EXT. CORNER STEP TREAD / ANGLE EXT. NEZ DE MARCHE / AUSSENECKTRITTSTUFE / ANG. EXT. CANTO ROMO

▲ 30x120 (12"x48") RT 20 mm

## FORMATI

FORMATS / FORMATS / FORMATE / FORMATOS

	30x120 12"x48"
working size	297x1195
	RT
	K2 20 mm
SOUL BLEND	▲
SOUL WALNUT	▲
SOUL GREY	▲

\*Formato nominale / Nominal size / Format nominal / Nennformat / Formato nominal

▲ Structured R11





# colour

EFFECT

256 / K-Color

260 / Granigliati - Linea Tecnica

# k-color

SPRING 20x20 (8"x8")  
MINT 20x20 (8"x8")

---

**21**

COLORI/  
COLOURS  
COULEURS  
FARBE  
COLORES

**1**

FORMATI/  
SIZES  
FORMATS  
FORMATE  
FORMATOS

**2**

SUPERFICI/  
FINISHES  
FINITIONS  
OBERFLÄCHEN  
ACABADOS

**1**

SPESSORI/  
THICKNESS  
ÉPAISSEUR  
STÄRKE  
ESPEJOR



# 21

COLORI/  
COLOURS / COULEURS / FARBE / COLORES



# 1

FORMATO/  
SIZES / FORMATS / FORMATE / FORMATOS

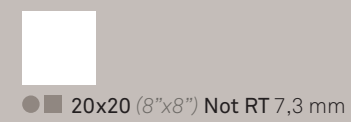

# 5

PEZZI SPECIALI/  
TRIMS / PIECES SPECIALES / FORMTEILE /  
PIEZAS ESPECIALES

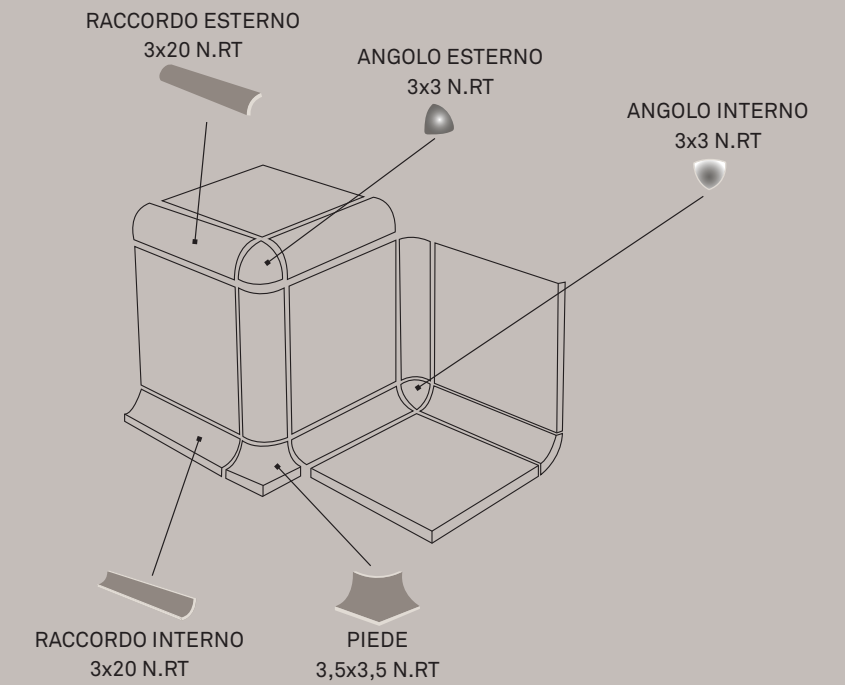

## FORMATI

FORMATS / FORMATS / FORMATE / FORMATOS

	20x20 8"x8"		20x20 8"x8"	
	Not RT		Not RT	
	7,3 mm		7,3 mm	
NIGHT	●		●	
GREYNESS	●		●	
URBAN	●■		●	
PEARL	●		●	
WHITE	●■		●	
SKY	●		●	
CRYSTAL	●■		●	
NAVY	●		●	
MINT	●■		●	
SPRING	●		●	
IVORY	●■		●	
CAMEL		●		●
ECRU		●		●
MOON		●		●
BROWN		●		●
LILAC		●		●
ROSE		●		●
SALMON		●		●
LEMON		●		●
ORANGE		●		●
FIRE		●		●

● Natural | ■ Grip R10

colour effect | k-color

PIETRA SERENA  
30x30 (12"x12")

---

# granigliati linea tecnica

4

COLORI/  
COLOURS  
COULEURS  
FARBE  
COLORES

1

FORMATI/  
SIZES  
FORMATS  
FORMATE  
FORMATOS

2

SUPERFICI/  
FINISHES  
FINITIONS  
OBERFLÄCHEN  
ACABADOS

2

SPESSORI/  
THICKNESS  
ÉPAISSEUR  
STÄRKE  
ESPESOR



# 7

**COLORI/**  
COLOURS / COULEURS / FARBE / COLORES

## linea tecnica

AURORA **VO**



## granigliati

AURORA **VO**



DIASPRO **VO**



BARDIGLIO **VO**



BARDIGLIO **VO**



PIETRA SERENA **VO**



PIETRA SERENA **VO**



# 1

**FORMATI/**  
SIZES / FORMATS / FORMATE / FORMATOS



●+ 30x30 (12"x12") Not RT 8,6 mm

# 8

**PEZZI SPECIALI/**  
TRIMS / PIECES SPECIALES / FORMTEILE /  
PIEZAS ESPECIALES

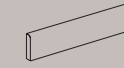

**BATTISCOPA**

BULLNOSE / PLINTHE /  
SOCKEL / RODAPIÉ

● 10x30 (4"x12") Not RT 8,6 mm

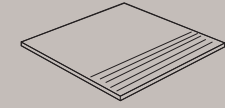

**GRADINO**

STEP TREAD / NEZ DE MARCHE  
STUFENPLATTE / PELDAÑO

● 30x30 (12"x12") Not RT 8,6 mm

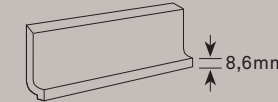

**RACCORDO A PAVIMENTO**

COVE BASE / PLINTHE À GORGE  
HOHLKEHLSOCKEL / UNIÓN DE PISO

● 10x30 (4"x12") Not RT 8,6 mm



**BATTISCOPA CON SGUSCIA**

COVE BASE / PLINTHE À TALON  
AUFSETZSOCKEL / ESCOCIA

● 10x30 (4"x12") Not RT 8,6 mm

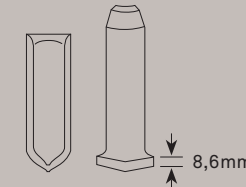

**ANGOLI RACCORDO INT./EST.**

CORNER INT./EXT / ANGLE INT./EST.  
INN/AUSS ECKE / ÁNGULOS INT./EXT.

● 10x3 (4"x1<sup>3/16</sup>") Not RT 8,6 mm

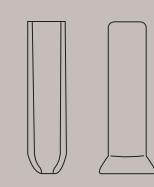

**ANGOLI SGUSCIA INT./EST.**

CORNER INT./EXT / ANGLE INT./EST.  
INN/AUSS ECKE / ÁNGULOS INT./EXT.

● 10x3 (4"x1<sup>3/16</sup>") Not RT 8,6 mm

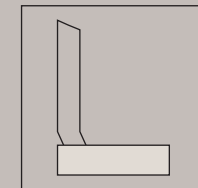
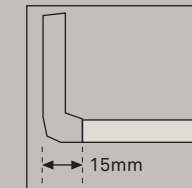

## FORMATI

FORMATS / FORMATS / FORMATE / FORMATOS

	30x30 12"x12"
	Not RT
	8,6 mm
AURORA	●+
BARDIGLIO	●+
DIASPRO	●
PIETRA SERENA	●+

● Natural R9 | + R12

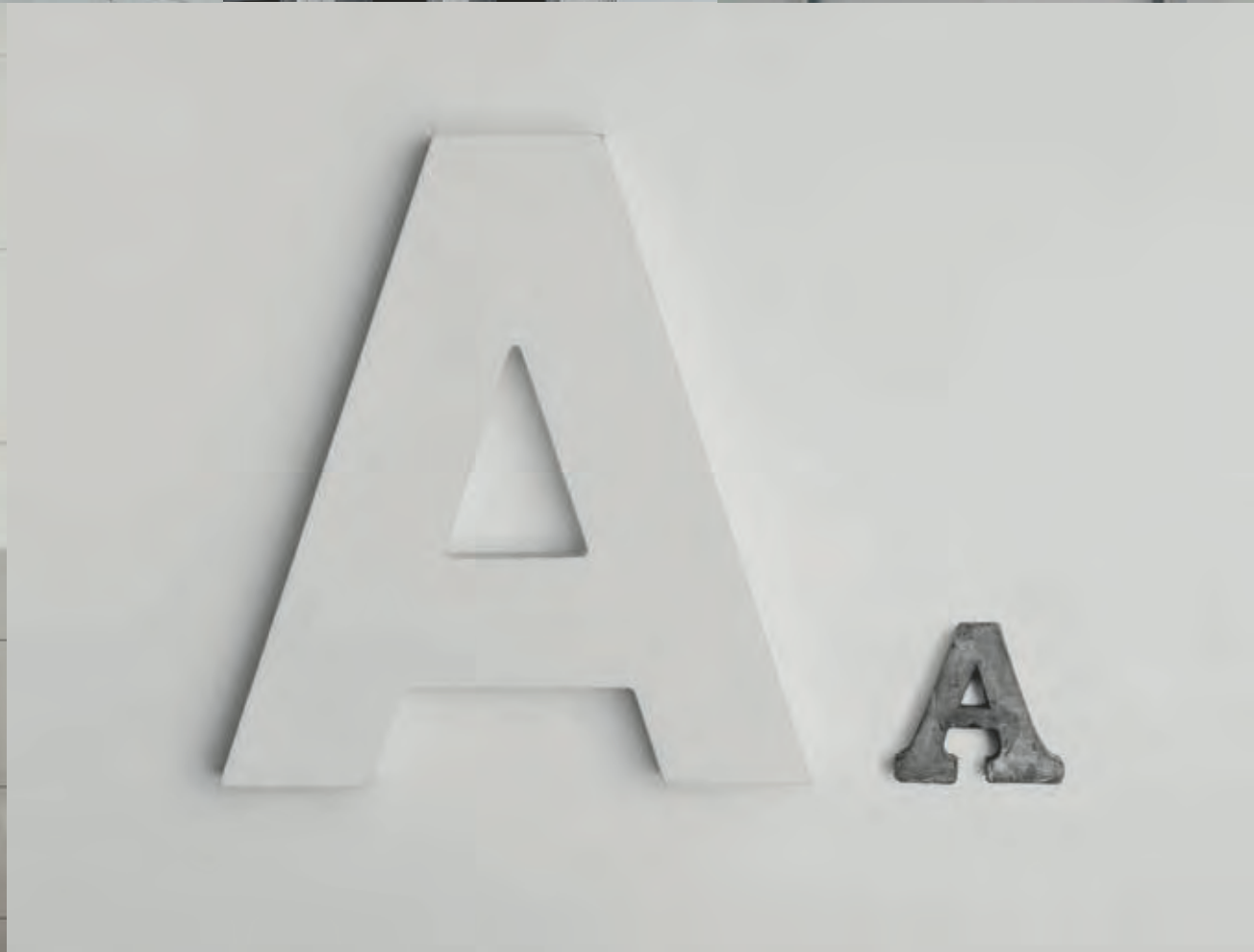

**120x278**  
(48"x110")

6 mm

**25**

*COLORI/  
COLOURS  
COULEURS  
FARBE  
COLORES*

**3**

*FINITURE/  
FINISHES  
FINITIONS  
OBERFLÄCHEN  
ACABADOS*

**9**

*COLLEZIONI/  
COLLECTIONS  
COLLECTIONS  
KOLLEKTIONEN  
COLECCIONES*

# COLORI E FINITURE

COLORS AND FINISHES / COULEURS ET FINITIONS / FARBEN UND OBERFLÄCHEN / COLORES Y ACABADOS

## 9CENTO

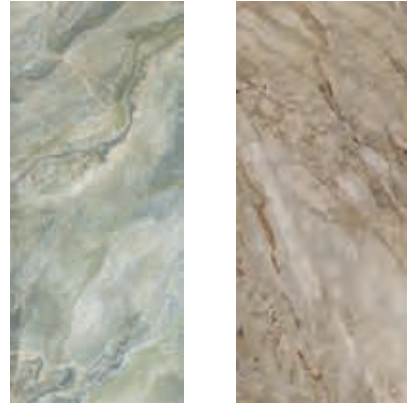

◆ Raggio Verde ◆ Aurora Beige

## ECLECTIC

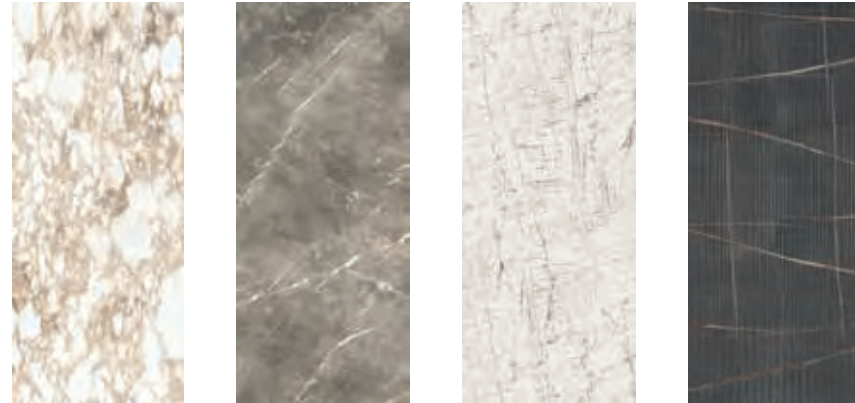

◆ Oniric White ✕ Persian Grey ◆ Mistiq White ✕ Pinstripe Dark

## BRYSTONE



● Ivory ● Gold

## DOLMIX



● Grey

## IKON



● Silver ● Grey

## ELEMENTS LUX



◆ Calacatta ◆ Silver Grey ◆ Calacatta Gold ◆ Port Laurent ◆ Emperador

## ELEMENTS DESIGN



● White ● Grey ● Beige

## MOOV



● Ivory ● Grey

## INTERNO4



◆ Breccia Tortona ◆ Renoir Isola ◆ C. San Babila ◆ Carnico Brera

120x278 6mm

● Natural R9 | ◆ Lappato | ✕ Silky



# K2 20 mm

**66**

COLORI/  
COLOURS  
COULEURS  
FARBE  
COLORES

**14**

FORMATI/  
SIZES  
FORMATS  
FORMATE  
FORMATOS

**22**

COLLEZIONI/  
COLLECTIONS  
COLLECTIONS  
KOLLEKTIONEN  
COLECCIONES



# COLORI E FORMATI

COLORS AND SIZES / COULEURS ET FORMATS / FARBEN UND FORMATE / COLORES Y FORMATOS

**120x240 48"x96"**

<b>PERCORSI SMART</b>	<b>PERCORSI EXTRA</b>	<b>P.SMART</b>
Pietra di Bagnolo	Pietra di Bressa	Pietra di Lavis
Pietra di Vals	Pietra di Bressa	Pietra di Bagnolo

**120x120 48"x48"**

<b>DOLMIX</b>	<b>PERCORSI EXTRA</b>	<b>MOOV</b>
Grey	Pietra di Vals	Grey
Pietra di Barge	Moka	Anthracite

**120x120 48"x48"**

<b>PERCORSI SMART</b>	<b>NOORD</b>
Pietra di Bagnolo	Grey
Pietra di Bressa	White

**40x120 16"x48"**

<b>BEAT</b>	<b>PERCORSI EXTRA</b>	<b>EVOKE</b>
Grey	Pietra di Vals	Brown
Walnut	Pietra di Barge	Sand

**30x120 12"x48"**

<b>SOUL</b>	<b>EVOKE</b>
Grey	Walnut
Blend	

**80x80 32"x32"**

<b>NOORD</b>	<b>BRYSTONE</b>	<b>PERCORSI EXTRA</b>
Grey	Grey	Pietra di Vals
White	Gold	Pietra di Barge
Anthracite	White	

**60x120 24"x48"**

<b>CHORUS</b>	<b>ELEMENT DESIGN</b>
Beige	Grey
Silver	Beige
White	White

**60x120 24"x48"**

<b>UBIK</b>	<b>PERCORSI EXTRA</b>
Anthracite	Pietra di Vals
Grey	Pietra di Barge
Greige	
Ivory	
Walnut	

**60x120 24"x48"**

<b>ARAN</b>	<b>PERCORSI EXTRA</b>
Walnut	Pietra di Vals
Silver	Pietra di Barge
Anthracite	

**60x120 24"x48"**

<b>ARTEMIS</b>
Silver
Beige

**90x90 36"x36"**

<b>MOOV</b>	<b>IKON</b>
Grey	Beige
Beige	Silver
Moka	White
Anthracite	

**60x90 24"x36"**

<b>LIMES</b>	<b>BRYSTONE</b>
Porfido Cold	Grey
Porfido Warm	Ivory
Quartz White	Gold
Quartz Multicolor	

**60x90 24"x36"**

<b>MIDLAKE</b>
Quartzbeige
Porfido
Quartzgrey
Ardesia

**45x90 18"x36"**

<b>PERCORSI EXTRA</b>	<b>PERCORSI SMART</b>
Pietra di Vals	Pietra di Bagnolo
Pietra di Faedis	Pietra di Bressa
Pietra di Combe	Pietra di Lavis
Pietra di Barge	

**EXTREME - Contract**

Grey	Beige	Anthracite

# COLORI E FORMATI

COLORS AND SIZES / COULEURS ET FORMATS / FARBEN UND FORMATE / COLORES Y FORMATOS

<b>60x60</b> 24"x24"	<b>DOLMIX</b>	<b>UBIK</b>					<b>MOOV</b>			
	Grey	Grey	Ivory	Anthracite	Greige	Walnut	Grey	Beige	Moka	Anthracite
	<b>CHORUS</b>			<b>NOORD</b>				<b>IKON</b>		
	Beige	White	Silver	Grey	Gold	White	Anthracite	Beige	Silver	White
	<b>BACK</b>		<b>PERCORSI EXTRA</b>				<b>PERCORSI QUARTZ</b>		<b>SIGHT</b>	
	Grey	Anthracite	P. di Vals	P. di Faedis	P. di Combe	P. di Barge	White	Black	Grey	Anthracite
	<b>PERCORSI SMART</b>		<b>SWISSTONE - Contract</b>				<b>EXTREME - Contract</b>			
P. di Bagnolo	P. di Bressa	P. di Lavis	Grey	Taupe	Anthracite	Beige	Grey	Beige	Anthracite	
<b>SKYWALL - Contract</b>		<b>ARTEMIS</b>								
Beige	Grey	Beige	Silver							
<b>30x60</b> 12"x24"	<b>CHORUS</b>									
	White	Beige	Silver							
	<b>NOORD</b>									
Grey	Gold	White	Anthracite							
<b>22,5x45,4</b> 9"x18"	<b>MIDLAKE</b>									
	Q.beige	Q.grey								
Porfido	Ardesia									
<b>22,5x22,5</b> 9"x9"	<b>MIDLAKE</b>									
	Q.beige	Q.grey								
Porfido	Ardesia									

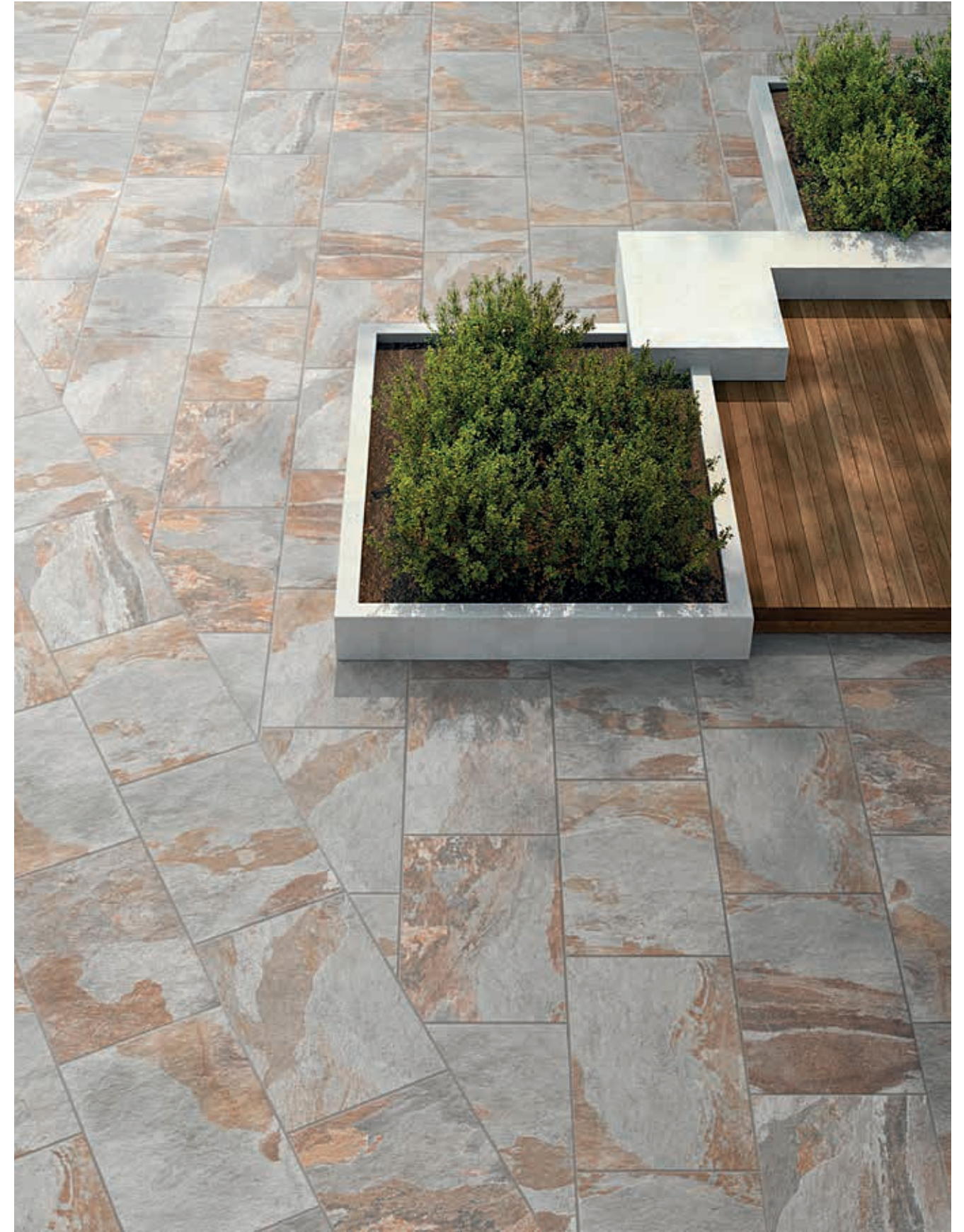

K2 20 mm



# K3 30 mm

60x60

**7**

COLORI/  
COLOURS  
COULEURS  
FARBE  
COLORES

**1**

FORMATO/  
SIZES  
FORMATS  
FORMATE  
FORMATOS

**3**

COLLEZIONI/  
COLLECTIONS  
COLLECTIONS  
KOLLEKTIONEN  
COLECCIONES

# COLORI E FINITURE

COLORS AND FINISHES / COULEURS ET FINITIONS / FARBEN UND OBERFLÄCHEN / COLORES Y ACABADOS

**60x60** 24"x24"

## PERCORSI SMART



Pietra di Bagnolo



Pietra di Bressa

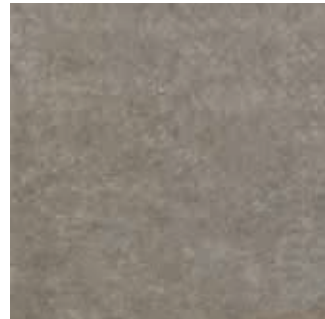

Petra di Lavis

## MOOV



Grey



Moka

## PERCORSI EXTRA



Pietra di Vals

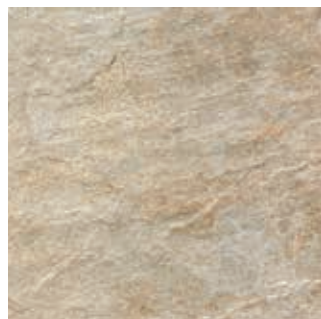

Pietra di Barge



K3 30mm

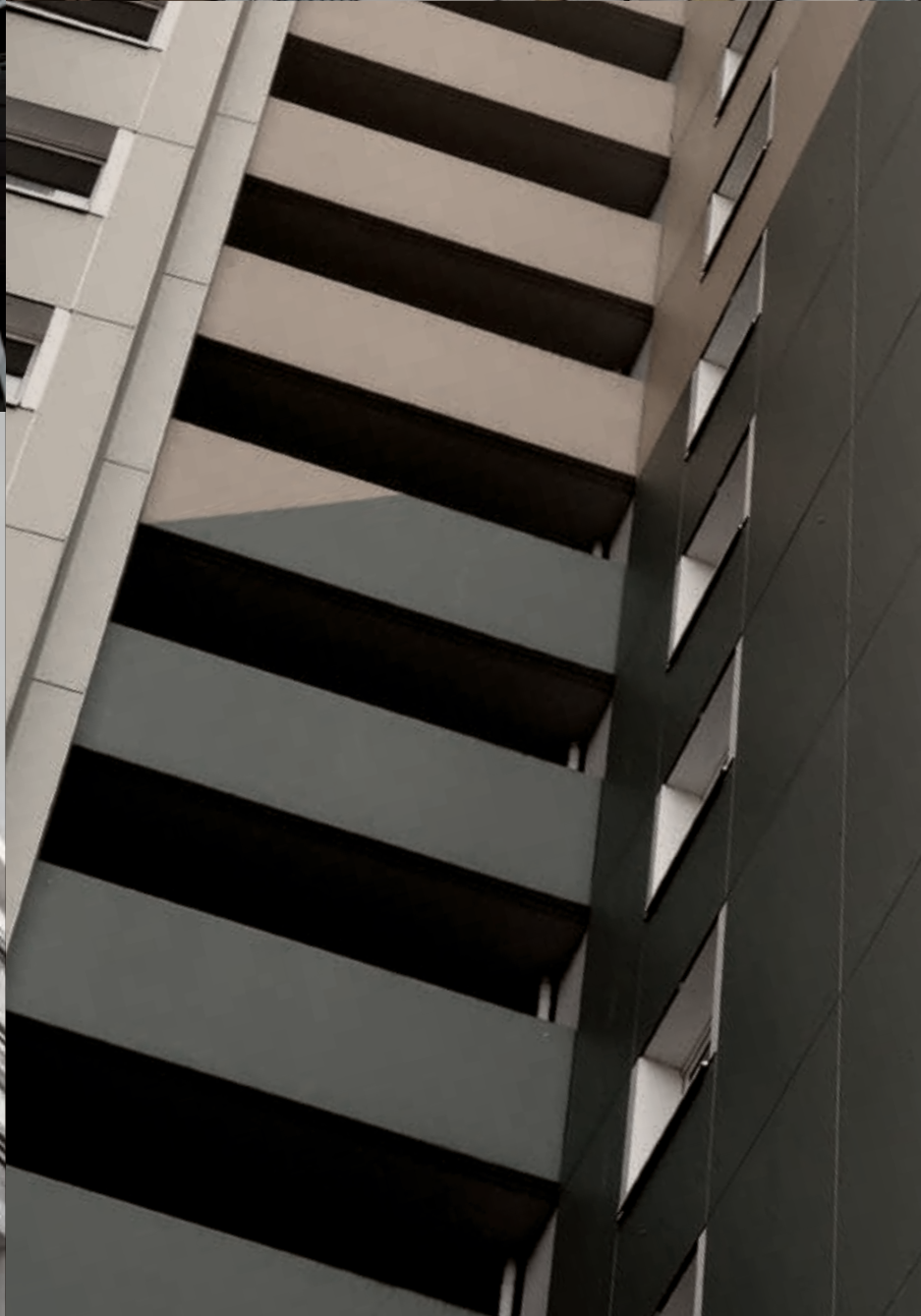

# contract

280 / Point

284 / Code

288 / Dunstone

292 / Londale

296 / Swisstone

300 / Extreme

304 / Skywall

308 / Urban

POINT BEIGE MULTICOLOR  
30x30 (12"x12") - 15x30 (6"x12")

# point

STONE EFFECT

4

COLORI/  
COLOURS  
COULEURS  
FARBE  
COLORES

3

FORMATI/  
SIZES  
FORMATS  
FORMATE  
FORMATOS

1

SUPERFICI/  
FINISHES  
FINITIONS  
OBERFLÄCHEN  
ACABADOS

1

SPESSORI/  
THICKNESS  
ÉPAISSEUR  
STÄRKE  
ESPESOR



# 4

## COLORI/

COLOURS / COULEURS / FARBE / COLORES

POINT SILVER **V3**



POINT BEIGE MULTICOLOR **V4**



POINT GREY MULTICOLOR **V4**

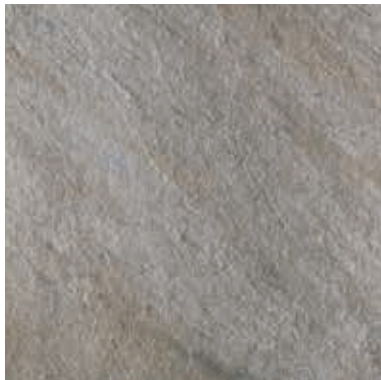

POINT SAND **V3**

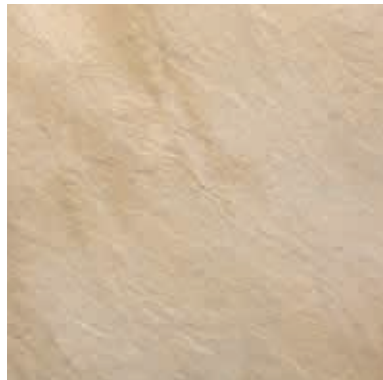

# 3

## FORMATI/

SIZES / FORMATS / FORMATE / FORMATOS

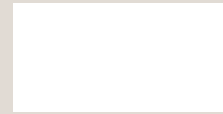

▲ 30x60 (12"x24") Not RT 8,5 mm

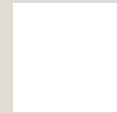

▲ 30x30 (12"x12") Not RT 8,5 mm



▲ 15x30 (6"x12") Not RT 8,5 mm

# 2

## PEZZI SPECIALI/

TRIMS / PIECES SPECIALES / FORMTEILE /  
PIEZAS ESPECIALES



### BATTISCOPA

BULLNOSE / PLINTHE / SOCKEL / RODAPIÉ

▲ 8x30 (3"x12") Not RT 8,5 mm

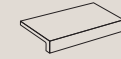

### TERMINALE L MONOLITICO

L TERMINAL / TERMINALE ELLE /

L STÜCK FLIESE / REMATE EN FORMA DE L

▲ 30x3,8x16,5 (12"x1 1/2"x6 1/2") Not RT 10 mm

## FORMATI

FORMATS / FORMATS / FORMATE / FORMATOS

	30x60 12"x24"	30x30 12"x12"	15x30 6"x12"
	Not RT 8,5 mm	Not RT 8,5 mm	Not RT 8,5 mm
POINT SILVER	▲	▲	▲
POINT BEIGE MULTICOLOR	▲	▲	▲
POINT GREY MULTICOLOR	▲	▲	▲
POINT SAND	▲	▲	▲

▲ Structured R11

CODE ANTHRACITE  
60x120 (24"x48")

# code

STONE EFFECT

4

COLORI/  
COLOURS  
COULEURS  
FARBE  
COLORES

3

FORMATI/  
SIZES  
FORMATS  
FORMATE  
FORMATOS

1

SUPERFICI/  
FINISHES  
FINITIONS  
OBERFLÄCHEN  
ACABADOS

2

SPESSORI/  
THICKNESS  
ÉPAISSEUR  
STÄRKE  
ESPESOR





# 4

## COLORI/

COLOURS / COULEURS / FARBE / COLORES

CODE IVORY V2



CODE BEIGE V2



CODE ANTHRACITE V2



CODE GREY V2



# 3

## FORMATI/

SIZES / FORMATS / FORMATE / FORMATOS

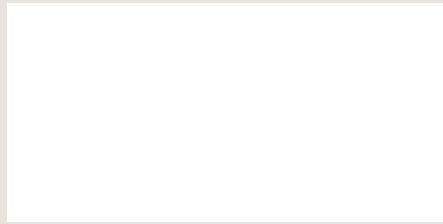

● 60x120 (24"x48") RT 9 mm

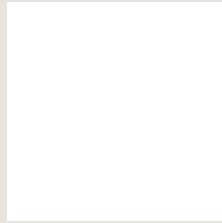

● 60x60 (24"x24") RT 8,5 mm

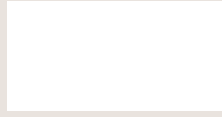

● 30x60 (12"x24") RT 8,5 mm

● Natural R9

# 5

## PEZZI SPECIALI/

TRIMS / PIECES SPECIALES / FORMTEILE /  
PIEZAS ESPECIALES



### BATTISCOPA

BULLNOSE / PLINTHE / SOCKEL / RODAPIÉ

● 7,2x60 (2,8"x24") RT 8,5 mm

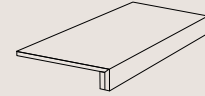

### SCALINO INCOLLATO

GLUED STEP TREAD / NEZ DE MARCHE COLLÉ /  
GEKLEBTE STUFENPLATTE / PELDAÑO CON PERFIL PEGADO

● 33x60 (13"x24") RT 8,5 mm



### SCALINO ANGOLARE INCOLLATO

GLUED CORNER STEP TREAD / CARREAU DE MARCHE COLLÉ  
PIÈCE ANGULAIRE / GEKLEBTE STUFENPLATTE ECKSTÜCK /  
PELDAÑO ESQUINA CON PERFIL PEGADO

● 33x33 (13"x13") RT 8,5 mm

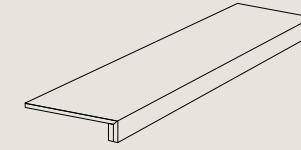

### SCALINO INCOLLATO

GLUED STEP TREAD / NEZ DE MARCHE COLLÉ /  
GEKLEBTE STUFENPLATTE / PELDAÑO CON PERFIL PEGADO

● 33x120 (13"x48") RT 9 mm

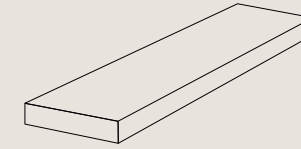

### SCALINO ANGOLARE INCOLLATO

GLUED CORNER STEP TREAD / CARREAU DE MARCHE COLLÉ  
PIÈCE ANGULAIRE / GEKLEBTE STUFENPLATTE ECKSTÜCK /  
PELDAÑO ESQUINA CON PERFIL PEGADO

● 33x120 (13"x48") RT 9 mm

## FORMATI

FORMATS / FORMATS / FORMATE / FORMATOS

	60x120 24"x48"	60x60 24"x24"	30x60 12"x24"
working size	596x1195	596x596	297x596
	RT	RT	RT
	9 mm	8,5 mm	8,5 mm
CODE IVORY	●	●	●
CODE BEIGE	●	●	●
CODE GREY	●	●	●
CODE ANTHRACITE	●	●	●

● Natural R9

DUNSTONE GREY  
60x120 (24"x48")

# dunstone

STONE EFFECT

**3**

COLORI/  
COLOURS  
COULEURS  
FARBE  
COLORES

**3**

FORMATI/  
SIZES  
FORMATS  
FORMATE  
FORMATOS

**1**

SUPERFICI/  
FINISHES  
FINITIONS  
OBERFLÄCHEN  
ACABADOS

**1**

SPESSORI/  
THICKNESS  
ÉPAISSEUR  
STÄRKE  
ESPESOR



# 3

## COLORI/

COLOURS / COULEURS / FARBE / COLORES

DUNSTONE IVORY V3



DUNSTONE BEIGE V3



LEED  
COMPLIANT

DUNSTONE GREY V3

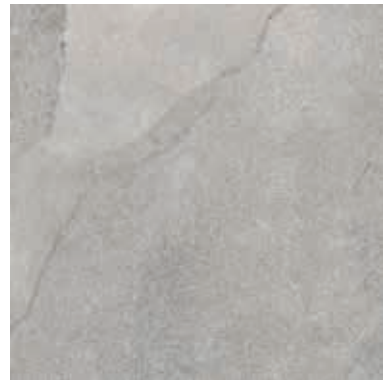

LEED  
COMPLIANT

# 3

## FORMATI/

SIZES / FORMATS / FORMATE / FORMATOS

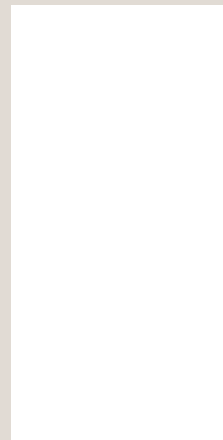

● 60x120 (24"x48") RT 9 mm

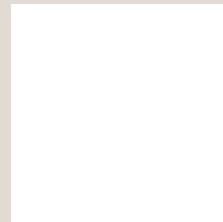

● 60x60 (24"x24") RT 8,5 mm

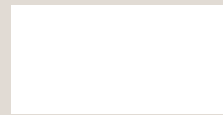

● 30x60 (12"x24") RT 8,5 mm

# 5

## PEZZI SPECIALI/

TRIMS / PIECES SPECIALES / FORMTEILE /  
PIEZAS ESPECIALES



### BATTISCOPA

BULLNOSE / PLINTHE / SOCKEL / RODAPIÉ

● 7,2x60 (2.8"x24") RT 8,5 mm

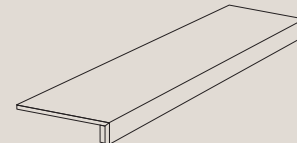

### SCALINO INCOLLATO

GLUED STEP TREAD / NEZ DE MARCHE COLLÉ /  
GEKLEBTE STUFENPLATTE / PELDAÑO CON PERFIL PEGADO

● 33x120 (13"x48") RT 9 mm

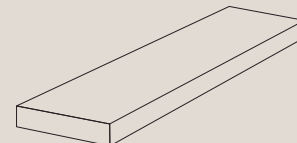

### SCALINO ANGOLARE INCOLLATO

GLUED CORNER STEP TREAD / CARREAU DE MARCHE COLLÉ  
PIÈCE ANGULAIRE / GEKLEBTE STUFENPLATTE ECKSTÜCK /  
PELDAÑO ESQUINA CON PERFIL PEGADO

● 33x120 (13"x48") RT 9 mm



### SCALINO INCOLLATO

GLUED STEP TREAD / NEZ DE MARCHE COLLÉ /  
GEKLEBTE STUFENPLATTE / PELDAÑO CON PERFIL PEGADO

● 33x60 (13"x24") RT 8,5 mm



### SCALINO ANGOLARE INCOLLATO

GLUED CORNER STEP TREAD / CARREAU DE MARCHE COLLÉ  
PIÈCE ANGULAIRE / GEKLEBTE STUFENPLATTE ECKSTÜCK /  
PELDAÑO ESQUINA CON PERFIL PEGADO

● 33x33 (13"x13") RT 8,5 mm

## FORMATI

FORMATS / FORMATS / FORMATE / FORMATOS

	60x120 24"x48"	60x60 24"x24"	30x60 12"x24"
working size	596x1195	596x596	297x596
	RT	RT	RT
	9 mm	8,5 mm	8,5 mm
DUNSTONE IVORY	●	●	●
DUNSTONE BEIGE	●	●	●
DUNSTONE GREY	●	●	●

● Natural R9

● Natural R9

LONDALE GREY  
60x120 (24"x48")

# londale

CONCRETE EFFECT

**3**

COLORI/  
COLOURS  
COULEURS  
FARBE  
COLORES

**3**

FORMATI/  
SIZES  
FORMATS  
FORMATE  
FORMATOS

**1**

SUPERFICI/  
FINISHES  
FINITIONS  
OBERFLÄCHEN  
ACABADOS

**1**

SPESSORI/  
THICKNESS  
ÉPAISSEUR  
STÄRKE  
ESPESOR



# 3

## COLORI/

COLOURS / COULEURS / FARBE / COLORES

LONDALE SILVER V3



LONDALE BEIGE V3



LONDALE GREY V3



# 3

## FORMATI/

SIZES / FORMATS / FORMATE / FORMATOS

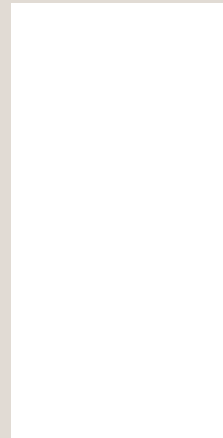

● 60x120 (24"x48") RT 9 mm

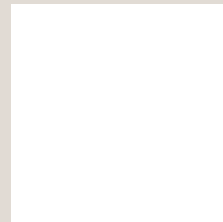

● 60x60 (24"x24") RT 8,5 mm

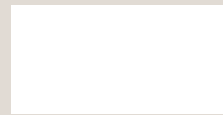

● 30x60 (12"x24") RT 8,5 mm

# 5

## PEZZI SPECIALI/

TRIMS / PIECES SPECIALES / FORMTEILE /  
PIEZAS ESPECIALES



### BATTISCOPA

BULLNOSE / PLINTHE / SOCKEL / RODAPIÉ

● 7,2x60 (2.8"x24") RT 8,5 mm

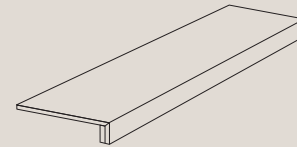

### SCALINO INCOLLATO

GLUED STEP TREAD / NEZ DE MARCHE COLLÉ / GEKLEBTE  
STUFENPLATTE / PELDAÑO CON PERFIL PEGADO

● 33x120 (13"x48") RT 9 mm

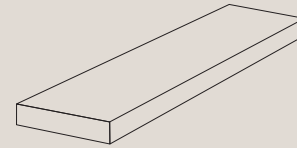

### SCALINO ANGOLARE INCOLLATO

GLUED CORNER STEP TREAD / CARREAU DE MARCHE COLLÉ  
PIÈCE ANGULAIRE / GEKLEBTE STUFENPLATTE ECKSTÜCK /  
PELDAÑO ESQUINA CON PERFIL PEGADO

● 33x120 (13"x48") RT 9 mm

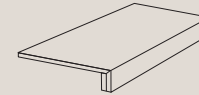

### SCALINO INCOLLATO

GLUED STEP TREAD / NEZ DE MARCHE COLLÉ / GEKLEBTE  
STUFENPLATTE / PELDAÑO CON PERFIL PEGADO

● 33x60 (13"x24") RT 8,5 mm



### SCALINO ANGOLARE INCOLLATO

GLUED CORNER STEP TREAD / CARREAU DE MARCHE COLLÉ  
PIÈCE ANGULAIRE / GEKLEBTE STUFENPLATTE ECKSTÜCK /  
PELDAÑO ESQUINA CON PERFIL PEGADO

● 33x33 (13"x13") RT 8,5 mm

## FORMATI

FORMATS / FORMATS / FORMATE / FORMATOS

	60x120 24"x48"	60x60 24"x24"	30x60 12"x24"
working size	596x1195	596x596	297x596
	RT	RT	RT
	9 mm	8,5 mm	8,5 mm
LONDALE SILVER	●	●	●
LONDALE BEIGE	●	●	●
LONDALE GREY	●	●	●

● Natural R9

● Natural R9

SWISSTONE GREY  
60x120 (24"x48")

# swisstone

STONE EFFECT

4

COLORI/  
COLOURS  
COULEURS  
FARBE  
COLORES

4

FORMATI/  
SIZES  
FORMATS  
FORMATE  
FORMATOS

2

SUPERFICI/  
FINISHES  
FINITIONS  
OBERFLÄCHEN  
ACABADOS

2

SPESSORI/  
THICKNESS  
ÉPAISSEUR  
STÄRKE  
ESPESOR



# 4

## COLORI/

COLOURS / COULEURS / FARBE / COLORES

SWISSTONE ANTHRACITE V3 **LEED COMPLIANT**

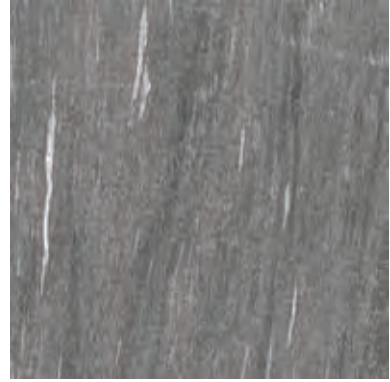

SWISSTONE GREY V3 **LEED COMPLIANT**



SWISSTONE TAUPE V3 **LEED COMPLIANT**

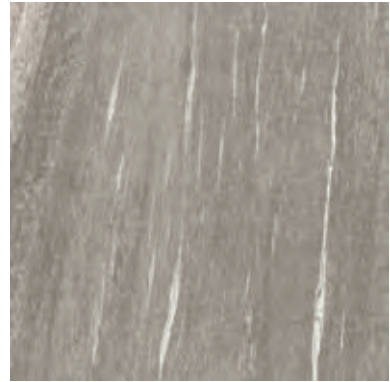

SWISSTONE BEIGE V3 **LEED COMPLIANT**



# 4

## FORMATI/

SIZES / FORMATS / FORMATE / FORMATOS

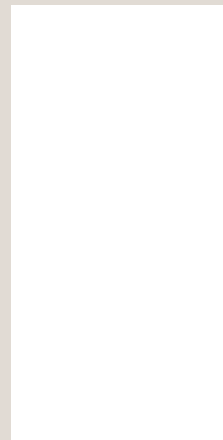

■ 60x120 (24"x48") RT 9 mm

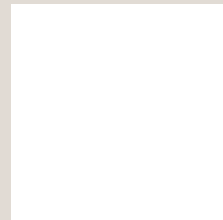

■ 60x60 (24"x24") RT 8,5 mm  
▲ 60x60 (24"x24") RT → K2 20 mm



■ 30x60 (12"x24") RT 8,5 mm

# 5

## PEZZI SPECIALI/

TRIMS / PIECES SPECIALES / FORMTEILE / PIEZAS ESPECIALES



**BATTISCOPA**  
BULLNOSE / PLINTHE / SOCKEL / RODAPIÉ  
■ 7,2x60 (2.8"x24") RT 8,5 mm

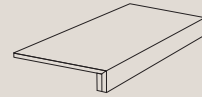

**SCALINO INCOLLATO**  
GLUED STEP TREAD / NEZ DE MARCHE COLLÉ / GEKLEBTE STUFENPLATTE / PELDAÑO CON PERFIL PEGADO  
■ 33x60 (13"x24") RT 8,5 mm



**SCALINO ANGOLARE INCOLLATO**  
GLUED CORNER STEP TREAD / CARREAU DE MARCHE COLLÉ / PIÈCE ANGULAIRE / GEKLEBTE STUFENPLATTE ECKSTÜCK / PELDAÑO ESQUINA CON PERFIL PEGADO  
■ 33x33 (13"x13") RT 8,5 mm

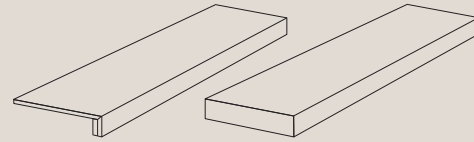

**SCALINO INCOLLATO**  
GLUED STEP TREAD / NEZ DE MARCHE COLLÉ / GEKLEBTE STUFENPLATTE / PELDAÑO CON PERFIL PEGADO  
■ 33x120 (13"x48") RT 9 mm

**SCALINO ANGOLARE INCOLLATO**  
GLUED CORNER STEP TREAD / CARREAU DE MARCHE COLLÉ / PIÈCE ANGULAIRE / GEKLEBTE STUFENPLATTE ECKSTÜCK / PELDAÑO ESQUINA CON PERFIL PEGADO  
■ 33x120 (13"x48") RT 9 mm

## FORMATI

FORMATS / FORMATS / FORMATE / FORMATOS

	60x120 24"x48"	60x60 24"x24"	30x60 12"x24"	60x60 24"x24"
working size	596x1195	596x596	297x596	596x596
	RT	RT	RT	RT
	9 mm	8,5 mm	8,5 mm	K2 20 mm
SWISSTONE ANTHRACITE	■	■	■	▲
SWISSTONE GREY	■	■	■	▲
SWISSTONE TAUPE	■	■	■	▲
SWISSTONE BEIGE	■	■	■	▲

■ Structured R10 | ▲ Structured R11

# 10

## PEZZI SPECIALI K2/

TRIMS K2 / PIECES SPECIALES K2 / FORMTEILE K2 / PIEZAS ESPECIALES K2



**ANGOLARE BORDO TORO**  
CORNER STEP TREAD / NEZ DE MARCHE ANGULAIRE / STUFENPLATTE ECKSTÜCK / ANGULAR CANTO ROMO  
▲ 30x30 (12"x12") RT 20 mm

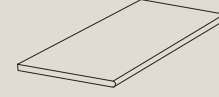

**GRADINO BORDO TORO**  
ROUNDED STEP TREAD / NEZ DE MARCHE ARRONDI / GERUNDET STUFENPLATTE / PELDAÑO CANTO ROMO  
▲ 30x60 (12"x24") RT 20 mm

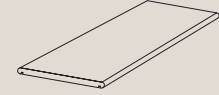

**TOP BORDO TORO**  
TOP STEP TREAD / NEZ DE MARCHE HAUT / STUFENPLATTE TOP / TOP CANTO ROMO  
▲ 30x60 (12"x24") RT 20 mm

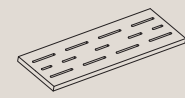

**GRIGLIA**  
GRID / GRIL / GRILL / REJILLA  
▲ 15x60 (6"x24") RT 20 mm

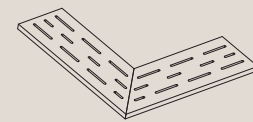

**ANGOLARE GRIGLIA**  
GRID / GRIL / GRILL / ANGULAR REJILLA  
▲ 15x60 (6"x24") RT 20 mm

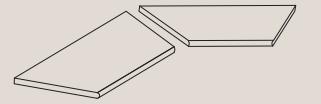

**ANGOLARE INTERNO BORDO TORO**  
INT. CORNER STEP TREAD / ANGLE INT. NEZ DE MARCHE / INNENECKTRITTSTUFE / ANG. INT. CANTO ROMO  
▲ 30x60 (12"x24") RT 20 mm

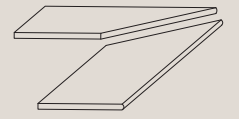

**ANGOLARE ESTERNO BORDO TORO**  
EXT. CORNER STEP TREAD / ANGLE EXT. NEZ DE MARCHE / AUSSENECKTRITTSTUFE / ANG. EXT. CANTO ROMO  
▲ 30x60 (12"x24") RT 20 mm

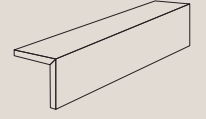

**CORDOLO L**  
GLUED "L" TERMINAL / TERMINAL "L" COLLÉ / "L" STÜCK FLIESE GEKLEBT / CANTONERA "L" (PEGADA)  
▲ 60x20x15 (24"x8" x6") RT 20 mm

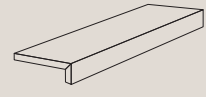

**TERMINALE L**  
GLUED "L" TERMINAL / TERMINAL "L" COLLÉ / "L" STÜCK FLIESE GEKLEBT / TERMINAL "L" (PEGADO)  
▲ 60x20x5 (24"x8" x2") RT 20 mm

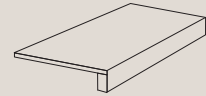

**TERMINALE L**  
GLUED "L" TERMINAL / TERMINAL "L" COLLÉ / "L" STÜCK FLIESE GEKLEBT / TERMINAL "L" (PEGADO)  
▲ 60x33x5 (24"x13" x2") RT 20 mm

EXTREME GREY  
45x90 (18"x36") K2 20 mm

# extreme

STONE EFFECT

**3**

COLORI/  
COLOURS  
COULEURS  
FARBE  
COLORES

**2**

FORMATI/  
SIZES  
FORMATS  
FORMATE  
FORMATOS

**1**

SUPERFICI/  
FINISHES  
FINITIONS  
OBERFLÄCHEN  
ACABADOS

**1**

SPESSORI/  
THICKNESS  
ÉPAISSEUR  
STÄRKE  
ESPESOR

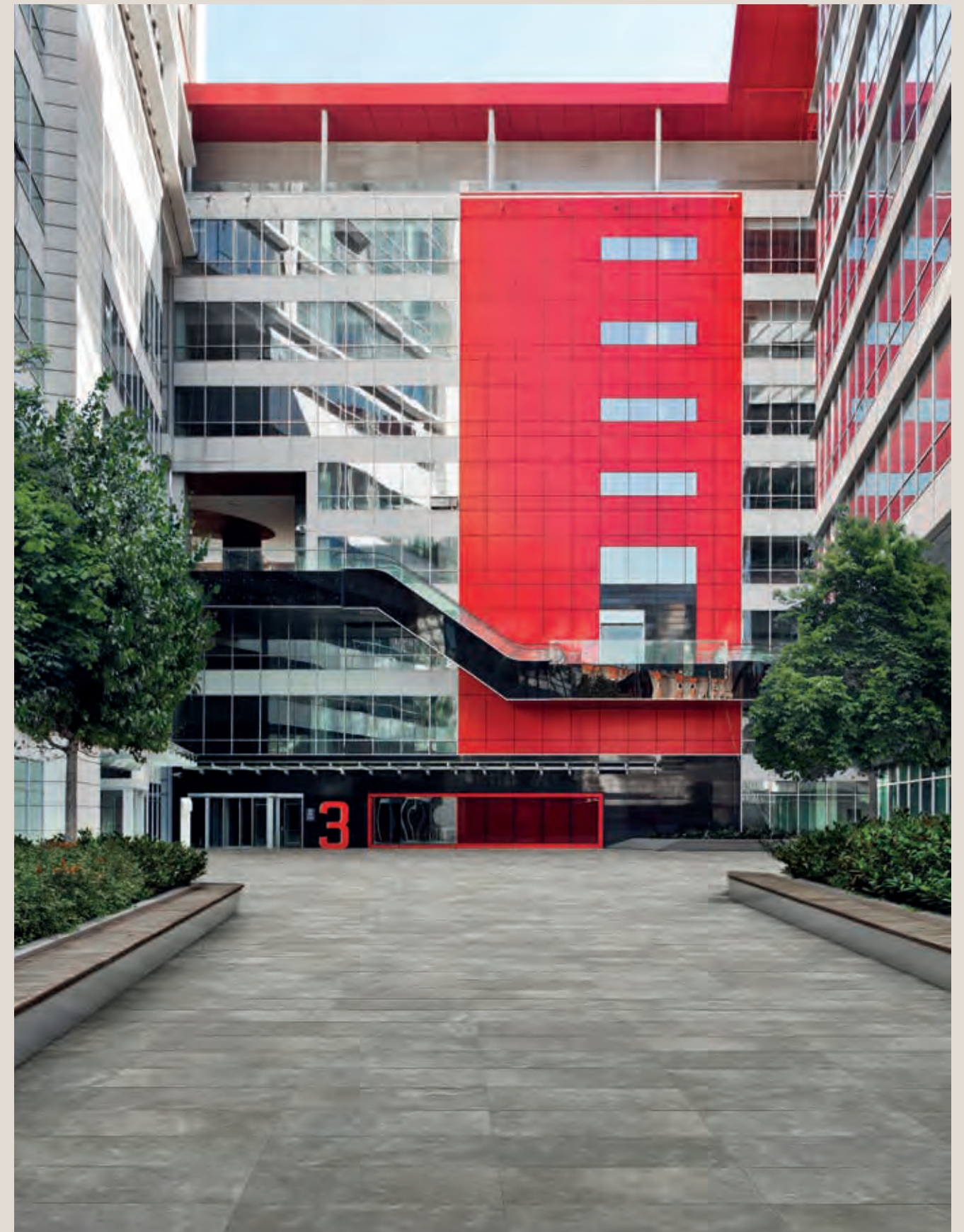



# 3

## COLORI/

COLOURS / COULEURS / FARBE / COLORES

EXTREME BEIGE V3



EXTREME GREY V3



EXTREME ANTHRACITE V3

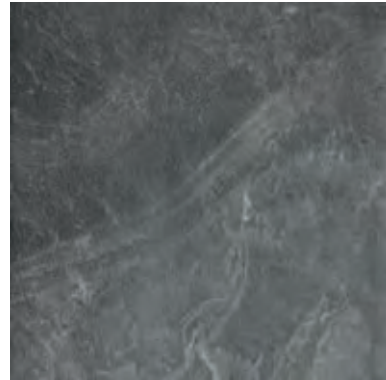

# 2

## FORMATI/

SIZES / FORMATS / FORMATE / FORMATOS



▲ 45x90 (18"x36") RT K2 20 mm

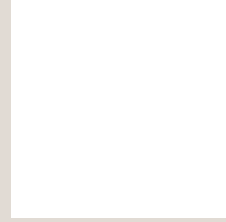

▲ 60x60 (24"x24") RT K2 20 mm

# 14

## PEZZI SPECIALI K2/

TRIMS K2 / PIECES SPECIALES K2 / FORMTEILE K2 / PIEZAS ESPECIALES K2



**ANGOLARE BORDO TORO**  
CORNER STEP TREAD / NEZ DE MARCHE ANGULAIRE / STUFENPLATTE ECKSTÜCK / ANGULAR CANTO ROMO  
▲ 30x30 (12"x12") RT 20 mm

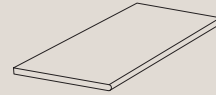

**GRADINO BORDO TORO**  
ROUNDED STEP TREAD / NEZ DE MARCHE ARRONDI / GERUNDET STUFENPLATTE / PELDAÑO CANTO ROMO  
▲ 45x90 (18"x36") RT 20 mm  
▲ 30x60 (12"x24") RT 20 mm

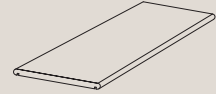

**TOP BORDO TORO**  
TOP STEP TREAD / NEZ DE MARCHE HAUT / STUFENPLATTE TOP / TOP CANTO ROMO  
▲ 30x60 (12"x24") RT 20 mm

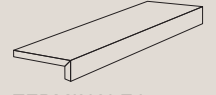

**TERMINALE L**  
GLUED "L" TERMINAL / TERMINAL "L" COLLÉ / "L" STÜCK FLIESE GEKLEBT / TERMINAL "L" (PEGADO)  
▲ 90x45x15 (36"x18"x6") RT 20 mm  
▲ 60x20x5 (24"x8"x2") RT 20 mm

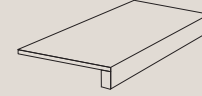

**SCALINO INCOLLATO**  
STEP TREAD / NEZ DE MARCHE / STUFENPLATTE / PELDAÑO (PEGADO)  
▲ 33x60x5 (13"x24"x2") RT 20 mm

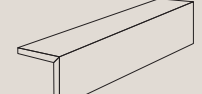

**CORDOLO L**  
GLUED "L" TERMINAL / TERMINAL "L" COLLÉ / "L" STÜCK FLIESE GEKLEBT / CANTONERA "L" (PEGADA)  
▲ 60x20x15 (24"x8" x6") RT 20 mm

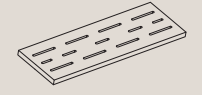

**GRIGLIA**  
GRID / GRIL / GRILL / REJILLA  
▲ 15x60 (6"x24") RT 20 mm

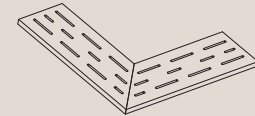

**ANGOLARE GRIGLIA**  
GRID / GRIL / GRILL / ANGULAR REJILLA  
▲ 15x60 (6"x24") RT 20 mm



**ANGOLARE INTERNO BORDO TORO**  
INT. CORNER STEP TREAD / ANGLE INT. NEZ DE MARCHE / INNENECKTRITTSTUFE / ANG. INT. CANTO ROMO  
▲ 45x90 (18"x36") RT 20 mm  
▲ 30x60 (12"x24") RT 20 mm



**ANGOLARE ESTERNO BORDO TORO**  
EXT. CORNER STEP TREAD / ANGLE EXT. NEZ DE MARCHE / AUSSENECKTRITTSTUFE / ANG. EXT. CANTO ROMO  
▲ 45x90 (18"x36") RT 20 mm  
▲ 30x60 (12"x24") RT 20 mm

## FORMATI

FORMATS / FORMATS / FORMATE / FORMATOS

	45x90 18"x36"	60x60 24"x24"
working size	446x895	596x596
	RT	RT
	K2 20 mm	K2 20 mm
<b>EXTREME BEIGE</b>	▲	▲
<b>EXTREME GREY</b>	▲	▲
<b>EXTREME ANTHRACITE</b>	▲	▲

▲ Structured R11

SKYWALL GREY  
60x60 (24"x24") K2 20 mm

# skywall

CONCRETE EFFECT

**2**

COLORI/  
COLOURS  
COULEURS  
FARBE  
COLORES

**1**

FORMATI/  
SIZES  
FORMATS  
FORMATE  
FORMATOS

**1**

SUPERFICI/  
FINISHES  
FINITIONS  
OBERFLÄCHEN  
ACABADOS

**1**

SPESSORI/  
THICKNESS  
ÉPAISSEUR  
STÄRKE  
ESPESOR



# 2

## COLORI/

COLOURS / COULEURS / FARBE / COLORES

### SKYWALL BEIGE V2

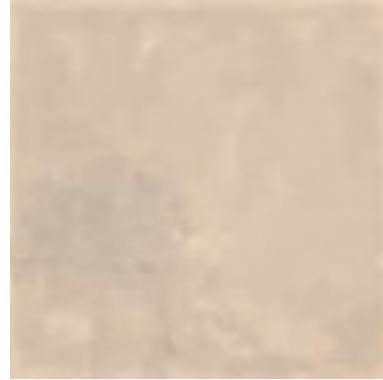

### SKYWALL GREY V2



# 1

## FORMATI/

SIZES / FORMATS / FORMATE / FORMATOS

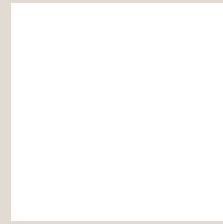

▲ 60x60 (24"x24") RT K2 20 mm

# 10

## PEZZI SPECIALI K2/

TRIMS K2 / PIECES SPECIALES K2 / FORMTEILE K2 /  
PIEZAS ESPECIALES K2



**ANGOLARE BORDO TORO**  
CORNER STEP TREAD / NEZ DE MARCHE ANGULAIRE /  
STUFENPLATTE ECKSTÜCK / ANGULAR CANTO ROMO  
▲ 30x30 (12"x12") RT 20 mm

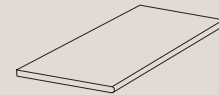

**GRADINO BORDO TORO**  
ROUNDED STEP TREAD / NEZ DE MARCHE ARRONDI /  
GERUNDET STUFENPLATTE / PELDAÑO CANTO ROMO  
▲ 30x60 (12"x24") RT 20 mm

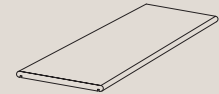

**TOP BORDO TORO**  
TOP STEP TREAD / NEZ DE MARCHE HAUT /  
STUFENPLATTE TOP / TOP CANTO ROMO  
▲ 30x60 (12"x24") RT 20 mm

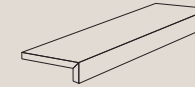

**TERMINALE L**  
GLUED "L" TERMINAL / TERMINAL "L" COLLÉ /  
"L" STÜCK FLIESE GEKLEBT / TERMINAL "L" (PEGADO)  
▲ 60x33x5 (24"x13"x2") RT 20 mm  
▲ 60x20x5 (24"x8"x2") RT 20 mm

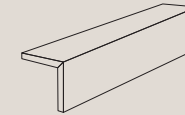

**CORDOLO L**  
GLUED "L" TERMINAL / TERMINAL "L" COLLÉ / "L"  
STÜCK FLIESE GEKLEBT / CANTONERA "L" (PEGADA)  
▲ 60x20x15 (24"x8"x6") RT 20 mm

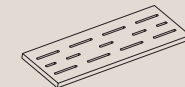

**GRIGLIA**  
GRID / GRIL / GRILL / REJILLA  
▲ 15x60 (6"x24") RT 20 mm



**ANGOLARE INTERNO BORDO TORO**  
INT. CORNER STEP TREAD / ANGLE INT. NEZ DE MARCHE /  
INNENECKTRITTSTUFE / ANG. INT. CANTO ROMO  
▲ 30x60 (12"x24") RT 20 mm



**ANGOLARE ESTERNO BORDO TORO**  
EXT. CORNER STEP TREAD / ANGLE EXT. NEZ DE MARCHE /  
AUSSENECKTRITTSTUFE / ANG. EXT. CANTO ROMO  
▲ 30x60 (12"x24") RT 20 mm

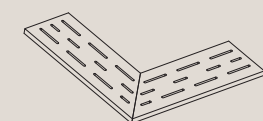

**ANGOLARE GRIGLIA**  
GRID / GRIL / GRILL / ANGULAR REJILLA  
▲ 15x60 (6"x24") RT 20 mm

## FORMATI

FORMATS / FORMATS / FORMATE / FORMATOS

	60x60 24"x24"
working size	596x596
	RT
	K2 20 mm
SKYWALL BEIGE	▲
SKYWALL GREY	▲

▲ Structured R11

URBAN GREY  
60x60 (24"x24")

# urban

CONCRETE EFFECT

3

COLORI/  
COLOURS  
COULEURS  
FARBE  
COLORES

2

FORMATI/  
SIZES  
FORMATS  
FORMATE  
FORMATOS

1

SUPERFICI/  
FINISHES  
FINITIONS  
OBERFLÄCHEN  
ACABADOS

1

SPESSORI/  
THICKNESS  
ÉPAISSEUR  
STÄRKE  
ESPESOR



# 3

## COLORI/

COLOURS / COULEURS / FARBE / COLORES

URBAN IVORY V2



URBAN GREY V2



URBAN ANTHRACITE V2



# 2

## FORMATI/

SIZES / FORMATS / FORMATE / FORMATOS

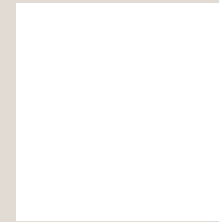

■ 60x60 (24"x24") RT 8,5 mm

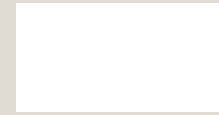

■ 30x60 (12"x24") RT 8,5 mm

# 1

## PEZZI SPECIALI/

TRIMS / PIECES SPECIALES / FORMTEILE /  
PIEZAS ESPECIALES



**BATTISCOPA**  
BULLNOSE / PLINTHE / SOCKEL / RODAPIÉ  
■ 7,2x60 (2,8"x24") RT 8,5 mm

## FORMATI

FORMATS / FORMATS / FORMATE / FORMATOS

	60x60 24"x24"	30x60 12"x24"
working size	596x596	297x596
	RT	RT
	8,5 mm	8,5 mm
URBAN IVORY	■	■
URBAN GREY	■	■
URBAN ANTHRACITE	■	■

■ Grip R10

# specs & tech

**314 / Legenda & simbologia**

**316 / Tabella gamma 2021**

**332 / Tabella informazioni tecniche**

**346 / Tabella DIN51130-DIN51097**

**350 / Misure-pesi-imballi**

**356 / Certificazioni**

**370 / Manuale di posa, uso e manutenzione**













**388 / Condizioni generali di vendita**

## LEGENDA&SIMBOLOGIA /

LEGEND AND SYMBOLOLOGY / LÉGENDE ET SYMBOLOLOGIE / LEGENDE UND SYMBOLOLOGIE / LEYENDA Y SIMBOLOGÍA





### FINITURE DI SUPERFICIE/

SURFACE FINISHES / FINITIONS DE SURFACE / OBERFLÄCHENVEREDELUNGEN / ACABADOS SUPERFICIALES

 Natural	 Natural R9	 Natural R10	 Grip R10	 Structured R10
 Grip R11	 Structured R11	 R12	 Lappato	 Silky
 Glossy	 3D			









### VARIAZIONI CROMATICHE/

COLOUR VARIATIONS / VARIATION CHROMATIQUES / FARBUNTERSCHIEDE / VARIACIÓN CROMÁTICAS

 V0 Variazioni minime le differenze di tono tra i pezzi sono distinguibili ma simili / Minor variations, the differences of shade amongst pieces are visible but similar / Variations minimales, les différences de nuance entre les pièces sont visibles mais identiques / Minimale Variationen, die Farbunterschiede zwischen den einzelnen Stücken sind erkennbar, aber es besteht große Ähnlichkeit / Variaciones mínimas, las piezas presentan entre sí diferencias de tono distinguibles, pero son similares	 V1 Aspetto molto uniforme, i pezzi hanno lo stesso tono / Particularly even appearance, pieces have the same shade / Aspect très uniforme, les pièces présentent la même nuance / Äußerst gleichförmiges Aussehen, die Stücke haben denselben Farbton / Aspecto muy uniforme, las piezas tienen el mismo tono	 V2 Aspetto uniforme le differenze tra i pezzi sono minime / Even appearance, the differences of shade amongst pieces are minimal / Aspect uniforme, les différences de nuance entre les pièces sont minimales / Gleichförmiges Aussehen, die Unterschiede zwischen den einzelnen Stücken sind minimal / Aspecto uniforme, las diferencias de tono entre las piezas son mínimas	 V3 Variazioni moderate, le differenze di tono tra i pezzi sono significative / Moderate variations, the differences of shade amongst pieces are significant / Variations modérées, les différences de nuance entre les pièces sont significatives / Mäßige Variationen, die Farbunterschiede zwischen den einzelnen Stücken sind bedeutend / Variaciones moderadas, las diferencias de tono entre las piezas son significativas	 V4 Variazioni sostanziali di tono, differenza tra i pezzi molto accentuata / Substantial variations of shade, striking differences amongst pieces / Variations substantielles de nuance, très forte différence entre les pièces / Stärke Farbvariationen, die Unterschiede zwischen den einzelnen Stücken sind sehr markant / Variaciones sustanciales de tono, las diferencias de tono entre las piezas son muy acentuadas
--	---	--	---	---

### CARATTERISTICHE TECNICHE/

TECHNICAL CHARACTERISTICS / CARACTERISTIQUES TECHNIQUES / TECHNISCHE EIGENSCHAFTEN / CARACTERÍSTICAS TÉCNICAS

 Dimensioni ed aspetto / Dimensions and surface / Taille et apparence / Größe und Aussehen / Dimensiones y aspecto superficial	 Resistenza abrasione profonda / Deep abrasion resistance / Résistance à l'abrasion profonde / Tiefenverschleissbeständigkeit / Resistencia a la abrasión profunda	 Resistenza chimica / Chemical resistance / Résistance chimique / Chemische Resistenz / Resistencia química
 Assorbimento acqua / Water absorption / Absorption d'eau / Wasseraufnahme / Absorción de agua	 Resistenza shock termici / Thermal shock resistance / Résistance aux écarts de température / Widerstandsfähigkeit gegen Temperaturschwankungen / Resistencia a los cambios de temperatura	 Resistenza alle macchie / Stain resistance / Résistance aux taches / Fleckenfestigkeit / Resistencia a las manchas
 Resistenza a rottura / Breaking strength / Module de rupture / Bruchlast / Módulo de rotura	 Resistenza al gelo / Frost resistance / Résistance au gel / Frostwiderstandsfähigkeit / Resistencia al hielo	 Classificazione antiscivolo / Assessment of slip resistance / Résistance au glissement / Bestimmung der Rutschemmungsfähigkeit / Resistencia al resbalamiento









PEZZI SPECIALI  
TRIMS / PIECES SPECIALES / FORMTEILE / PIEZAS ESPECIALES

COLLEZIONI COLLECTIONS COLLECTIONS KOLLEKTIONEN COLECCIONES	SCALINO INCOLLATO GLUED STEP TREAD / NEZ DE MARCHE COLLÉ / GEKLEBTE STUFENPLATTE / PELDAÑO CON PERFIL PEGADO		ANGOLARE INCOLLATO GLUED CORNER STEP TREAD / CARREAU DE MARCHE COLLÉ PIÈCE ANGULAIRE / GEKLEBTE STUFENPLATTE ECKSTÜCK / PELDAÑO ESQUINA CON PERFIL PEGADO		TERMINALE L MONOLITICO L TERMINAL TEXTURED / TERMINALE ELLE STRUCTURÉ / STRUKTURIERTE L STÜCK FLIESE / REMATE EN FORMA DE L ESTRUCTURADO		TERMINALE L INCOLLATO GLUED L TERMINAL / TERMINALE ELLE COLLÉ / L STÜCK FLIESE GEKLEBT / REMATE EN FORMA DE L PEGADO					
	33x120 (13"x48")	30x120 (12"x48")	33x60 (13"x24")	30x60 (12"x24")	33x120 (13"x48")	30x120 (12"x48")	33x60 (13"x24")	33x33 (13"x13")	30x30 (12"x12")	30x15x4 (12"x6"x1 <sup>9</sup> / <sub>16</sub> ")	30x16,5x3,8 (12"x6 <sup>1</sup> / <sub>2</sub> "x1 <sup>9</sup> / <sub>16</sub> ")	30x15x4 (12"x6"x1 <sup>9</sup> / <sub>16</sub> ")
9CENTO	◆		◆		◆			◆				
ALPI										▲		
ARAN	■		■		■			■				
ARTEMIS	●		●		●			●				
BACK	●▲		●		●▲			●				
BEAT		●				●						
BRYSTONE	●		●		●			●				
CHORUS	●		●		●			●				
DOLMIX	●		●		●			●				
ELECTIC	◆×		◆×		◆×			◆×				
ELEMENTS DESIGN	●■		●■		●■			●■				
ELEMENTS LUX	●◆		●◆		●◆			●◆				
EVOKE		●				●						
GRANIGLIATI LINEA TECNICA												
IKON	●■		●■		●■			●■				
INTERNO4	●◆		●◆		●◆			●◆				
LIMES	■		■		■			■		▲		▲
MIDLAKE										▲		
MOOV	●		●		●			●				●
NOORD	■		■		■			■				
PERCORSI EXTRA	●■▲		●■▲		●■▲			●■▲		▲		●■▲
PERCORSI QUARTZ			●▲					●▲		▲		●▲
PERCORSI SMART			●▲					●▲		▲		●▲
SUNRISE												
UBIK	■		■		■			■				

COLLEZIONI COLLECTIONS COLLECTIONS KOLLEKTIONEN COLECCIONES	BATTISCOPIA BULLNOSE / PLINTHE / SOCKEL / RODAPIÉ		SCALINO MONOLITICO STEP TREAD TEXTURED / NEZ DE MARCHE STRUCTURÉ / STRUKTURIERTE STUFENPLATTE / PELDAÑO ESTRUCTURADO		SCALINO ANGOLARE MONOLITICO CORNER STEP TREAD TEXTURED / CARREAU DE MARCHE PIÈCE ANGULAIRE STRUCTURÉ / STRUKTURIERTE STUFENPLATTE ECKSTÜCK / PELDAÑO ESQUINA ESTRUCTURADO		GRADINO STEP TREAD / NEZ DE MARCHE / STUFENPLATTE / PELDAÑO					
	4,6x120 (1 <sup>9</sup> / <sub>16</sub> "x48")	7x80 (2 <sup>3</sup> / <sub>4</sub> "x32")	7,2x75 (2,8"x30")	7,2x60 (2,8"x24")	7,2x45,3 (2,8"x17 <sup>3</sup> / <sub>16</sub> ")	6,2x60 (2,4"x24")	10x30 (4"x12")	8x30 (3"x12")	30x33 (12"x13")	33x33 (13"x13")	30x30 (12"x12")	
9CENTO	◆				◆							
ALPI							▲		▲		▲	
ARAN	■				■							
ARTEMIS	●	●										
BACK					●							
BEAT						●						
BRYSTONE	●	●			●							
CHORUS			●		●							
DOLMIX	●				●							
ELECTIC					●◆×							
ELEMENTS DESIGN					●							
ELEMENTS LUX					●◆							
EVOKE					●							
GRANIGLIATI LINEA TECNICA												●
IKON					●							
INTERNO4	●◆	●◆										
LIMES					■▲	▲						
MIDLAKE						▲						
MOOV	●		●		●							●
NOORD	■	■			■							
PERCORSI EXTRA					●▲				▲		▲	
PERCORSI QUARTZ					●▲				▲		▲	
PERCORSI SMART					●▲							
SUNRISE					■							
UBIK	■				■							

specs & tech | trims



# K2 20mm / K3 30mm

PEZZI SPECIALI  
TRIMS / PIECES SPECIALES / FORMTEILE / PIEZAS ESPECIALES



COLLEZIONI COLLECTIONS COLLECTIONS KOLLEKTIONEN COLECCIONES	ANGOLARE BORDO CON TORO CORNER STEP TREAD / NEZ DE MARCHE ANGULAIRE / STUFENPLATTE ECKSTÜCK / ANGULAR CANTO ROMO	GRADINO BORDO CON TORO ROUNDED STEP TREAD / NEZ DE MARCHE ARRONDI / GERUNDET STUFENPLATTE / PELDAÑO CANTO ROMO	TOP TOP STEP TREAD / NEZ DE MARCHE HAUT / STUFENPLATTE TOP / TOP CANTO ROMO	CORDOLO L GLUED L TERMINAL / TERMINAL L COLLÉ / L STÜCK FLIESE GEKLEBT / TERMINAL L (PEGADO)	ANGOLARE GRIGLIA GRID / GRIL / GRILL / ANGULAR REJILLA	GRIGLIA GRID / GRIL / GRILL / REJILLA
---	---	--	---	--	--	---

40x40 (16"x16")	30x30 (12"x12")	60x120 (24"x48")	30x120 (12"x48")	45x90 (18"x36")	40x80 (16"x32")	30x60 (12"x24")	40x80 (16"x32")	30x60 (12"x24")	80x20x20 (32"x8"x8")	60x20x15 (24"x8"x6")	80x20 (32"x8")	60x15 (24"x6")	80x20 (32"x8")	60x15 (24"x6")
--------------------	--------------------	---------------------	---------------------	--------------------	--------------------	--------------------	--------------------	--------------------	-------------------------	-------------------------	-------------------	-------------------	-------------------	-------------------

### K2 20 mm

ARAN		▲	▲									▲		▲
ARTEMIS		▲	▲	▲		▲			▲				▲	
BACK		▲				▲			▲		▲			▲
BEAT														
BRYSTONE	▲	▲			▲	▲	▲	▲	▲	▲	▲	▲	▲	▲
CHORUS		▲	▲	▲		▲			▲			▲		▲
DOLMIX		▲	▲	▲		▲			▲			▲		▲
ELEMENT DESIGN			▲	▲								▲		▲
EVOKE				▲										
IKON		▲				▲			▲			▲		▲
LIMES		▲			▲	▲			▲			▲		▲
MIDLAKE		▲			▲	▲			▲			▲		▲
MOOV		▲				▲			▲			▲		▲
NOORD	▲	▲	▲	▲		▲	▲	▲	▲	▲	▲	▲	▲	▲
PERCORSI EXTRA	▲	▲	▲	▲	▲	▲	▲	▲	▲	▲	▲	▲	▲	▲
PERCORSI QUARTZ		▲				▲			▲			▲		▲
PERCORSI SMART		▲			▲	▲			▲			▲		▲
SIGHT		▲				▲			▲			▲		▲
SOUL				▲										
UBIK		▲	▲	▲		▲			▲					▲

				30x60 (12"x24")										
--	--	--	--	--------------------	--	--	--	--	--	--	--	--	--	--

### K3 30 mm

MOOV				▲										
PERCORDI EXTRA				▲										
PERCORSI SMART				▲										



GRADINO ANGOLO INTERNO BORDO CON TORO INT. CORNER STEP TREAD / ANGLE INT. NEZ DE MARCHE / INNENECKTRITTSTUFE / ANG. INT. CANTO ROMO	GRADINO ANGOLO ESTERNO BORDO CON TORO EXT. CORNER STEP TREAD / ANGLE EXT. NEZ DE MARCHE / AUSSENECKTRITTSTUFE / ANG. EXT. CANTO ROMO	TERMINALE L GLUED L TERMINAL / TERMINAL L COLLÉ / L STÜCK FLIESE GEKLEBT / TERMINAL L (PEGADO)
--	---	--

60x120 (24"x48")	30x120 (12"x48")	45x90 (18"x36")	40x40 (16"x16")	30x60 (12"x24")	60x120 (24"x48")	30x120 (12"x48")	45x90 (18"x36")	40x80 (16"x32")	30x60 (12"x24")	120x45x15 (48"x18"x6")	120x40x10 (48"x16"x4")	90x45x15 (36"x18"x6")	80x33x5 (32"x13"x2")	80x20x5 (32"x8"x2")	60x33x5 (24"x13"x2")	60x20x5 (24"x8"x2")
---------------------	---------------------	--------------------	--------------------	--------------------	---------------------	---------------------	--------------------	--------------------	--------------------	---------------------------	---------------------------	--------------------------	-------------------------	------------------------	-------------------------	------------------------

### K2 20 mm

	▲	▲				▲	▲				▲					▲
	▲	▲			▲	▲	▲		▲						▲	▲
					▲				▲						▲	▲
												▲				
			▲	▲				▲	▲				▲	▲	▲	▲
			▲	▲				▲	▲						▲	▲
			▲	▲				▲	▲						▲	▲
			▲	▲				▲	▲						▲	▲

				30x60 (12"x24")				30x60 (12"x24")								
--	--	--	--	--------------------	--	--	--	--------------------	--	--	--	--	--	--	--	--

### K3 30 mm

				▲				▲								
				▲				▲								
				▲				▲								

specs & tech | trims

▲ Grip R11 | ▲ Structured R11

# Contract

GAMMA 2021  
RANGE 2021 / GAMME 2021 / RANGE 2021 / GAMA 2021

COLLEZIONI COLLECTIONS COLLECTIONS KOLLEKTIONEN COLECCIONES	COLORI COLOURS COULEURS FARBE COLORES	60x120 24"x48"	60x60 24"x24"	30x60 12"x24"	30x30 12"x12"	15x30 6"x12"	45x90 18"x36"	60x60 24"x24"
	working size	596x1195	596x596	297x596	297x297	-	446x895	596x596
		9 mm	8,5 mm	8,5 mm	8,5 mm	8,5 mm	K2 20mm	
CODE	CODE IVORY	●	●	●				
	CODE BEIGE	●	●	●				
	CODE GREY	●	●	●				
	CODE ANTHRACITE	●	●	●				
DUNSTONE	DUNSTONE IVORY	●	●	●				
	DUNSTONE BEIGE	●	●	●				
	DUNSTONE GREY	●	●	●				
LONDALE	LONDALE SILVER	●	●	●				
	LONDALE BEIGE	●	●	●				
	LONDALE GREY	●	●	●				
SWISSTONE	SWISSTONE ANTHRACITE	■	■	■				▲
	SWISSTONE GREY	■	■	■				▲
	SWISSTONE TAUPE	■	■	■				▲
	SWISSTONE BEIGE	■	■	■				▲
EXTREME	EXTREME BEIGE						▲	▲
	EXTREME GREY						▲	▲
	EXTREME ANTHRACITE						▲	▲
POINT	POINT SILVER			▲	▲	▲		
	P. BEIGE MULTICOLOR			▲	▲	▲		
	P. GREY MULTICOLOR			▲	▲	▲		
	POINT SAND			▲	▲	▲		
SKYWALL	SKYWALL BEIGE							▲
	SKYWALL GREY							▲
URBAN	URBAN IVORY		■	■				
	URBAN GREY		■	■				
	URBAN ANTHRACITE		■	■				

## PEZZI SPECIALI TRIMS / PIECES SPECIALES / FORMTEILE / PIEZAS ESPECIALES

COLLEZIONI COLLECTIONS COLLECTIONS KOLLEKTIONEN COLECCIONES	BATTISCOPIA BULLNOSE / PLINTHE / SOCKEL / RODAPIÉ	SCALINO INCOLLATO GLUED STEP TREAD / NEZ DE MARCHE COLLÉ / GEKLEBTE STUFENPLATTE / PELDAÑO CON PERFIL PEGADO	ANGOLARE INCOLLATO GLUED CORNER STEP TREAD / CARREAU DE MARCHE COLLÉ PIÈCE ANGULAIRE / GEKLEBTE STUFENPLATTE ECKSTÜCK / PELDAÑO ESQUINA CON PERFIL PEGADO	TERMINALE L MONOLITICO L TERMINAL TEXTURED / TERMINALE ELLE STRUCTURÉ / STRUKTURIERTE L STÜCK FLIESE / REMATE EN FORMA DE L ESTRUCTURADO			
	7,2x60 (2,8"x24")	8x30 (3"x12")	33x120 (13"x48")	33x60 (13"x24")	33x120 (13"x48")	33x33 (13"x13")	30x16,5x3,8 (12"x6 1/2"x1 1/2")
CODE	●		●	●	●	●	
DUNSTONE	●		●	●	●	●	
LONDALE	●		●	●	●	●	
POINT		▲					▲
SWISSTONE	■		■	■	■	■	
URBAN	■						

## PEZZI SPECIALI K2 TRIMS / PIECES SPECIALES / FORMTEILE / PIEZAS ESPECIALES

COLLEZIONI COLLECTIONS COLLECTIONS KOLLEKTIONEN COLECCIONES	ANGOLARE BORDO CON TORO CORNER STEP TREAD / NEZ DE MARCHE ANGULAIRE / STUFENPLATTE ECKSTÜCK / ANGULAR CANTO ROMO	GRADINO BORDO CON TORO ROUNDED STEP TREAD / NEZ DE MARCHE ARRONDI / GERUNDET STUFENPLATTE / PELDAÑO CANTO ROMO	TOP TOP STEP TREAD / NEZ DE MARCHE HAUT / STUFENPLATTE TOP / TOP CANTO ROMO	GRADINO ANGOLO INTERNO BORDO CON TORO INT. CORNER STEP TREAD / ANGLE INT. NEZ DE MARCHE / INNENECKTRITTSSTUFE / ANG. INT. CANTO ROMO	GRADINO ANGOLO ESTERNO BORDO CON TORO EXT. CORNER STEP TREAD / ANGLE EXT. NEZ DE MARCHE / AUSSENECKTRITTSSTUFE / ANG. EXT. CANTO ROMO	CORDOLO L GLUED L TERMINAL / TERMINAL L COLLÉ / L STÜCK FLIESE GEKLEBT / TERMINAL L (PEGADO)	TERMINALE L GLUED L TERMINAL / TERMINAL L COLLÉ / L STÜCK FLIESE GEKLEBT / TERMINAL L (PEGADO)	ANGOLARE GRIGLIA GRID / GRIL / GRILL / ANGULAR REJILLA	GRIGLIA GRID / GRIL / GRILL / REJILLA			
	30x30 (12"x12")	45x90 (18"x36")	30x60 (12"x24")	30x60 (12"x24")	45x90 (18"x36")	30x60 (12"x24")	60x20x15 (24"x8"x6")	90x45x15 (36"x18"x6")	60x33x5 (24"x13"x2")	60x20x5 (24"x8"x2")	60x15 (24"x6")	60x15 (24"x6")
EXTREME	▲	▲	▲	▲	▲	▲	▲	▲	▲	▲	▲	▲
SKYWALL	▲		▲	▲		▲		▲	▲	▲	▲	▲
SWISSTONE	▲		▲	▲		▲		▲	▲	▲	▲	▲











● Natural R9 | ■ Grip R10 | ■ Structured R10 | ▲ Structured R11

COLLEZIONI COLLECTIONS COLLECTIONS KOLLEKTIONEN COLECCIONES		INDOOR	OUTDOOR
ARAN	■	60x120 (24"x48") - 30x120 (12"x48") - 60x60 (24"x24") - 30x60 (12"x24") - 9,7x60 (3 <sup>7/8</sup> "x24")	
	▲		30x60 (12"x24") - 60x120 <b>K2</b> (24"x48")
ARTEMIS	●	120x120 (48"x48") - 60x120 (24"x48") - 30x120 (12"x48") - 80x80 (32"x32") - 40x80 (16"x32")	
	▲		60x120 <b>K2</b> (24"x48") - 60x60 <b>K2</b> (24"x24")
BACK	●	120x120 (48"x48") - 60x120 (24"x48") - 60x60 (24"x24") - 30x60 (12"x24")	
	■	7,5x30 (3"x12")	
	▲		60x120 (24"x48") - 60x60 (24"x24") - 30x60 (12"x24") - 60x60 <b>K2</b> (24"x24")
	●	30x240 (12"x96") - 30x120 (12"x48") - 20x120 (8"x48")	
BEAT	■	20x120 (8"x48")	
	▲		40x120 <b>K2</b> (16"x48")
BRYSTONE	●	120x278 (48"x110") - 120x120 (48"x48") - 60x120 (24"x48") - 30x120 (12"x48") - 80x80 (32"x32") - 60x60 (24"x24") - 30x60 (12"x24") - 9,7x60 (37/8"x24")	
	■	60x120 (24"x48") - 60x60 (24"x24") - 30x60 (12"x24")	
	▲		60x90 <b>K2</b> (24"x36") - 80x80 <b>K2</b> (32"x32")
	●	120x120 (48"x48") - 60x120 (24"x48") - 30x120 (12"x48") - 75x75 (30"x30") - 37,5x75 (15"x30") - 60x60 (24"x24") - 30x60 (12"x24") - 9,7x60 (37/8"x24")	
CHORUS	●	60x120 (24"x48") - 60x60 (24"x24") - 30x60 (12"x24")	
	▲		60x120 (24"x48") - 60x60 (24"x24") - 30x60 (12"x24") - 60x120 <b>K2</b> (24"x48") - 60x60 <b>K2</b> (24"x24") - 30x60 <b>K2</b> (12"x24")
DOLMIX	●	120x278 (48"x110") - 120x120 (48"x48") - 60x120 (24"x48") - 60x60 (24"x24")	
	▲		120x120 <b>K2</b> (48"x48") - 60x60 <b>K2</b> (24"x24")
	●	120x278 (48"x110") - 120x120 (48"x48") - 60x120 (24"x48") - 20x120 (8"x48") - 60x60 (24"x24") - 30x60 (12"x24") - 9,7x60 (37/8"x24")	
	●	esagona 25x21,6 (10"x8 <sup>5/8</sup> ")	
ELEMENTS DESIGN	■	60x120 (24"x48") - 60x60 (24"x24") - 30x60 (12"x24")	
	▲		60x120 <b>K2</b> (24"x48")
	★	7,5x30 (3"x12")	
	◆	60x120 (24"x48") - 60x60 (24"x24")	
EVOKE	●	30x120 (12"x48") - 20x120 (8"x48") - 15x120 (6"x48")	
	▲		20x120 (8"x48") - 30x120 <b>K2</b> (12"x48")

COLLEZIONI COLLECTIONS COLLECTIONS KOLLEKTIONEN COLECCIONES		INDOOR	OUTDOOR
GRANIGLIATI - LINEA TECNICA	●	30x30 (12"x12")	
	+		30x30 (12"x12")
IKON	●	120x278 (48"x110") - 120x120 (48"x48") - 60x120 (24"x48") - 30x120 (12"x48") - 90x90 (36"x36") - 60x60 (24"x24")	
	■	120x120 (48"x48") - 60x120 (24"x48") - 30x120 (12"x48") - 60x60 (24"x24") - 30x60 (12"x24") - 9,7x60 (37/8"x24")	
	▲		30x60 (12"x24") - 90x90 <b>K2</b> (36"x36") - 60x60 <b>K2</b> (24"x24")
	■	60x120 (24"x48") - 60x60 (24"x24") - 30x60 (12"x24")	
LIMES	▲		30x60 (12"x24") - 22,5x45,3 (9"x18") - 22,5x22,5 (9"x9") - 60x90 <b>K2</b> (24"x36")
	●	120x278 (48"x110") - 120x240 (48"x96") - 120x120 (48"x48") - 60x120 (24"x48") - 30x120 (12"x48") - 20x120 (8"x48") - 75x75 (30"x30") - 60x60 (24"x24") - 30x60 (12"x24") - 14,7x60 (5 <sup>3/4</sup> "x24") - 9,7x60 (37/8"x24") - 6,4x60 (3 <sup>1/2</sup> "x24") - 3,1x60 (1 <sup>1/4</sup> "x24") - 45x45 (18"x18")	
MOOV	■	7,5x30 (3"x12")	
	■	120x120 (48"x48") - 60x120 (24"x48") - 60x60 (24"x24") - 30x60 (12"x24")	
	▲		60x120 (24"x48") - 60x60 (24"x24") - 30x60 (12"x24") - 120x120 <b>K2</b> (48"x48") - 90x90 <b>K2</b> (36"x36") - 60x60 <b>K2</b> (24"x24") - 60x60 <b>K3</b> (24"x24")
	●	120x120 (48"x48") - 60x120 (24"x48") - 30x120 (12"x48") - 80x80 (32"x32") - 60x60 (24"x24") - 30x60 (12"x24") - 9,7x60 (37/8"x24")	
NOORD	▲		120x120 <b>K2</b> (48"x48") - 80x80 <b>K2</b> (32"x32") - 60x60 <b>K2</b> (24"x24") - 30x60 <b>K2</b> (12"x24")
	●	60x120 (24"x48") - 60x60 (24"x24") - 30x60 (12"x24")	
PERCORSI EXTRA	■	60x120 (24"x48") - 60x60 (24"x24") - 30x60 (12"x24")	
	▲		60x120 (24"x48") - 60x60 (24"x24") - 30x60 (12"x24") - 120x240 <b>K2</b> (48"x96") - 120x120 <b>K2</b> (48"x48") - 60x120 <b>K2</b> (24"x48") - 30x120 <b>K2</b> (12"x48") - 45x90 <b>K2</b> (18"x36") - 80x80 <b>K2</b> (32"x32") - 60x60 <b>K2</b> (24"x24") - 60x60 <b>K3</b> (24"x24")
PERCORSI QUARTZ	●	60x60 (24"x24") - 30x60 (12"x24")	
	▲		60x60 (24"x24") - 30x60 (12"x24") - 60x60 <b>K2</b> (24"x24")
PERCORSI SMART	●	60x60 (24"x24") - 30x60 (12"x24")	
	▲		60x60 (24"x24") - 30x60 (12"x24") - 15x30 (6"x12") - 120x240 <b>K2</b> (48"x96") - 30x240 <b>K2</b> (12"x96") - 120x120 <b>K2</b> (48"x48") - 45x90 <b>K2</b> (18"x36") - 60x60 <b>K2</b> (24"x24") - 60x60 <b>K3</b> (24"x24")
SWISSSTONE CONTRACT	■	60x120 (24"x48") - 60x60 (24"x24") - 30x60 (12"x24")	
	▲		60x60 <b>K2</b> (24"x24")
UBIK	●	120x120 (48"x48") - 60x120 (24"x48") - 30x120 (12"x48") - 60x60 (24"x24") - 30x60 (12"x24") - 9,7x60 (37/8"x24")	
	▲		30x60 (12"x24") - 60x120 <b>K2</b> (24"x48") - 60x60 <b>K2</b> (24"x24")

## INFORMAZIONI TECNICHE











TECHNICAL FEATURES / INFORMATIONS TECHNIQUES / TECHNISCHE INFORMATIONEN / INFORMACIÓN TÉCNICA

DESCRIZIONE DESCRIPTION / DESCRIPTION BESCHREIBUNG / DESCRIPCIÓN	NORME REGULATION / NORME / NORM / NORMA	REQUISITI PRESCRITTI REQUIRED VALUES / EXIGENCES RÉGLEMENTAIRES / VORGE- SCHRIEBENE ANFORDERUNGEN / REQUISITOS ESTABLECIDOS
	EN 14411 - ISO 13006	
	<b>DIMENSIONI RETTIFICATO</b> SIZES RECTIFIED / FORMAT RECTIFIÉ / ABMESSUNGEN NACH DEM SCHLEIFEN / TAMAÑO RECTIFICADO	UNI EN ISO 10545-2  lunghezza-larghezza ±0,3% (±1,0 mm max) <i>length-width / longueur-largeur / Länge-Breite / longitud-ancho</i> spessore ±5,0% (±0,5 mm max) <i>thickness / épaisseur / Stärke / espesor</i> ortogonalità ±0,3% (±1,5 mm max) <i>rectangularity / orthogonalité / Rechtwinkligkeit / ortogonalidad</i> rettilinearità ±0,3% (±0,8 mm max) <i>straightness / rectilignité / Geradlinigkeit / rectilíneidad</i> planarità ±0,4% (±1,8 mm max) <i>surface flatness / planéité / Ebenflächigkeit / planaridad</i> qualità superficie ≥95% <i>surface quality / qualités surface / Oberflächenbeschaffenheit / cualidades superficie</i>
	<b>DIMENSIONI NON RETTIFICATO</b> SIZES NOT RECTIFIED / FORMAT NON RECTIFIÉ / ABMESSUNGEN VOR DEM SCHLEIFEN / TAMAÑO NO RECTIFICADO	UNI EN ISO 10545-2  lunghezza-larghezza ±0,6% (±2,0 mm max) <i>length-width / longueur-largeur / Länge-Breite / longitud-ancho</i> spessore ±5,0% (±0,5 mm max) <i>thickness / épaisseur / Stärke / espesor</i> ortogonalità ±0,5% (±2,0 mm max) <i>rectangularity / orthogonalité / Rechtwinkligkeit / ortogonalidad</i> rettilinearità ±0,5% (±1,5 mm max) <i>straightness / rectilignité / Geradlinigkeit / rectilíneidad</i> planarità ±0,5% (±2,0 mm max) <i>surface flatness / planéité / Ebenflächigkeit / planaridad</i> qualità superficie ≥95% <i>surface quality / qualités surface / Oberflächenbeschaffenheit / cualidades superficie</i>
	<b>ASSORBIMENTO ACQUA</b> WATER ABSORPTION / ABSORPTION D'EAU / WASSERAUFNAHME / ABSORCIÓN DE AGUA	UNI EN ISO 10545-3  ≤0,5%
	<b>RESISTENZA A ROTTURA</b> BREAKING STRENGHT / RESISTANCE À LA RUPTURE / BRUCHFESTIGKEIT / RESISTENCIA A LA ROTURA	UNI EN ISO 10545-4  R≥35 N/mm <sup>2</sup> S≥700 N (<7,5 mm) S≥1300 N (≥7,5 mm)
	<b>RESISTENZA ABRASIONE PROFONDA (UGL - Matt)</b> DEEP ABRASION RESISTANCE (UGL - Matt) / RÉSISTANCE À L'ABRASION PROFONDE (UGL - Matt) / TIEFENVERSCHLEISSBESTÄNDIGKEIT (UGL - Matt) / RESISTENCIA A LA ABRASIÓN PROFUNDA (UGL - Matt)	UNI EN ISO 10545-6  ≤175 mm <sup>3</sup>
	<b>RESIST. ABRASIONE SUPERFICIALE (GL - Lappato / Silky)</b> SURFACE ABRASION RESISTANCE (GL - Lappato / Silky) / RESIST. À L'ABRASION SUPERFICIELLE (GL - Roadé / Silky) / WIDERSTÄNDIGKEIT GEGEN OBERFLÄCHENVERSCHLEISS (GL - geläppt / silky) / RESIST. ABRASIÓN SUPERFICIAL (GL: esmaltado / Silky)	UNI EN ISO 10545-6  dichiarare un valore / declare a value / déclarer une valeur / einen Wert angeben / declarar un valor
	<b>RESISTENZA SHOCK TERMICI</b> THERMAL SHOCK RESISTANCE / RESISTANCE AUX ÉCARTS DE TEMPÉRATURE / WIDERSTANDSFÄHIGKEIT GEGEN TEMPERATURSCHWANKUNGEN / RESISTENCIA A LOS CAMBIOS DE TEMPERATURA	UNI EN ISO 10545-9  resistenza / resistant / résistance / Widerständigkeit / resistencia
	<b>RESISTENZA AL GELO</b> FROST RESISTANCE / RESISTANCE AU GEL / FROSTWIDERSTANDSFÄHIGKEIT / RESISTENCIA AL HIELO	UNI EN ISO 10545-12  resistenza / resistant / résistance / Widerständigkeit / resistencia
	<b>RESISTENZA CHIMICA</b> CHEMICAL RESISTANCE / RESISTANCE CHIMIQUE CHEMISCHE BESTÄNDIGKEIT / RESISTENCIA QUÍMICA	UNI EN ISO 10545-13  resistenza / resistant / résistance / Widerständigkeit / resistencia
	<b>RESISTENZA ALLE MACCHIE</b> STAIN RESISTANCE / RESISTANCE AUX TACHES / FLECKENFESTIGKEIT / RESISTENCIA A LAS MANCHAS	UNI EN ISO 10545-14  pulibile / cleanable / nettoyable / kann gereinigt werden / lavable
	DIN 51130	R
	DIN 51097	A+B+C
	<b>CLASSIFICAZIONE ANTISDRUCCIOLO</b> ASSESSMENT OF SLIP RESISTANCE / CLASSIFICATION ANTIGLISSE RUTSCHFESTIGKEITSKLASSECLASIFICACIÓN ANTIDESLIZANTE	B.C.R.A. (COF)  ANSI A137.1 2012 (DCOF)  BS 7976-2:2002 (UK) (Pendulum Test Value)
		>0,40 bagnato / wet  >0,42 bagnato / wet  0-24 scivoloso / slippery / glissant / Rutschig / resbaladizo 25-35 scivolosità moderata / moderately slippery / glissance modérée / mäßige Rutschgefahr / Deslizamiento moderado >36 basso rischio scivolamento / low slipping risk / risque de glissement faible / geringe Rutschgefahr / bajo riesgo de deslizamiento

Piastrelle pressate a secco - Conforme alla norma EN 14411 e ISO 13006 appendice G gruppo B1-a con E ≤0,5%

Dry pressed tiles - Compliant with standards EN 14411 and ISO 13006 annex G group B1-a with E ≤0,5% / Carreau pressé à sec - Conforme à la norme EN 14411 et ISO 13006 annexe G groupe B1-a avec E ≤0,5% / Trocken gepresste Fliesen - Erfüllen die Anforderungen der Norm en 14411 und ISO 13006 Anhang g Gruppe B1-a mit E ≤0,5% / Baldosas prensadas en seco - Conforme a las normas en 14411 e iso 13006, anexo g grupo B1-a con E ≤0,5 %









332/333

VALORI VALUES / VALEURS WERTE / VALORES	VALORI VALUES / VALEURS WERTE / VALORES	VALORI VALUES / VALEURS WERTE / VALORES	VALORI VALUES / VALEURS WERTE / VALORES
9CENTO	ALPI	ARAN	ARTEMIS
	<b>CONFORME</b> COMPLIANT / CONFORME ANFORDERUNGEN ERFÜLLT / CONFORME	-	<b>CONFORME</b> COMPLIANT / CONFORME ANFORDERUNGEN ERFÜLLT / CONFORME
	-	<b>CONFORME</b> COMPLIANT / CONFORME ANFORDERUNGEN ERFÜLLT / CONFORME	-
	≤0,1%	≤0,1%	≤0,1%
	6 mm R≥40 N/mm <sup>2</sup> S≥1000 N	9 mm R≥40 N/mm <sup>2</sup> S≥1500 N	9 mm R≥40 N/mm <sup>2</sup> S≥1500 N
	≤150 mm <sup>3</sup>	≤150 mm <sup>3</sup>	≤150 mm <sup>3</sup>
	<b>TEST DISPONIBILE</b> TEST AVAILABLE / TEST DISPONIBLE / TEST VERFÜGBAR / PRUEBA DISPONIBLE	-	<b>CONFORME</b> COMPLIANT / CONFORME ANFORDERUNGEN ERFÜLLT / CONFORME
	<b>CONFORME</b> COMPLIANT / CONFORME ANFORDERUNGEN ERFÜLLT / CONFORME	<b>CONFORME</b> COMPLIANT / CONFORME ANFORDERUNGEN ERFÜLLT / CONFORME	<b>CONFORME</b> COMPLIANT / CONFORME ANFORDERUNGEN ERFÜLLT / CONFORME
	<b>CONFORME</b> COMPLIANT / CONFORME ANFORDERUNGEN ERFÜLLT / CONFORME	<b>CONFORME</b> COMPLIANT / CONFORME ANFORDERUNGEN ERFÜLLT / CONFORME	<b>CONFORME</b> COMPLIANT / CONFORME ANFORDERUNGEN ERFÜLLT / CONFORME
	<b>CONFORME</b> COMPLIANT / CONFORME ANFORDERUNGEN ERFÜLLT / CONFORME	<b>CONFORME</b> COMPLIANT / CONFORME ANFORDERUNGEN ERFÜLLT / CONFORME	<b>CONFORME</b> COMPLIANT / CONFORME ANFORDERUNGEN ERFÜLLT / CONFORME
	<b>CONFORME</b> COMPLIANT / CONFORME ANFORDERUNGEN ERFÜLLT / CONFORME	<b>CONFORME</b> COMPLIANT / CONFORME ANFORDERUNGEN ERFÜLLT / CONFORME	<b>CONFORME</b> COMPLIANT / CONFORME ANFORDERUNGEN ERFÜLLT / CONFORME
	Lappato	R11 30x30 Not RT - 15x30 Not RT - 15x15 Not RT	R10 60x120 - 30x120 - 60x60 - 30x60 - 9,7x60 R11 30x60 - 60x120 K2
	<b>CONFORME</b> COMPLIANT / CONFORME ANFORDERUNGEN ERFÜLLT / CONFORME	<b>CONFORME</b> COMPLIANT / CONFORME ANFORDERUNGEN ERFÜLLT / CONFORME	<b>CONFORME</b> COMPLIANT / CONFORME ANFORDERUNGEN ERFÜLLT / CONFORME
	<b>CONFORME</b> COMPLIANT / CONFORME ANFORDERUNGEN ERFÜLLT / CONFORME	<b>CONFORME</b> COMPLIANT / CONFORME ANFORDERUNGEN ERFÜLLT / CONFORME	<b>CONFORME</b> COMPLIANT / CONFORME ANFORDERUNGEN ERFÜLLT / CONFORME
	-	-	>36 60x120 - 30x120 - 60x60 - 30x60 - 9,7x60 Grey/Silver/Anthracite/Walnut
	-	-	in test



## INFORMAZIONI TECNICHE











TECHNICAL FEATURES / INFORMATIONS TECHNIQUES / TECHNISCHE INFORMATIONEN / INFORMACIÓN TÉCNICA

DESCRIZIONE DESCRIPTION / DESCRIPTION BESCHREIBUNG / DESCRIPCIÓN	VALORI VALUES / VALEURS WERTE / VALORES	VALORI VALUES / VALEURS WERTE / VALORES	
	BACK	BEAT	
	<b>DIMENSIONI RETTIFICATO</b> SIZES RECTIFIED / FORMAT RECTIFIÉ / ABMESSUNGEN NACH DEM SCHLEIFEN / TAMAÑO RECTIFICADO	<b>CONFORME</b> COMPLIANT / CONFORME ANFORDERUNGEN ERFÜLLT / CONFORME	<b>CONFORME</b> COMPLIANT / CONFORME ANFORDERUNGEN ERFÜLLT / CONFORME
	<b>DIMENSIONI NON RETTIFICATO</b> SIZES NOT RECTIFIED / FORMAT NON RECTIFIÉ / ABMESSUNGEN VOR DEM SCHLEIFEN / TAMAÑO NO RECTIFICADO	<b>CONFORME</b> COMPLIANT / CONFORME ANFORDERUNGEN ERFÜLLT / CONFORME 7,5x30	–
	<b>ASSORBIMENTO ACQUA</b> WATER ABSORPTION / ABSORPTION D'EAU / WASSERAUFNAHME / ABSORCIÓN DE AGUA	≤0,1%	≤0,1%
	<b>RESISTENZA A ROTTURA</b> BREAKING STRENGHT / RESISTANCE À LA RUPTURE / BRUCHFESTIGKEIT / RESISTENCIA A LA ROTURA	<b>9 mm</b> R≥40 N/mm <sup>2</sup> S≥1500 N	<b>20 mm</b> R≥45 N/mm <sup>2</sup> S≥10000 N
	<b>RESISTENZA ABRASIONE PROFONDA (UGL - Matt)</b> DEEP ABRASION RESISTANCE (UGL - Matt) / RESISTANCE À L'ABRASION PROFONDE (UGL - Matt) / TIEFENVERSCHLEISSBESTÄNDIGKEIT (UGL - Matt) / RESISTENCIA A LA ABRASIÓN PROFUNDA (UGL - Matt)	≤150 mm <sup>3</sup>	≤150 mm <sup>3</sup>
	<b>RESIST. ABRASIONE SUPERFICIALE (GL - Lappato / Silky)</b> SURFACE ABRASION RESISTANCE (GL - Lappato / Silky) / RESIST. A L'ABRASION SUPERFICIELLE (GL - Rodé / Silky) / WIDERSTÄNDIGKEIT GEGEN OBERFLÄCHENVERSCHLEISS (GL - geläppt / silky) / RESIST. ABRASIÓN SUPERFICIAL (GL - esmaltado / Silky)	–	–
	<b>RESISTENZA SHOCK TERMICI</b> THERMAL SHOCK RESISTANCE / RESISTANCE AUX ÉCARTS DE TEMPÉRATURE / WIDERSTANDSFÄHIGKEIT GEGEN TEMPERATURSCHWANKUNGEN / RESISTENCIA A LOS CAMBIOS DE TEMPERATURA	<b>CONFORME</b> COMPLIANT / CONFORME ANFORDERUNGEN ERFÜLLT / CONFORME	<b>CONFORME</b> COMPLIANT / CONFORME ANFORDERUNGEN ERFÜLLT / CONFORME
	<b>RESISTENZA AL GELO</b> FROST RESISTANCE / RESISTANCE AU GEL / FROSTWIDERSTANDSFÄHIGKEIT / RESISTENCIA AL HIELO	<b>CONFORME</b> COMPLIANT / CONFORME ANFORDERUNGEN ERFÜLLT / CONFORME	<b>CONFORME</b> COMPLIANT / CONFORME ANFORDERUNGEN ERFÜLLT / CONFORME
	<b>RESISTENZA CHIMICA</b> CHEMICAL RESISTANCE / RESISTANCE CHIMIQUE CHEMISCHE BESTÄNDIGKEIT / RESISTENCIA QUÍMICA	<b>CONFORME</b> COMPLIANT / CONFORME ANFORDERUNGEN ERFÜLLT / CONFORME	<b>CONFORME</b> COMPLIANT / CONFORME ANFORDERUNGEN ERFÜLLT / CONFORME
	<b>RESISTENZA ALLE MACCHIE</b> STAIN RESISTANCE / RESISTANCE AUX TACHES / FLECKENFESTIGKEIT / RESISTENCIA A LAS MANCHAS	<b>CONFORME</b> COMPLIANT / CONFORME ANFORDERUNGEN ERFÜLLT / CONFORME	<b>CONFORME</b> COMPLIANT / CONFORME ANFORDERUNGEN ERFÜLLT / CONFORME
	<b>R9</b> 120x120 - 60x120 - 60x60 - 30x60 <b>R10</b> 7,5x30 Not RT <b>R11</b> 60x120 - 60x60 - 30x60 - 60x60 K2	<b>R9</b> 30x240 - 30x120 - 20x120 <b>R10</b> 20x120 <b>R11</b> 40x120 K2	
	<b>CLASSIFICAZIONE ANTISDRUCCIOLO</b> ASSESSMENT OF SLIP RESISTANCE / CLASSIFICATION ANTIGLISSE RUTSCHFESTIGKEITSKLASSE/CLASIFICACIÓN ANTIDESLIZANTE	<b>A+B</b> Natural R9 <b>A+B+C</b> Grip R11-Structured R10	<b>A</b> Natural R9 / <b>A+B</b> Grip R10 / <b>A+B+C</b> Structured R11
	<b>CONFORME</b> COMPLIANT / CONFORME ANFORDERUNGEN ERFÜLLT / CONFORME	<b>CONFORME</b> COMPLIANT / CONFORME ANFORDERUNGEN ERFÜLLT / CONFORME	<b>CONFORME</b> COMPLIANT / CONFORME ANFORDERUNGEN ERFÜLLT / CONFORME
	<b>CONFORME</b> COMPLIANT / CONFORME ANFORDERUNGEN ERFÜLLT / CONFORME	<b>CONFORME</b> COMPLIANT / CONFORME ANFORDERUNGEN ERFÜLLT / CONFORME	<b>CONFORME</b> COMPLIANT / CONFORME ANFORDERUNGEN ERFÜLLT / CONFORME
	–	> <b>36</b> 20x120 Brown/Ivory/Grey/Taupe/Walnut	

Piastrelle pressate a secco - Conforme alla norma EN 14411 e ISO 13006 appendice G gruppo B1-a con E ≤0,5%











Dry pressed tiles - Compliant with standards EN 14411 and ISO 13006 annex G group B1-a with E ≤0,5% / Carreau pressé à sec - Conforme à la norme EN 14411 et ISO 13006 annexe g groupe B1-a avec E ≤0,5% / Trocken gepresste Fliesen - Erfüllen die Anforderungen der Norm en 14411 und ISO 13006 Anhang g Gruppe B1-a mit E ≤0,5% / Baldosas prensadas en seco - Conforme a las normas en 14411 e iso 13006, anexo g grupo B1-a con E ≤0,5 %

334/335

VALORI VALUES / VALEURS WERTE / VALORES	VALORI VALUES / VALEURS WERTE / VALORES	VALORI VALUES / VALEURS WERTE / VALORES	VALORI VALUES / VALEURS WERTE / VALORES
BRYSTONE	CHORUS	DOLMIX	ECLECTIC
	<b>CONFORME</b> COMPLIANT / CONFORME ANFORDERUNGEN ERFÜLLT / CONFORME	<b>CONFORME</b> COMPLIANT / CONFORME ANFORDERUNGEN ERFÜLLT / CONFORME	<b>CONFORME</b> COMPLIANT / CONFORME ANFORDERUNGEN ERFÜLLT / CONFORME
	–	–	–
	≤0,1%	≤0,1%	≤0,1%
	<b>6 mm</b> R≥40 N/mm <sup>2</sup> S≥1000 N	<b>9 mm</b> R≥40 N/mm <sup>2</sup> S≥1500 N	<b>20 mm</b> R≥45 N/mm <sup>2</sup> S≥10000 N
	≤150 mm <sup>3</sup>	≤150 mm <sup>3</sup>	≤150 mm <sup>3</sup>
	–	–	<b>TEST DISPONIBILE</b> TEST AVAILABLE / TEST DISPONIBLE / TEST VERFÜGBAR / PRUEBA DISPONIBLE
	<b>CONFORME</b> COMPLIANT / CONFORME ANFORDERUNGEN ERFÜLLT / CONFORME	<b>CONFORME</b> COMPLIANT / CONFORME ANFORDERUNGEN ERFÜLLT / CONFORME	<b>CONFORME</b> COMPLIANT / CONFORME ANFORDERUNGEN ERFÜLLT / CONFORME
	<b>CONFORME</b> COMPLIANT / CONFORME ANFORDERUNGEN ERFÜLLT / CONFORME	<b>CONFORME</b> COMPLIANT / CONFORME ANFORDERUNGEN ERFÜLLT / CONFORME	<b>CONFORME</b> COMPLIANT / CONFORME ANFORDERUNGEN ERFÜLLT / CONFORME
	<b>CONFORME</b> COMPLIANT / CONFORME ANFORDERUNGEN ERFÜLLT / CONFORME	<b>CONFORME</b> COMPLIANT / CONFORME ANFORDERUNGEN ERFÜLLT / CONFORME	<b>CONFORME</b> COMPLIANT / CONFORME ANFORDERUNGEN ERFÜLLT / CONFORME
	<b>CONFORME</b> COMPLIANT / CONFORME ANFORDERUNGEN ERFÜLLT / CONFORME	<b>CONFORME</b> COMPLIANT / CONFORME ANFORDERUNGEN ERFÜLLT / CONFORME	<b>CONFORME</b> COMPLIANT / CONFORME ANFORDERUNGEN ERFÜLLT / CONFORME
	<b>R9</b> 120x278 - 120x120 - 60x120 - 30x120 - 80x80 - 60x60 - 30x60 - 9,7x60 <b>R10</b> 60x120 - 60x60 - 30x60 <b>R10</b> 60x120 - 60x60 - 30x60 <b>R11</b> 60x90 K2 - 80x80 K2	<b>R9</b> 120x120 - 60x120 - 30x120 - 75x75 37,5x75 - 60x60 - 30x60 - 9,7x60 <b>R10</b> 60x120 - 60x60 - 30x60 <b>R11</b> 60x120 - 60x60 - 30x60 - 60x120 K2 - 60x60 K2 - 30x60 K2	<b>R9</b> 120x278 - 120x120 - 60x120 - 60x60 <b>Silky</b> 120x278 - 120x120 - 60x120 - 30x120 - 60x60 - 30x60 <b>R9</b> 60x120 - 60x60 - 30x60
	<b>A</b> Natural R9 / <b>A+B</b> Structured R10 <b>A+B+C</b> Structured R11	<b>A</b> Natural R9 / <b>A+B</b> Natural R10 <b>A+B+C</b> Grip R11	<b>A</b> Natural R9 <b>A+B+C</b> Structured R11
	<b>CONFORME</b> COMPLIANT / CONFORME ANFORDERUNGEN ERFÜLLT / CONFORME	<b>CONFORME</b> COMPLIANT / CONFORME ANFORDERUNGEN ERFÜLLT / CONFORME	<b>CONFORME</b> COMPLIANT / CONFORME ANFORDERUNGEN ERFÜLLT / CONFORME
	<b>CONFORME</b> COMPLIANT / CONFORME ANFORDERUNGEN ERFÜLLT / CONFORME	<b>CONFORME</b> COMPLIANT / CONFORME ANFORDERUNGEN ERFÜLLT / CONFORME	<b>CONFORME</b> COMPLIANT / CONFORME ANFORDERUNGEN ERFÜLLT / CONFORME
	> <b>36</b> 60x120 - 60x60 - 30x60 White/Ivory/Gold/Avana	> <b>36</b> 60x120 - 60x60 - 30x60 Tobacco/Silver/Beige/Grey/White	–

# INFORMAZIONI TECNICHE















TECHNICAL FEATURES / INFORMATIONS TECHNIQUES / TECHNISCHE INFORMATIONEN / INFORMACIÓN TÉCNICA

DESCRIZIONE DESCRIPTION / DESCRIPTION BESCHREIBUNG / DESCRIPCIÓN	VALORI VALUES / VALEURS WERTE / VALORES	VALORI VALUES / VALEURS WERTE / VALORES
	ELEMENTS DESIGN	ELEMENTS LUX
 <b>DIMENSIONI RETTIFICATO</b> SIZES RECTIFIED / FORMAT RECTIFIÉ / ABMESSUNGEN NACH DEM SCHLEIFEN / TAMAÑO RECTIFICADO	<b>CONFORME</b> COMPLIANT / CONFORME ANFORDERUNGEN ERFÜLLT / CONFORME	<b>CONFORME</b> COMPLIANT / CONFORME ANFORDERUNGEN ERFÜLLT / CONFORME
 <b>DIMENSIONI NON RETTIFICATO</b> SIZES NOT RECTIFIED / FORMAT NON RECTIFIÉ / ABMESSUNGEN VOR DEM SCHLEIFEN / TAMAÑO NO RECTIFICADO	<b>CONFORME</b> COMPLIANT / CONFORME ANFORDERUNGEN ERFÜLLT / CONFORME 7,5x30 - exa	-
 <b>ASSORBIMENTO ACQUA</b> WATER ABSORPTION / ABSORPTION D'EAU / WASSERAUFNAHME / ABSORCIÓN DE AGUA	≤0,1%	≤0,1%
 <b>RESISTENZA A ROTTURA</b> BREAKING STRENGHT / RESISTANCE À LA RUPTURE / BRUCHFESTIGKEIT / RESISTENCIA A LA ROTURA	6 mm    9 mm    20 mm R≥40 N/mm <sup>2</sup> R≥40 N/mm <sup>2</sup> R≥45 N/mm <sup>2</sup> S≥1000 N    S≥1500 N    S≥10000 N	6 mm    9 mm R≥40 N/mm <sup>2</sup> R≥40 N/mm <sup>2</sup> S≥1000 N    S≥1500 N
 <b>RESISTENZA ABRASIONE PROFONDA (UGL - Matt)</b> DEEP ABRASION RESISTANCE (UGL - Matt) / RESISTANCE À L'ABRASION PROFONDE (UGL - Matt) / TIEFENVERSCHLEISSBESTÄNDIGKEIT (UGL - Matt) / RESISTENCIA A LA ABRASIÓN PROFUNDA (UGL - Matt)	≤150 mm <sup>3</sup>	≤150 mm <sup>3</sup>
 <b>RESIST. ABRASIONE SUPERFICIALE (GL - Lappato / Silky)</b> SURFACE ABRASION RESISTANCE (GL - Lappato / Silky) / RESIST. A ABRASION SUPERFICIELLE (GL - Rodé / Silky) / WIDERSTÄNDIGKEIT GEGEN OBERFLÄCHENVERSCHLEISS (GL - geläppt / silky) / RESIST. ABRASIÓN SUPERFICIAL (GL: esmaltado / Silky)	<b>TEST DISPONIBILE</b> TEST AVAILABLE / TEST DISPONIBLE / TEST VERFÜGBAR / PRUEBA DISPONIBLE	<b>TEST DISPONIBILE</b> TEST AVAILABLE / TEST DISPONIBLE / TEST VERFÜGBAR / PRUEBA DISPONIBLE
 <b>RESISTENZA SHOCK TERMICI</b> THERMAL SHOCK RESISTANCE / RESISTANCE AUX ÉCARTS DE TEMPÉRATURE / WIDERSTANDSFÄHIGKEIT GEGEN TEMPERATURSCHWANKUNGEN / RESISTENCIA A LOS CAMBIOS DE TEMPERATURA	<b>CONFORME</b> COMPLIANT / CONFORME ANFORDERUNGEN ERFÜLLT / CONFORME	<b>CONFORME</b> COMPLIANT / CONFORME ANFORDERUNGEN ERFÜLLT / CONFORME
 <b>RESISTENZA AL GELO</b> FROST RESISTANCE / RESISTANCE AU GEL / FROSTWIDERSTANDSFÄHIGKEIT / RESISTENCIA AL HIELO	<b>CONFORME</b> COMPLIANT / CONFORME ANFORDERUNGEN ERFÜLLT / CONFORME	<b>CONFORME</b> COMPLIANT / CONFORME ANFORDERUNGEN ERFÜLLT / CONFORME
 <b>RESISTENZA CHIMICA</b> CHEMICAL RESISTANCE / RESISTANCE CHIMIQUE CHEMISCHE BESTÄNDIGKEIT / RESISTENCIA QUÍMICA	<b>CONFORME</b> COMPLIANT / CONFORME ANFORDERUNGEN ERFÜLLT / CONFORME	<b>CONFORME</b> COMPLIANT / CONFORME ANFORDERUNGEN ERFÜLLT / CONFORME
 <b>RESISTENZA ALLE MACCHIE</b> STAIN RESISTANCE / RESISTANCE AUX TACHES / FLECKENFESTIGKEIT / RESISTENCIA A LAS MANCHAS	<b>CONFORME</b> COMPLIANT / CONFORME ANFORDERUNGEN ERFÜLLT / CONFORME	<b>CONFORME</b> COMPLIANT / CONFORME ANFORDERUNGEN ERFÜLLT / CONFORME
 <b>CLASSIFICAZIONE ANTISDRUCCIOLO</b> ASSESSMENT OF SLIP RESISTANCE / CLASSIFICATION ANTIGLISSE RUTSCHFESTIGKEITSKLASSECLASIFICACIÓN ANTIDESLIZANTE	<b>Natural</b> exa Not RT / <b>Glossy</b> 7,5x30 Not RT / <b>Lappato</b> 60x120 - 60x60 <b>R9</b> 120x120 - 60x120 - 20x120 - 60x60 - 30x60 - 9,7x60 / <b>R10</b> 60x120 - 60x60 - 30x60 / <b>R11</b> 60x120 K2  - Natural / - Glossy / - Lappato / <b>A</b> Natural R9 / <b>A+B</b> Structured R10 / <b>A+B+C</b> Structured R11	<b>Lappato</b> 120x278 - 120x240 - 120x120 - 60x120 - 20x120 - 60x60 - 30x60 <b>R9</b> 60x120 - 60x60 - 30x60  - Lappato / <b>A</b> Natural R9
	<b>CONFORME (NO EXA / NO LAPP)</b> COMPLIANT / CONFORME ANFORDERUNGEN ERFÜLLT / CONFORME	<b>CONFORME (NO LAPPATO)</b> COMPLIANT / CONFORME ANFORDERUNGEN ERFÜLLT / CONFORME
	<b>CONFORME (NO EXA / NO LAPP)</b> COMPLIANT / CONFORME ANFORDERUNGEN ERFÜLLT / CONFORME	<b>CONFORME (NO LAPPATO)</b> COMPLIANT / CONFORME ANFORDERUNGEN ERFÜLLT / CONFORME
	>36 60x120 - 60x60 - 30x60 Ivory/Taupe/Silver/Grey/Black	-

Piastrelle pressate a secco - Conforme alla norma EN 14411 e ISO 13006 appendice G gruppo B1-a con E ≤0,5%

Dry pressed tiles - Compliant with standards EN 14411 and ISO 13006 annex G group B1-a with E ≤0,5% / Carreau pressé à sec - Conforme à la norme EN 14411 et ISO 13006 annexe g groupe B1-a avec E ≤0,5% / Trocken gepresste Fliesen - Erfüllen die Anforderungen der Norm en 14411 und ISO 13006 Anhang g Gruppe B1-a mit E ≤0,5% / Baldosas prensadas en seco - Conforme a las normas en 14411 e iso 13006, anexo g grupo B1-a con E ≤0,5%

336/337

VALORI VALUES / VALEURS WERTE / VALORES	VALORI VALUES / VALEURS WERTE / VALORES	VALORI VALUES / VALEURS WERTE / VALORES	VALORI VALUES / VALEURS WERTE / VALORES
EVOKE	GRANIGLIATI - LINEA TECNICA	IKON	INTERNO4
 <b>CONFORME</b> COMPLIANT / CONFORME ANFORDERUNGEN ERFÜLLT / CONFORME	-	<b>CONFORME</b> COMPLIANT / CONFORME ANFORDERUNGEN ERFÜLLT / CONFORME	<b>CONFORME</b> COMPLIANT / CONFORME ANFORDERUNGEN ERFÜLLT / CONFORME
 -	<b>CONFORME</b> COMPLIANT / CONFORME ANFORDERUNGEN ERFÜLLT / CONFORME	-	-
 ≤0,1%	≤0,1%	≤0,1%	≤0,1%
 9 mm    20 mm R≥40 N/mm <sup>2</sup> S≥1500 N	9 mm    20 mm R≥40 N/mm <sup>2</sup> S≥1500 N	9 mm    9 mm    20 mm R≥40 N/mm <sup>2</sup> R≥40 N/mm <sup>2</sup> R≥45 N/mm <sup>2</sup> S≥1000 N    S≥1500 N    S≥10000 N	6 mm    9 mm    20 mm    6 mm    9 mm R≥40 N/mm <sup>2</sup> S≥1000 N    S≥1500 N    R≥40 N/mm <sup>2</sup> R≥40 N/mm <sup>2</sup>
 ≤150 mm <sup>3</sup>	≤150 mm <sup>3</sup>	≤150 mm <sup>3</sup>	≤150 mm <sup>3</sup>
 -	-	-	<b>TEST DISPONIBILE</b> TEST AVAILABLE / TEST DISPONIBLE / TEST VERFÜGBAR / PRUEBA DISPONIBLE
 <b>CONFORME</b> COMPLIANT / CONFORME ANFORDERUNGEN ERFÜLLT / CONFORME	<b>CONFORME</b> COMPLIANT / CONFORME ANFORDERUNGEN ERFÜLLT / CONFORME	<b>CONFORME</b> COMPLIANT / CONFORME ANFORDERUNGEN ERFÜLLT / CONFORME	<b>CONFORME</b> COMPLIANT / CONFORME ANFORDERUNGEN ERFÜLLT / CONFORME
 <b>CONFORME</b> COMPLIANT / CONFORME ANFORDERUNGEN ERFÜLLT / CONFORME	<b>CONFORME</b> COMPLIANT / CONFORME ANFORDERUNGEN ERFÜLLT / CONFORME	<b>CONFORME</b> COMPLIANT / CONFORME ANFORDERUNGEN ERFÜLLT / CONFORME	<b>CONFORME</b> COMPLIANT / CONFORME ANFORDERUNGEN ERFÜLLT / CONFORME
 <b>CONFORME</b> COMPLIANT / CONFORME ANFORDERUNGEN ERFÜLLT / CONFORME	<b>CONFORME</b> COMPLIANT / CONFORME ANFORDERUNGEN ERFÜLLT / CONFORME	<b>CONFORME</b> COMPLIANT / CONFORME ANFORDERUNGEN ERFÜLLT / CONFORME	<b>CONFORME</b> COMPLIANT / CONFORME ANFORDERUNGEN ERFÜLLT / CONFORME
 <b>CONFORME</b> COMPLIANT / CONFORME ANFORDERUNGEN ERFÜLLT / CONFORME	<b>CONFORME</b> COMPLIANT / CONFORME ANFORDERUNGEN ERFÜLLT / CONFORME	<b>CONFORME</b> COMPLIANT / CONFORME ANFORDERUNGEN ERFÜLLT / CONFORME	<b>CONFORME</b> COMPLIANT / CONFORME ANFORDERUNGEN ERFÜLLT / CONFORME
 <b>R9</b> 30x120 - 20x120 - 15x120 <b>R11</b> 20x120 - 30x120 K2	<b>R9</b> 30x30 Not RT <b>R12</b> 30x30 Not RT	<b>R9</b> 120x278 - 120x120 - 60x120 - 30x120 - 90x90 - 60x60 <b>R10</b> 120x120 - 60x120 - 30x120 - 60x60 30x60 - 9,7x60 <b>R11</b> 30x60 - 90x90 K2 - 60x60 K2	<b>Lappato</b> 120x278 - 80x160 - 120x120 60x120 - 30x120 - 80x80 - 60x60 <b>R9</b> 60x120 - 80x80
<b>A+B</b> Natural R9 / <b>A+B+C</b> Structured R11	<b>A</b> Natural R9 / <b>A+B+C</b> R12	<b>A</b> Natural R9 / <b>A+B</b> Grip R10 / <b>A+B+C</b> Grip R11	- Lappato / <b>A</b> Natural R9
 <b>CONFORME</b> COMPLIANT / CONFORME ANFORDERUNGEN ERFÜLLT / CONFORME	<b>CONFORME</b> COMPLIANT / CONFORME ANFORDERUNGEN ERFÜLLT / CONFORME	<b>CONFORME</b> COMPLIANT / CONFORME ANFORDERUNGEN ERFÜLLT / CONFORME	<b>CONFORME</b> COMPLIANT / CONFORME ANFORDERUNGEN ERFÜLLT / CONFORME
 <b>CONFORME</b> COMPLIANT / CONFORME ANFORDERUNGEN ERFÜLLT / CONFORME	<b>CONFORME</b> COMPLIANT / CONFORME ANFORDERUNGEN ERFÜLLT / CONFORME	<b>CONFORME</b> COMPLIANT / CONFORME ANFORDERUNGEN ERFÜLLT / CONFORME	<b>CONFORME</b> COMPLIANT / CONFORME ANFORDERUNGEN ERFÜLLT / CONFORME
 -	-	>36 120x120 (no Silver/Beige) - 60x120 - 30x120 - 60x60 - 30x60 - 9,7x60 Grey/Silver/White/Sky/Beige	-

## INFORMAZIONI TECNICHE

TECHNICAL FEATURES / INFORMATIONS TECHNIQUES / TECHNISCHE INFORMATIONEN / INFORMACIÓN TÉCNICA

DESCRIZIONE DESCRIPTION / DESCRIPTION BESCHREIBUNG / DESCRIPCIÓN	VALORI VALUES / VALEURS WERTE / VALORES	VALORI VALUES / VALEURS WERTE / VALORES	VALORI VALUES / VALEURS WERTE / VALORES	VALORI VALUES / VALEURS WERTE / VALORES
	K-COLOR	LIMES		
<b>DIMENSIONI Rettificato</b> SIZES RECTIFIED / FORMAT RECTIFIÉ / ABMESSUNGEN NACH DEM SCHLEIFEN / TAMAÑO RECTIFICADO	–	<b>CONFORME</b> COMPLIANT / CONFORME ANFORDERUNGEN ERFÜLLT / CONFORME		
<b>DIMENSIONI Non Rettificato</b> SIZES NOT RECTIFIED / FORMAT NON RECTIFIÉ / ABMESSUNGEN VOR DEM SCHLEIFEN / TAMAÑO NO RECTIFICADO	<b>CONFORME</b> COMPLIANT / CONFORME ANFORDERUNGEN ERFÜLLT / CONFORME	<b>CONFORME</b> COMPLIANT / CONFORME ANFORDERUNGEN ERFÜLLT / CONFORME 22,5x45,3 - 22,5x22,5		–
<b>ASSORBIMENTO ACQUA</b> WATER ABSORPTION / ABSORPTION D'EAU / WASSERAUFNAHME / ABSORCIÓN DE AGUA	≤0,1%	≤0,1%		
<b>RESISTENZA A ROTTURA</b> BREAKING STRENGTH / RESISTANCE À LA RUPTURE / BRUCHFESTIGKEIT / RESISTENCIA A LA ROTURA	<b>7,3 mm</b> <b>R≥40 N/mm²</b> <b>S≥1000 N</b>	<b>9 mm</b> <b>R≥40 N/mm²</b> <b>S≥1500 N</b>	<b>20 mm</b> <b>R≥45 N/mm²</b> <b>S≥10000 N</b>	
<b>RESISTENZA ABRASIONE PROFONDA (UGL - Matt)</b> DEEP ABRASION RESISTANCE (UGL - Matt) / RESISTANCE À L'ABRASION PROFONDE (UGL - Matt) / TIEFENVERSCHLEISSBESTÄNDIGKEIT (UGL - Matt) / RESISTENCIA A LA ABRASIÓN PROFUNDA (UGL - Matt)	–	≤150 mm³		
<b>RESIST. ABRASIONE SUPERFICIALE (GL - Lappato / Silky)</b> SURFACE ABRASION RESISTANCE (GL - Lapped / Silky) / RESIST. À L'ABRASION SUPERFICIELLE (GL - Rodé / Silky) / WIDERSTÄNDIGKEIT GEGEN OBERFLÄCHENVERSCHLEISS (GL - geläppt / silky) / RESIST. ABRASIÓN SUPERFICIAL (GL - esmaltado / Silky)	<b>TEST DISPONIBILE</b> TEST AVAILABLE / TEST DISPONIBLE / TEST VERFÜGBAR / PRUEBA DISPONIBLE	–		
<b>RESISTENZA SHOCK TERMICI</b> THERMAL SHOCK RESISTANCE / RESISTANCE AUX ÉCARTS DE TEMPÉRATURE / WIDERSTANDSFÄHIGKEIT GEGEN TEMPERATURSCHWANKUNGEN / RESISTENCIA A LOS CAMBIOS DE TEMPERATURA	<b>CONFORME</b> COMPLIANT / CONFORME ANFORDERUNGEN ERFÜLLT / CONFORME	<b>CONFORME</b> COMPLIANT / CONFORME ANFORDERUNGEN ERFÜLLT / CONFORME		
<b>RESISTENZA AL GELO</b> FROST RESISTANCE / RESISTANCE AU GEL / FROSTWIDERSTANDSFÄHIGKEIT / RESISTENCIA AL HIELO	<b>CONFORME</b> COMPLIANT / CONFORME ANFORDERUNGEN ERFÜLLT / CONFORME	<b>CONFORME</b> COMPLIANT / CONFORME ANFORDERUNGEN ERFÜLLT / CONFORME		
<b>RESISTENZA CHIMICA</b> CHEMICAL RESISTANCE / RESISTANCE CHIMIQUE CHEMISCHE BESTÄNDIGKEIT / RESISTENCIA QUÍMICA	<b>CONFORME</b> COMPLIANT / CONFORME ANFORDERUNGEN ERFÜLLT / CONFORME	<b>CONFORME</b> COMPLIANT / CONFORME ANFORDERUNGEN ERFÜLLT / CONFORME		
<b>RESISTENZA ALLE MACCHIE</b> STAIN RESISTANCE / RESISTANCE AUX TACHES / FLECKENFESTIGKEIT / RESISTENCIA A LAS MANCHAS	<b>CONFORME</b> COMPLIANT / CONFORME ANFORDERUNGEN ERFÜLLT / CONFORME	<b>CONFORME</b> COMPLIANT / CONFORME ANFORDERUNGEN ERFÜLLT / CONFORME		
<b>CLASSIFICAZIONE ANTISDRUCCIOLO</b> ASSESSMENT OF SLIP RESISTANCE / CLASSIFICATION ANTIGLISSE RUTSCHFESTIGKEITSKLASSE / CLASIFICACIÓN ANTIDESLIZANTE	<b>– Natural 20x20 Not RT</b> <b>R10 20x20 Not RT</b>	<b>R10</b> 60x120 - 60x60 - 30x60 <b>R11</b> 30x60 - 22,5x45,3 - 22,5x22,5 - 60x90 K2		
	<b>– Natural</b> <b>A Grip R10</b>	<b>A+B Natural R10</b> <b>A+B+C Structured R11</b>		
	<b>CONFORME (NO NATURAL)</b> COMPLIANT / CONFORME ANFORDERUNGEN ERFÜLLT / CONFORME	<b>CONFORME (NO NATURAL)</b> COMPLIANT / CONFORME ANFORDERUNGEN ERFÜLLT / CONFORME		
	<b>CONFORME (NO NATURAL)</b> COMPLIANT / CONFORME ANFORDERUNGEN ERFÜLLT / CONFORME	<b>CONFORME (NO NATURAL)</b> COMPLIANT / CONFORME ANFORDERUNGEN ERFÜLLT / CONFORME		
	–	–		

Piastrelle pressate a secco - Conforme alla norma EN 14411 e ISO 13006 appendice G gruppo B1-a con E ≤0,5%











Dry pressed tiles - Compliant with standards EN 14411 and ISO 13006 annex G group B1-a with E ≤0,5% / Carreau pressé à sec - Conforme à la norme EN 14411 et ISO 13006 annexe G groupe B1-a avec E ≤0,5% / Trocken gepresste Fliesen - Erfüllen die Anforderungen der Norm en 14411 und ISO 13006 Anhang g Gruppe B1-a mit E ≤0,5% / Baldosas prensadas en seco - Conforme a las normas en 14411 e iso 13006, anexo g grupo B1-a con E ≤0,5%

338/339

VALORI VALUES / VALEURS WERTE / VALORES	VALORI VALUES / VALEURS WERTE / VALORES	VALORI VALUES / VALEURS WERTE / VALORES	VALORI VALUES / VALEURS WERTE / VALORES	VALORI VALUES / VALEURS WERTE / VALORES
MIDLAKE	MOOV	NOORD	PERCORSI EXTRA	
<b>CONFORME</b> COMPLIANT / CONFORME ANFORDERUNGEN ERFÜLLT / CONFORME 60x90 K2	<b>CONFORME</b> COMPLIANT / CONFORME ANFORDERUNGEN ERFÜLLT / CONFORME	<b>CONFORME</b> COMPLIANT / CONFORME ANFORDERUNGEN ERFÜLLT / CONFORME	<b>CONFORME</b> COMPLIANT / CONFORME ANFORDERUNGEN ERFÜLLT / CONFORME	
<b>CONFORME</b> COMPLIANT / CONFORME ANFORDERUNGEN ERFÜLLT / CONFORME	<b>CONFORME</b> COMPLIANT / CONFORME ANFORDERUNGEN ERFÜLLT / CONFORME 45x45 - 7,5x30	–	–	
≤0,1%	≤0,1% / K3 (≤0,5%)	≤0,1%	≤0,1% / K3 (≤0,5%)	
<b>9 mm</b> <b>R≥40 N/mm²</b> <b>S≥1500 N</b>	<b>20 mm</b> <b>R≥45 N/mm²</b> <b>S≥10000 N</b>	<b>6 mm</b> <b>9 mm</b> <b>20 mm</b> <b>30 mm</b> <b>R≥40 N/mm²</b> <b>R≥40 N/mm²</b> <b>R≥45 N/mm²</b> <b>R≥45 N/mm²</b> <b>S≥1000 N</b> <b>S≥1500 N</b> <b>S≥10000 N</b> <b>S≥25000 N</b>	<b>9 mm</b> <b>20 mm</b> <b>R≥40 N/mm²</b> <b>R≥45 N/mm²</b> <b>S≥1500 N</b> <b>S≥10000 N</b>	<b>9 mm</b> <b>20 mm</b> <b>30 mm</b> <b>R≥40 N/mm²</b> <b>R≥45 N/mm²</b> <b>R≥45 N/mm²</b> <b>S≥1500 N</b> <b>S≥10000 N</b> <b>S≥25000 N</b>
≤150 mm³	≤150 mm³	≤150 mm³	≤150 mm³	
–	–	–	–	
<b>CONFORME</b> COMPLIANT / CONFORME ANFORDERUNGEN ERFÜLLT / CONFORME	<b>CONFORME</b> COMPLIANT / CONFORME ANFORDERUNGEN ERFÜLLT / CONFORME	<b>CONFORME</b> COMPLIANT / CONFORME ANFORDERUNGEN ERFÜLLT / CONFORME	<b>CONFORME</b> COMPLIANT / CONFORME ANFORDERUNGEN ERFÜLLT / CONFORME	
<b>CONFORME</b> COMPLIANT / CONFORME ANFORDERUNGEN ERFÜLLT / CONFORME	<b>CONFORME</b> COMPLIANT / CONFORME ANFORDERUNGEN ERFÜLLT / CONFORME	<b>CONFORME</b> COMPLIANT / CONFORME ANFORDERUNGEN ERFÜLLT / CONFORME	<b>CONFORME</b> COMPLIANT / CONFORME ANFORDERUNGEN ERFÜLLT / CONFORME	
<b>CONFORME</b> COMPLIANT / CONFORME ANFORDERUNGEN ERFÜLLT / CONFORME	<b>CONFORME</b> COMPLIANT / CONFORME ANFORDERUNGEN ERFÜLLT / CONFORME	<b>CONFORME</b> COMPLIANT / CONFORME ANFORDERUNGEN ERFÜLLT / CONFORME	<b>CONFORME</b> COMPLIANT / CONFORME ANFORDERUNGEN ERFÜLLT / CONFORME	
<b>CONFORME</b> COMPLIANT / CONFORME ANFORDERUNGEN ERFÜLLT / CONFORME	<b>CONFORME</b> COMPLIANT / CONFORME ANFORDERUNGEN ERFÜLLT / CONFORME	<b>CONFORME</b> COMPLIANT / CONFORME ANFORDERUNGEN ERFÜLLT / CONFORME	<b>CONFORME</b> COMPLIANT / CONFORME ANFORDERUNGEN ERFÜLLT / CONFORME	
<b>R11</b> 22,5x45,3 Not RT - 22,5x22,5 Not RT - 60x90 K2 - 22,5x45,4 K2 Not RT - 22,5x22,5 K2 Not RT	<b>R9</b> 120x278 - 120x240 - 120x120 - 60x120 30x120 - 20x120 - 75x75 - 60x60 - 30x60 - 14,7x60 - 9,7x60- 6,4x60 - 3,1x60 - 45x45 Not RT / <b>R10</b> 120x120 - 60x120 - 60x60 - 30x60 - 7,5x30 Not RT / <b>R11</b> 60x120 - 60x60 - 30x60 - 120x120 K2 - 90x90 K2 - 60x60 K2 - 60x60 K3	<b>R10</b> 120x120 - 60x120 - 30x120 - 80x80 - 60x60 - 30x60 - 9,7x60 <b>R11</b> 60x120 - 60x60 - 30x60 - 120x240 K2 - 120x120 K2 - 60x120 K2 - 30x120 K2 - 45x90 K2 - 80x80 K2 - 60x60 K2 - 30x60 K2	<b>R9</b> 60x120 - 60x60 - 30x60 <b>R10</b> 60x120 - 60x60 - 30x60 <b>R11</b> 60x120 - 60x60 - 30x60 - 120x240 K2 - 120x120 K2 - 60x120 K2 - 30x120 K2 - 45x90 K2 - 80x80 K2 - 60x60 K2 - 60x60 K3	
<b>A+B+C Structured R11</b>	<b>A</b> Natural R9 <b>A+B</b> Structured R10 - Grip R10 <b>A+B+C</b> Grip R11	<b>A+B</b> Natural R10 <b>A+B+C</b> Grip R11	<b>A</b> Natural R9 / <b>A+B</b> Structured R10 / <b>A+B+C</b> Structured R11 (PIETRA DI BARGE <b>A+B</b> , altri colori <b>A+B+C</b> )	
<b>CONFORME</b> COMPLIANT / CONFORME ANFORDERUNGEN ERFÜLLT / CONFORME	<b>CONFORME</b> COMPLIANT / CONFORME ANFORDERUNGEN ERFÜLLT / CONFORME	<b>CONFORME</b> COMPLIANT / CONFORME ANFORDERUNGEN ERFÜLLT / CONFORME	<b>CONFORME</b> COMPLIANT / CONFORME ANFORDERUNGEN ERFÜLLT / CONFORME	
<b>CONFORME</b> COMPLIANT / CONFORME ANFORDERUNGEN ERFÜLLT / CONFORME	<b>CONFORME</b> COMPLIANT / CONFORME ANFORDERUNGEN ERFÜLLT / CONFORME	<b>CONFORME</b> COMPLIANT / CONFORME ANFORDERUNGEN ERFÜLLT / CONFORME	<b>CONFORME</b> COMPLIANT / CONFORME ANFORDERUNGEN ERFÜLLT / CONFORME	
–	>36 120x120 - 60x120 - 60x60 - 30x60 Grey/Anthracite/Moka/Ivory	>36 120x120 - 60x120 - 30x120 - 80x80 60x60 - 30x60 - 9,7x60 Anthracite/Grey/Taupe/Gold/White	>36 60x120 - 60x60 - 30x60 Pietra di Vals/Pietra di Barge/ Pietra di Faedis	

## INFORMAZIONI TECNICHE













TECHNICAL FEATURES / INFORMATIONS TECHNIQUES / TECHNISCHE INFORMATIONEN / INFORMACIÓN TÉCNICA









DESCRIZIONE DESCRIPTION / DESCRIPTION BESCHREIBUNG / DESCRIPCIÓN	VALORI VALUES / VALEURS WERTE / VALORES		VALORI VALUES / VALEURS WERTE / VALORES		
	PERCORSI QUARTZ		PERCORSI SMART		
 <b>DIMENSIONI RETTIFICATO</b> SIZES RECTIFIED / FORMAT RECTIFIÉ / ABMESSUNGEN NACH DEM SCHLEIFEN / TAMAÑO RECTIFICADO	<b>CONFORME</b> COMPLIANT / CONFORME ANFORDERUNGEN ERFÜLLT / CONFORME		<b>CONFORME</b> COMPLIANT / CONFORME ANFORDERUNGEN ERFÜLLT / CONFORME		
 <b>DIMENSIONI NON RETTIFICATO</b> SIZES NOT RECTIFIED / FORMAT NON RECTIFIÉ / ABMESSUNGEN VOR DEM SCHLEIFEN / TAMAÑO NO RECTIFICADO	-		<b>CONFORME</b> COMPLIANT / CONFORME ANFORDERUNGEN ERFÜLLT / CONFORME 15x30		
 <b>ASSORBIMENTO ACQUA</b> WATER ABSORPTION / ABSORPTION D'EAU / WASSERAUFNAHME / ABSORCIÓN DE AGUA	≤0,1%		≤0,1% / K3 (≤0,5%)		
 <b>RESISTENZA A ROTTURA</b> BREAKING STRENGHT / RESISTANCE À LA RUPTURE / BRUCHFESTIGKEIT / RESISTENCIA A LA ROTURA	<b>9 mm</b>	<b>20 mm</b>	<b>9 mm</b>	<b>20 mm</b>	<b>30 mm</b>
	<b>R≥40 N/mm<sup>2</sup></b> <b>S≥15000 N</b>	<b>R≥45 N/mm<sup>2</sup></b> <b>S≥10000 N</b>	<b>R≥40 N/mm<sup>2</sup></b> <b>S≥15000 N</b>	<b>R≥45 N/mm<sup>2</sup></b> <b>S≥10000 N</b>	<b>R≥45 N/mm<sup>2</sup></b> <b>S≥25000 N</b>
 <b>RESISTENZA ABRASIONE PROFONDA (UGL - Matt)</b> DEEP ABRASION RESISTANCE (UGL - Matt) / RESISTANCE À L'ABRASION PROFONDE (UGL - Matt) / TIEFENVERSCHLEISSBESTÄNDIGKEIT (UGL - Matt) / RESISTENCIA A LA ABRASIÓN PROFUNDA (UGL - Matt)	≤150 mm <sup>3</sup>		≤150 mm <sup>3</sup>		
 <b>RESIST. ABRASIONE SUPERFICIALE (GL - Lappato / Silky)</b> SURFACE ABRASION RESISTANCE (GL - Lappato / Silky) / RESIST. À L'ABRASION SUPERFICIELLE (GL - Rodé / Silky) / WIDERSTÄNDIGKEIT GEGEN OBERFLÄCHENVERSCHLEISS (GL - geläppt / silky) / RESIST. ABRASIÓN SUPERFICIAL (GL: esmaltado / Silky)	-		-		
 <b>RESISTENZA SHOCK TERMICI</b> THERMAL SHOCK RESISTANCE / RESISTANCE AUX ÉCARTS DE TEMPÉRATURE / WIDERSTANDSFÄHIGKEIT GEGEN TEMPERATURSCHWANKUNGEN / RESISTENCIA A LOS CAMBIOS DE TEMPERATURA	<b>CONFORME</b> COMPLIANT / CONFORME ANFORDERUNGEN ERFÜLLT / CONFORME		<b>CONFORME</b> COMPLIANT / CONFORME ANFORDERUNGEN ERFÜLLT / CONFORME		
 <b>RESISTENZA AL GELO</b> FROST RESISTANCE / RESISTANCE AU GEL / FROSTWIDERSTANDSFÄHIGKEIT / RESISTENCIA AL HIELO	<b>CONFORME</b> COMPLIANT / CONFORME ANFORDERUNGEN ERFÜLLT / CONFORME		<b>CONFORME</b> COMPLIANT / CONFORME ANFORDERUNGEN ERFÜLLT / CONFORME		
 <b>RESISTENZA CHIMICA</b> CHEMICAL RESISTANCE / RESISTANCE CHIMIQUE CHEMISCHE BESTÄNDIGKEIT / RESISTENCIA QUÍMICA	<b>CONFORME</b> COMPLIANT / CONFORME ANFORDERUNGEN ERFÜLLT / CONFORME		<b>CONFORME</b> COMPLIANT / CONFORME ANFORDERUNGEN ERFÜLLT / CONFORME		
 <b>RESISTENZA ALLE MACCHIE</b> STAIN RESISTANCE / RESISTANCE AUX TACHES / FLECKENFESTIGKEIT / RESISTENCIA A LAS MANCHAS	<b>CONFORME</b> COMPLIANT / CONFORME ANFORDERUNGEN ERFÜLLT / CONFORME		<b>CONFORME</b> COMPLIANT / CONFORME ANFORDERUNGEN ERFÜLLT / CONFORME		
 <b>CLASSIFICAZIONE ANTISDRUCCIOLO</b> ASSESSMENT OF SLIP RESISTANCE / CLASSIFICATION ANTIGLISSE RUTSCHFESTIGKEITSKLASSE/CLASIFICACIÓN ANTIDESLIZANTE	<b>R9</b> 60x60 - 30x60 <b>R11</b> 60x60 - 30x60 - 60x60 K2		<b>R9</b> 60x60 - 30x60 <b>R11</b> 60x60 - 30x60 - 15x30 Not RT - 120x240 K2 - 30x240 K2 - 120x120 K2 - 45x90 K2 - 60x60 K2 - 60x60 K3		
	<b>A</b> Natural R9 / <b>A+B+C</b> Structured R11		<b>A</b> Natural R9 / <b>A+B+C</b> Structured R11		
	<b>CONFORME</b> COMPLIANT / CONFORME ANFORDERUNGEN ERFÜLLT / CONFORME		<b>CONFORME</b> COMPLIANT / CONFORME ANFORDERUNGEN ERFÜLLT / CONFORME		
	<b>CONFORME</b> COMPLIANT / CONFORME ANFORDERUNGEN ERFÜLLT / CONFORME		<b>CONFORME</b> COMPLIANT / CONFORME ANFORDERUNGEN ERFÜLLT / CONFORME		
	-		-		

Piastrelle pressate a secco - Conforme alla norma EN 14411 e ISO 13006 appendice G gruppo B1-a con E ≤0,5%

Dry pressed tiles - Compliant with standards EN 14411 and ISO 13006 annex G group B1-a with E ≤0,5% / Carreau pressé à sec - Conforme à la norme EN 14411 et ISO 13006 annexe g groupe B1-a avec E ≤0,5% / Trocken gepresste Fliesen - Erfüllen die Anforderungen der Norm en 14411 und ISO 13006 Anhang g Gruppe B1-a mit E ≤0,5% / Baldosas prensadas en seco - Conforme a las normas en 14411 e iso 13006, anexo g grupo B1-a con E ≤0,5 %









**340/341**











VALORI VALUES / VALEURS WERTE / VALORES	VALORI VALUES / VALEURS WERTE / VALORES	VALORI VALUES / VALEURS WERTE / VALORES	VALORI VALUES / VALEURS WERTE / VALORES	
			SIGHT	SOUL
 <b>CONFORME</b> COMPLIANT / CONFORME ANFORDERUNGEN ERFÜLLT / CONFORME	<b>CONFORME</b> COMPLIANT / CONFORME ANFORDERUNGEN ERFÜLLT / CONFORME	<b>CONFORME</b> COMPLIANT / CONFORME ANFORDERUNGEN ERFÜLLT / CONFORME	<b>CONFORME</b> COMPLIANT / CONFORME ANFORDERUNGEN ERFÜLLT / CONFORME	
 -	-	-	-	
 ≤0,1%	≤0,1%	≤0,1%	≤0,1%	
 20 mm	20 mm	9 mm	9 mm	20 mm
 <b>R≥45 N/mm<sup>2</sup></b> <b>S≥10000 N</b>	<b>R≥45 N/mm<sup>2</sup></b> <b>S≥10000 N</b>	<b>R≥40 N/mm<sup>2</sup></b> <b>S≥1500 N</b>	<b>R≥40 N/mm<sup>2</sup></b> <b>S≥1500 N</b>	<b>R≥45 N/mm<sup>2</sup></b> <b>S≥10000 N</b>
 ≤150 mm <sup>3</sup>	≤150 mm <sup>3</sup>	≤150 mm <sup>3</sup>	≤150 mm <sup>3</sup>	
 -	-	-	-	
 <b>CONFORME</b> COMPLIANT / CONFORME ANFORDERUNGEN ERFÜLLT / CONFORME	<b>CONFORME</b> COMPLIANT / CONFORME ANFORDERUNGEN ERFÜLLT / CONFORME	<b>CONFORME</b> COMPLIANT / CONFORME ANFORDERUNGEN ERFÜLLT / CONFORME	<b>CONFORME</b> COMPLIANT / CONFORME ANFORDERUNGEN ERFÜLLT / CONFORME	
 <b>CONFORME</b> COMPLIANT / CONFORME ANFORDERUNGEN ERFÜLLT / CONFORME	<b>CONFORME</b> COMPLIANT / CONFORME ANFORDERUNGEN ERFÜLLT / CONFORME	<b>CONFORME</b> COMPLIANT / CONFORME ANFORDERUNGEN ERFÜLLT / CONFORME	<b>CONFORME</b> COMPLIANT / CONFORME ANFORDERUNGEN ERFÜLLT / CONFORME	
 <b>CONFORME</b> COMPLIANT / CONFORME ANFORDERUNGEN ERFÜLLT / CONFORME	<b>CONFORME</b> COMPLIANT / CONFORME ANFORDERUNGEN ERFÜLLT / CONFORME	<b>CONFORME</b> COMPLIANT / CONFORME ANFORDERUNGEN ERFÜLLT / CONFORME	<b>CONFORME</b> COMPLIANT / CONFORME ANFORDERUNGEN ERFÜLLT / CONFORME	
 <b>CONFORME</b> COMPLIANT / CONFORME ANFORDERUNGEN ERFÜLLT / CONFORME	<b>CONFORME</b> COMPLIANT / CONFORME ANFORDERUNGEN ERFÜLLT / CONFORME	<b>CONFORME</b> COMPLIANT / CONFORME ANFORDERUNGEN ERFÜLLT / CONFORME	<b>CONFORME</b> COMPLIANT / CONFORME ANFORDERUNGEN ERFÜLLT / CONFORME	
	R11 60x60 K2	R11 30x120 K2	R10 60x120 - 60x60 - 30x60	R10 120x120 - 60x120 - 30x120 - 60x60 - 30x60 - 9,7x60 R11 60x120 K2 - 60x60 K2
	<b>A+B+C</b> Structured R11	<b>A+B+C</b> Structured R11	<b>A+B</b> Grip R10	<b>A+B</b> Natural R10 <b>A+B+C</b> Structured R11
 <b>CONFORME</b> COMPLIANT / CONFORME ANFORDERUNGEN ERFÜLLT / CONFORME	<b>CONFORME</b> COMPLIANT / CONFORME ANFORDERUNGEN ERFÜLLT / CONFORME	<b>CONFORME</b> COMPLIANT / CONFORME ANFORDERUNGEN ERFÜLLT / CONFORME	<b>CONFORME</b> COMPLIANT / CONFORME ANFORDERUNGEN ERFÜLLT / CONFORME	
 <b>CONFORME</b> COMPLIANT / CONFORME ANFORDERUNGEN ERFÜLLT / CONFORME	<b>CONFORME</b> COMPLIANT / CONFORME ANFORDERUNGEN ERFÜLLT / CONFORME	<b>CONFORME</b> COMPLIANT / CONFORME ANFORDERUNGEN ERFÜLLT / CONFORME	<b>CONFORME</b> COMPLIANT / CONFORME ANFORDERUNGEN ERFÜLLT / CONFORME	
	-	-	> <b>36</b> 60x120 - 60x60 - 30x60 Quartz/Golden/Smoke/Cabernet	> <b>36</b> 120x120 - 60x120 - 30x120 - 60x60 - 30x60 - 9,7x60

DESCRIZIONE DESCRIPTION / DESCRIPTION BESCHREIBUNG / DESCRIPCIÓN	NORME REGULATION / NORME / NORM / NORMA	REQUISITI PRESCRITTI REQUIRED VALUES / EXIGENCES RÉGLEMENTAIRES / VORGE- SCHRIEBENE ANFORDERUNGEN / REQUISITOS ESTABLECIDOS
	EN 14411 - ISO 13006	
	UNI EN ISO 10545-2	lunghezza-larghezza $\pm 0,3\%$ ( $\pm 1,0$ mm max) <i>length-width / longueur-largeur / Länge-Breite / longitud-ancho</i> spessore $\pm 5,0\%$ ( $\pm 0,5$ mm max) <i>thickness / épaisseur / Stärke / espesor</i> ortogonalità $\pm 0,3\%$ ( $\pm 1,5$ mm max) <i>rectangularity / orthogonalité / Rechtwinkligkeit / ortogonalidad</i> rettilinearità $\pm 0,3\%$ ( $\pm 0,8$ mm max) <i>straightness / rectilignité / Geradlinigkeit / rectilineidad</i> planarità $\pm 0,4\%$ ( $\pm 1,8$ mm max) <i>surface flatness / planéité / Ebenflächigkeit / planaridad</i> qualità superficie $\geq 95\%$ <i>surface quality / qualités surface / Oberflächenbeschaffenheit / calidades superficie</i>
		lunghezza-larghezza $\pm 0,6\%$ ( $\pm 2,0$ mm max) <i>length-width / longueur-largeur / Länge-Breite / longitud-ancho</i> spessore $\pm 5,0\%$ ( $\pm 0,5$ mm max) <i>thickness / épaisseur / Stärke / espesor</i> ortogonalità $\pm 0,5\%$ ( $\pm 2,0$ mm max) <i>rectangularity / orthogonalité / Rechtwinkligkeit / ortogonalidad</i> rettilinearità $\pm 0,5\%$ ( $\pm 1,5$ mm max) <i>straightness / rectilignité / Geradlinigkeit / rectilineidad</i> planarità $\pm 0,5\%$ ( $\pm 2,0$ mm max) <i>surface flatness / planéité / Ebenflächigkeit / planaridad</i> qualità superficie $\geq 95\%$ <i>surface quality / qualités surface / Oberflächenbeschaffenheit / calidades superficie</i>
	UNI EN ISO 10545-3	$\leq 0,5\%$
	UNI EN ISO 10545-4	$R \geq 35$ N/mm <sup>2</sup> $S \geq 700$ N ( $< 7,5$ mm) $S \geq 1300$ N ( $\geq 7,5$ mm)
	UNI EN ISO 10545-6	$\leq 175$ mm <sup>3</sup>
	UNI EN ISO 10545-6	dichiarare un valore / declare a value / déclarer une valeur / einen Wert angeben / declarar un valor
	UNI EN ISO 10545-9	resistenza / resistant / résistance / Widerständigkeit / resistencia
	UNI EN ISO 10545-12	resistenza / resistant / résistance / Widerständigkeit / resistencia
	UNI EN ISO 10545-13	resistenza / resistant / résistance / Widerständigkeit / resistencia
	UNI EN ISO 10545-14	pulibile / cleanable / nettoyable / kann gereinigt werden / lavable
	DIN 51130	R
	DIN 51097	A+B+C
	B.C.R.A. (COF)	$> 0,40$ bagnato / wet
	ANSI A137.1 2012 (DCOF)	$> 0,42$ bagnato / wet
	BS 7976-2:2002 (UK) (Pendulum Test Value)	0-24 scivoloso / slippery / glissant / Rutschig / resbaladizo 25-35 scivolosità moderata / moderately slippery / glissance modérée / mäßige Rutschgefahr / Deslizamiento moderado $> 36$ basso rischio scivolamento / low slipping risk / risque de glissement faible / geringe Rutschgefahr / bajo riesgo de deslizamiento

Piastrelle pressate a secco - Conforme alla norma EN 14411 e ISO 13006 appendice G gruppo B1-a con E  $\leq 0,5\%$

Dry pressed tiles - Compliant with standards EN 14411 and ISO 13006 annex G group B1-a with E  $\leq 0,5\%$  / Carreau pressé à sec - Conforme à la norme EN 14411 et ISO 13006 annexe G groupe B1-a avec E  $\leq 0,5\%$  / Trocken gepresste Fliesen - Erfüllen die Anforderungen der Norm en 14411 und ISO 13006 Anhang G Gruppe B1-a mit E  $\leq 0,5\%$  / Baldosas prensadas en seco - Conforme a las normas en 14411 e iso 13006, anexo g grupo B1-a con E  $\leq 0,5\%$





VALORI VALUES / VALEURS WERTE / VALORES	VALORI VALUES / VALEURS WERTE / VALORES	VALORI VALUES / VALEURS WERTE / VALORES	VALORI VALUES / VALEURS WERTE / VALORES
CODE	DUNSTONE	EXTREME	LONDALE
	CONFORME COMPLIANT / CONFORME ANFORDERUNGEN ERFÜLLT / CONFORME	CONFORME COMPLIANT / CONFORME ANFORDERUNGEN ERFÜLLT / CONFORME	CONFORME COMPLIANT / CONFORME ANFORDERUNGEN ERFÜLLT / CONFORME
-	-	-	-
	$\leq 0,1\%$	$\leq 0,1\%$	$\leq 0,1\%$
	9 / 8,5 mm $R \geq 40$ N/mm <sup>2</sup> $S \geq 1500$ N	9 / 8,5 mm $R \geq 40$ N/mm <sup>2</sup> $S \geq 1500$ N	20 mm $R \geq 45$ N/mm <sup>2</sup> $S \geq 10000$ N
	$\leq 150$ mm <sup>3</sup>	$\leq 150$ mm <sup>3</sup>	$\leq 150$ mm <sup>3</sup>
-	-	-	-
	CONFORME COMPLIANT / CONFORME ANFORDERUNGEN ERFÜLLT / CONFORME	CONFORME COMPLIANT / CONFORME ANFORDERUNGEN ERFÜLLT / CONFORME	CONFORME COMPLIANT / CONFORME ANFORDERUNGEN ERFÜLLT / CONFORME
	CONFORME COMPLIANT / CONFORME ANFORDERUNGEN ERFÜLLT / CONFORME	CONFORME COMPLIANT / CONFORME ANFORDERUNGEN ERFÜLLT / CONFORME	CONFORME COMPLIANT / CONFORME ANFORDERUNGEN ERFÜLLT / CONFORME
	CONFORME COMPLIANT / CONFORME ANFORDERUNGEN ERFÜLLT / CONFORME	CONFORME COMPLIANT / CONFORME ANFORDERUNGEN ERFÜLLT / CONFORME	CONFORME COMPLIANT / CONFORME ANFORDERUNGEN ERFÜLLT / CONFORME
	CONFORME COMPLIANT / CONFORME ANFORDERUNGEN ERFÜLLT / CONFORME	CONFORME COMPLIANT / CONFORME ANFORDERUNGEN ERFÜLLT / CONFORME	CONFORME COMPLIANT / CONFORME ANFORDERUNGEN ERFÜLLT / CONFORME
	R9 60x120 - 60x60 - 30x60	R9 60x120 - 60x60 - 30x60	R11 45x90 K2 - 60x60 K2
	A Natural R9	A Natural R9	A+B+C Structured R11
	CONFORME COMPLIANT / CONFORME ANFORDERUNGEN ERFÜLLT / CONFORME	CONFORME COMPLIANT / CONFORME ANFORDERUNGEN ERFÜLLT / CONFORME	CONFORME COMPLIANT / CONFORME ANFORDERUNGEN ERFÜLLT / CONFORME
	CONFORME COMPLIANT / CONFORME ANFORDERUNGEN ERFÜLLT / CONFORME	CONFORME COMPLIANT / CONFORME ANFORDERUNGEN ERFÜLLT / CONFORME	CONFORME COMPLIANT / CONFORME ANFORDERUNGEN ERFÜLLT / CONFORME
-	-	-	-

DESCRIZIONE DESCRIPTION / DESCRIPTION BESCHREIBUNG / DESCRIPCIÓN	VALORI VALUES / VALEURS WERTE / VALORES	VALORI VALUES / VALEURS WERTE / VALORES
	POINT	SKYWALL
 <b>DIMENSIONI RETTIFICATO</b> SIZES RECTIFIED / FORMAT RECTIFIÉ / ABMESSUNGEN NACH DEM SCHLEIFEN / TAMAÑO RECTIFICADO	-	<b>CONFORME</b> COMPLIANT / CONFORME ANFORDERUNGEN ERFÜLLT / CONFORME
 <b>DIMENSIONI NON RETTIFICATO</b> SIZES NOT RECTIFIED / FORMAT NON RECTIFIÉ / ABMESSUNGEN VOR DEM SCHLEIFEN / TAMAÑO NO RECTIFICADO	<b>CONFORME</b> COMPLIANT / CONFORME ANFORDERUNGEN ERFÜLLT / CONFORME	-
 <b>ASSORBIMENTO ACQUA</b> WATER ABSORPTION / ABSORPTION D'EAU / WASSERAUFNAHME / ABSORCIÓN DE AGUA	≤0,1%	≤0,1%
 <b>RESISTENZA A ROTTURA</b> BREAKING STRENGHT / RESISTANCE À LA RUPTURE / BRUCHFESTIGKEIT / RESISTENCIA A LA ROTURA	<b>9 / 8,5 mm</b> <b>R≥40 N/mm²</b> <b>S≥1500 N</b>	<b>20 mm</b> <b>R≥45 N/mm²</b> <b>S≥10000 N</b>
 <b>RESISTENZA ABRASIONE PROFONDA (UGL - Matt)</b> DEEP ABRASION RESISTANCE (UGL - Matt) / RESISTANCE À L'ABRASION PROFONDE (UGL - Matt) / TIEFENVERSCHEISSBESTÄNDIGKEIT (UGL - Matt) / RESISTENCIA A LA ABRASIÓN PROFUNDA (UGL - Matt)	≤150 mm³	≤150 mm³
 <b>RESIST. ABRASIONE SUPERFICIALE (GL - Lappato / Silky)</b> SURFACE ABRASION RESISTANCE (GL - Lappato / Silky) / RESIST. À L'ABRASION SUPERFICIELLE (GL - Rodé / Silky) / WIDERSTÄNDIGKEIT GEGEN OBERFLÄCHENVERSCHEISS (GL - geläppt / silky) / RESIST. ABRASIÓN SUPERFICIAL (GL esmaltado / Silky)	-	-
 <b>RESISTENZA SHOCK TERMICI</b> THERMAL SHOCK RESISTANCE / RESISTANCE AUX ÉCARTS DE TEMPÉRATURE / WIDERSTANDSFÄHIGKEIT GEGEN TEMPERATURSCHWANKUNGEN / RESISTENCIA A LOS CAMBIOS DE TEMPERATURA	<b>CONFORME</b> COMPLIANT / CONFORME ANFORDERUNGEN ERFÜLLT / CONFORME	<b>CONFORME</b> COMPLIANT / CONFORME ANFORDERUNGEN ERFÜLLT / CONFORME
 <b>RESISTENZA AL GELO</b> FROST RESISTANCE / RESISTANCE AU GEL / FROSTWIDERSTANDSFÄHIGKEIT / RESISTENCIA AL HIELO	<b>CONFORME</b> COMPLIANT / CONFORME ANFORDERUNGEN ERFÜLLT / CONFORME	<b>CONFORME</b> COMPLIANT / CONFORME ANFORDERUNGEN ERFÜLLT / CONFORME
 <b>RESISTENZA CHIMICA</b> CHEMICAL RESISTANCE RESISTANCE / RESISTANCE CHIMIQUE CHEMISCHE BESTÄNDIGKEIT RESISTENCIA QUIMICA	<b>CONFORME</b> COMPLIANT / CONFORME ANFORDERUNGEN ERFÜLLT / CONFORME	<b>CONFORME</b> COMPLIANT / CONFORME ANFORDERUNGEN ERFÜLLT / CONFORME
 <b>RESISTENZA ALLE MACCHIE</b> STAIN RESISTANCE / RESISTANCE AUX TACHES / FLECKENFESTIGKEIT / RESISTENCIA A LAS MANCHAS	<b>CONFORME</b> COMPLIANT / CONFORME ANFORDERUNGEN ERFÜLLT / CONFORME	<b>CONFORME</b> COMPLIANT / CONFORME ANFORDERUNGEN ERFÜLLT / CONFORME
	<b>R11</b> 30x60 Not RT - 30x30 Not RT - 15x30 Not RT	<b>R11</b> 60x60 K2
	<b>A+B+C</b> Structured R11	<b>A+B+C</b> Structured R11
 <b>CLASSIFICAZIONE ANTISDRUCCIOLO</b> ASSESSMENT OF SLIP RESISTANCE / CLASSIFICATION ANTIGLISSE RUTSCHFESTIGKEITSKLASSECLASIFICACIÓN ANTIDESLIZANTE	<b>CONFORME</b> COMPLIANT / CONFORME ANFORDERUNGEN ERFÜLLT / CONFORME	<b>CONFORME</b> COMPLIANT / CONFORME ANFORDERUNGEN ERFÜLLT / CONFORME
	<b>CONFORME</b> COMPLIANT / CONFORME ANFORDERUNGEN ERFÜLLT / CONFORME	<b>CONFORME</b> COMPLIANT / CONFORME ANFORDERUNGEN ERFÜLLT / CONFORME
	-	-

Piastrelle pressate a secco - Conforme alla norma EN 14411 e ISO 13006 appendice G gruppo B1-a con E ≤0,5%

Dry pressed tiles - Compliant with standards EN 14411 and ISO 13006 annex G group B1-a with E ≤0,5% / Carreau pressé à sec - Conforme à la norme EN 14411 et ISO 13006 annexe g groupe B1-a avec E ≤0,5% / Trocken gepresste Fliesen - Erfüllen die Anforderungen der Norm en 14411 und ISO 13006 Anhang g Gruppe B1-a mit E ≤0,5% / Baldosas prensadas en seco - Conforme a las normas en 14411 e iso 13006, anexo g grupo B1-a con E ≤0,5 %

344/345

VALORI VALUES / VALEURS WERTE / VALORES	VALORI VALUES / VALEURS WERTE / VALORES
SWISSTONE	URBAN
 <b>CONFORME</b> COMPLIANT / CONFORME ANFORDERUNGEN ERFÜLLT / CONFORME	<b>CONFORME</b> COMPLIANT / CONFORME ANFORDERUNGEN ERFÜLLT / CONFORME
 -	-
 ≤0,1%	≤0,1%
 <b>9 / 8,5 mm</b> <b>R≥40 N/mm²</b> <b>S≥1500 N</b>	<b>20 mm</b> <b>R≥45 N/mm²</b> <b>S≥10000 N</b>
 ≤150 mm³	≤150 mm³
 -	-
 <b>CONFORME</b> COMPLIANT / CONFORME ANFORDERUNGEN ERFÜLLT / CONFORME	<b>CONFORME</b> COMPLIANT / CONFORME ANFORDERUNGEN ERFÜLLT / CONFORME
 <b>CONFORME</b> COMPLIANT / CONFORME ANFORDERUNGEN ERFÜLLT / CONFORME	<b>CONFORME</b> COMPLIANT / CONFORME ANFORDERUNGEN ERFÜLLT / CONFORME
 <b>CONFORME</b> COMPLIANT / CONFORME ANFORDERUNGEN ERFÜLLT / CONFORME	<b>CONFORME</b> COMPLIANT / CONFORME ANFORDERUNGEN ERFÜLLT / CONFORME
 <b>CONFORME</b> COMPLIANT / CONFORME ANFORDERUNGEN ERFÜLLT / CONFORME	<b>CONFORME</b> COMPLIANT / CONFORME ANFORDERUNGEN ERFÜLLT / CONFORME
	<b>R10</b> 60x120 - 60x60 - 30x60 <b>R11</b> 60x60 K2
	<b>R10</b> 60x60 - 30x60
	<b>A+B</b> Structured R10 / <b>A+B+C</b> Structured R11
 <b>CONFORME</b> COMPLIANT / CONFORME ANFORDERUNGEN ERFÜLLT / CONFORME	<b>CONFORME</b> COMPLIANT / CONFORME ANFORDERUNGEN ERFÜLLT / CONFORME
	<b>CONFORME</b> COMPLIANT / CONFORME ANFORDERUNGEN ERFÜLLT / CONFORME
	<b>&gt;36</b> In test
	-

# CLASSIFICAZIONE NON-SLIP

ANTI-SLIP CLASSIFICATION / CLASSIFICATION NON-SLIP / NON-SLIP KLASSIFIZIERUNG / CLASIFICACIÓN NON-SLIP

COLLEZIONI COLLECTIONS COLLECTIONS KOLLEKTIONEN COLECCIONES	SUPERFICIE SURFACE SURFACE OBERFLÄCHE SUPERFICIE	METODO DELLA RAMPA CALZATO (DIN 51130) SHOD RAMP TEST METHODE DE RAMPE CHAUSSÉ BESCHLAGEN RAMP TEST PRUEBA DE RAMPA CALZADO				METODO DELLA RAMPA A PIEDI NUDI (DIN 51097) BAREFOOT RAMP TEST METHODE DE RAMPE PIEDS NUS BARFUSS RAMP TEST PRUEBA DE RAMPA DESCALZO			COEFFICIENTE DI ATTRITO COF (B.C.R.A) COEFFICIENT OF FRICTION COF COEFFICIENT DE FRICTION COF REIBUNGSKOEFFIZIENT COF COEFICIENTE DE FRICCIÓN COF	COEFFICIENTE DI ATTRITO DINAMICO DCOF (ANSI A 137.1-2012) DYNAMIC COEFFICIENT OF FRICTION DCOF / COEFFICIENT DYNAMIQUE DE FRICTION DCOF / DYNAMISCHER KOEFFIZIENT DER REIBUNG DCOF / DYNAMIC COEFFICIENTE DINÁMICO DE FRICCIÓN DCOF
		R9	R10	R11	R12	A	A+B	A+B+C	> 0,40 wet	> 0,42 wet
9CENTO	Lappato	-	-	-	-	-	-	-	-	-
ALPI	Structured								conforme / compliant	conforme / compliant
ARAN	Structured								conforme / compliant	conforme / compliant
ARTEMIS	Natural								conforme / compliant	conforme / compliant
	Structured								conforme / compliant	conforme / compliant
BACK	Natural								conforme / compliant	conforme / compliant
	Structured								conforme / compliant	conforme / compliant
	Grip								conforme / compliant	conforme / compliant
BEAT	Natural								conforme / compliant	conforme / compliant
	Structured								conforme / compliant	conforme / compliant
	Grip								conforme / compliant	conforme / compliant
BRYSTONE	Natural								conforme / compliant	conforme / compliant
	Structured								conforme / compliant	conforme / compliant
CHORUS	Natural								conforme / compliant	conforme / compliant
	Grip								conforme / compliant	conforme / compliant
DOLMIX	Natural								conforme / compliant	conforme / compliant
	Structured								conforme / compliant	conforme / compliant
ECLECTIC	Natural								conforme / compliant	conforme / compliant
	Lappato	-	-	-	-	-	-	-	-	-
	Silky	-	-	-	-	-	-	-	-	-
ELEMENTS DESIGN	Natural								conforme / compliant	conforme / compliant
	Structured								conforme / compliant	conforme / compliant
	Lappato	-	-	-	-	-	-	-	-	-
	Glossy	-	-	-	-	-	-	-	-	-
	3D	-	-	-	-	-	-	-	-	-
ELEMENTS LUX	Natural								conforme / compliant	conforme / compliant
	Lappato	-	-	-	-	-	-	-	-	-
EVOKE	Natural								conforme / compliant	conforme / compliant
	Structured								conforme / compliant	conforme / compliant
GRANIGLIATI LINEA TECNICA	Natural								conforme / compliant	conforme / compliant
	Grip+Struct.								conforme / compliant	conforme / compliant
IKON	Natural								conforme / compliant	conforme / compliant
	Grip								conforme / compliant	conforme / compliant
INTERNO4	Natural								conforme / compliant	conforme / compliant
	Lappato	-	-	-	-	-	-	-	-	-
K-COLOR	Natural	-	-	-	-	-	-	-	-	-
	Grip								conforme / compliant	conforme / compliant
LIMES	Structured								conforme / compliant	conforme / compliant
MIDLAKE	Structured								conforme / compliant	conforme / compliant

<b>BS 7976-2:2002 (UK)</b> (Pendulum Test Value) <b>PTV 96 R10 &gt;36</b> <b>CURSORE BAGNATO</b> SLIDER WET CURSEUR HUMIDE SCHIEBER NASS CONTROL DESLIZANTE MOJADO  <b>&gt; 36</b>
---

60x120 Walnut/Grey/ Silver/Anthracite	30x120 Walnut/Grey/ Silver/Anthracite	60x60 Walnut/Grey/ Silver/Anthracite	30x60 Walnut/Grey/ Silver/Anthracite	9,7x60 Walnut/Grey/ Silver/Anthracite
--	--	---	---	--

20x120 Brown/Ivory/ Grey/Taupe/Walnut
--

60x120 White/Ivory/ Gold/Avana	60x60 White/Ivory/ Gold/Avana	30x60 White/Ivory/ Gold/Avana
60x120 Tobacco/Silver/ Beige/Grey/White	60x60 Tobacco/Silver/ Beige/Grey/White	30x60 Tobacco/Silver/ Beige/Grey/White

60x120 Ivory/Taupe/ Silver/Grey/Black	60x60 Ivory/Taupe/ Silver/Grey/Black	30x60 Ivory/Taupe/ Silver/Grey/Black
--	---	---

120x120 Grey/White/Sky	60x120 Grey/Silver/ White/Sky/Beige	30x120 Grey/Silver/ White/Sky/Beige	60x60 Grey/Silver/ White/Sky/Beige	30x60 Grey/Silver/ White/Sky/Beige	9,7x60 Grey/Silver/ White/Sky/Beige
---------------------------	--	--	---------------------------------------	---------------------------------------	--

in test

## CLASSIFICAZIONE NON-SLIP

ANTI-SLIP CLASSIFICATION / CLASSIFICATION NON-SLIP / NON-SLIP KLASSIFIZIERUNG / CLASIFICACIÓN NON-SLIP

COLLEZIONI COLLECTIONS COLLECTIONS KOLLEKTIONEN COLECCIONES	SUPERFICIE SURFACE SURFACE OBERFLÄCHE SUPERFICIE	METODO DELLA RAMP CALZATO (DIN 51130) SHOD RAMP TEST METHODE DE RAMPE CHAUSSE BESCHLAGEN RAMP TEST PRUEBA DE RAMP CALZADO	METODO DELLA RAMP A PIEDI NUDI (DIN 51097) BAREFOOT RAMP TEST METHODE DE RAMPE PIEDS NUS BARFUSS RAMP TEST PRUEBA DE RAMP DESCALZO	COEFFICIENTE DI ATTRITO COF (B.C.R.A) COEFFICIENT OF FRICTION COF COEFFICIENT DE FRICTION COF REIBUNGSKOEFFIZIENT COF COEFICIENTE DE FRICCIÓN COF			COEFFICIENTE DI ATTRITO DINAMICO DCOF (ANSI A 137.1-2012) DYNAMIC COEFFICIENT OF FRICTION DCOF / COEFFICIENT DYNAMIQUE DE FRICTION DCOF / DYNAMISCHER KOEFFIZIENT DER REIBUNG DCOF / DYNAMIC COEFICIENTE DINÁMICO DE FRICCIÓN DCOF			
				R9	R10	R11	R12	A	A+B	A+B+C
MOOV	Natural								conforme / compliant	conforme / compliant
	Structured								conforme / compliant	conforme / compliant
	Grip								conforme / compliant	conforme / compliant
NOORD	Natural								conforme / compliant	conforme / compliant
	Grip								conforme / compliant	conforme / compliant
PERCORSI EXTRA	Natural								conforme / compliant	conforme / compliant
	Structured								conforme / compliant	conforme / compliant
PERCORSI QUARTZ	Natural								conforme / compliant	conforme / compliant
	Structured								conforme / compliant	conforme / compliant
PERCORSI SMART	Natural								conforme / compliant	conforme / compliant
	Structured								conforme / compliant	conforme / compliant
SIGHT	Structured								conforme / compliant	conforme / compliant
SOUL	Structured								conforme / compliant	conforme / compliant
SUNRISE	Grip								conforme / compliant	conforme / compliant
UBIK	Natural								conforme / compliant	conforme / compliant
	Structured								conforme / compliant	conforme / compliant

BS 7976-2:2002 (UK) (Pendulum Test Value) PTV 96 R10 >36 CURSORE BAGNATO SLIDER WET CURSEUR HUMIDE SCHIEBER NASS CONTROL DESLIZANTE MOJADO
> 36

120x120 Grey/Anthracite/ Moka/Ivory	60x120 Grey/Anthracite/ Moka/Ivory	60x60 Grey/Anthracite/ Moka/Ivory	30x60 Grey/Anthracite/ Moka/Ivory
120x120 Anthracite/ Grey/Taupe/Gold/White	60x120 Anthracite/Grey/ Taupe/Gold/White	30x120 Anthracite/Grey/ Taupe/Gold/White	80x80 Anthracite/Grey/ Taupe/Gold/White
60x60 Anthracite/Grey/ Taupe/Gold/White	30x60 Anthracite/Grey/ Taupe/Gold/White	9,7x60 Anthracite/Grey/ Taupe/Gold/White	

60x120 Pietra di Vals/Pietra di Barge/ Pietra di Faedis	60x60 Pietra di Vals/Pietra di Barge/ Pietra di Faedis	30x60 Pietra di Vals/Pietra di Barge/ Pietra di Faedis
--	---	---

60x120 Quartz/Golden/ Smoke/Cabernet	60x60 Quartz/Golden/ Smoke/Cabernet	30x60 Quartz/Golden/ Smoke/Cabernet
120x120 Anthracite/ Grey/Ivory	60x120 Anthracite/Grey/ Ivory/Greige/Walnut	30x120 Anthracite/Grey/ Ivory/Greige/Walnut
60x60 Anthracite/Grey/ Ivory/Greige/Walnut	30x60 Anthracite/Grey/ Ivory/Greige/Walnut	9,7x60 Anthracite/Grey/ Ivory/Greige/Walnut

## Contract

### CLASSIFICAZIONE NON-SLIP

ANTI-SLIP CLASSIFICATION / CLASSIFICATION NON-SLIP / NON-SLIP KLASSIFIZIERUNG / CLASIFICACIÓN NON-SLIP

COLLEZIONI COLLECTIONS COLLECTIONS KOLLEKTIONEN COLECCIONES	SUPERFICIE SURFACE SURFACE OBERFLÄCHE SUPERFICIE	METODO DELLA RAMP CALZATO (DIN 51130) SHOD RAMP TEST METHODE DE RAMPE CHAUSSE BESCHLAGEN RAMP TEST PRUEBA DE RAMP CALZADO	METODO DELLA RAMP A PIEDI NUDI (DIN 51097) BAREFOOT RAMP TEST METHODE DE RAMPE PIEDS NUS BARFUSS RAMP TEST PRUEBA DE RAMP DESCALZO	COEFFICIENTE DI ATTRITO COF (B.C.R.A) COEFFICIENT OF FRICTION COF COEFFICIENT DE FRICTION COF REIBUNGSKOEFFIZIENT COF COEFICIENTE DE FRICCIÓN COF			COEFFICIENTE DI ATTRITO DINAMICO DCOF (ANSI A 137.1-2012) DYNAMIC COEFFICIENT OF FRICTION DCOF / COEFFICIENT DYNAMIQUE DE FRICTION DCOF / DYNAMISCHER KOEFFIZIENT DER REIBUNG DCOF / DYNAMIC COEFICIENTE DINÁMICO DE FRICCIÓN DCOF			
				R9	R10	R11	R12	A	A+B	A+B+C
CODE	Natural								conforme / compliant	conforme / compliant
DUNSTONE	Natural								conforme / compliant	conforme / compliant
EXTREME	Structured								conforme / compliant	conforme / compliant
LONDALE	Natural								conforme / compliant	conforme / compliant
POINT	Structured								conforme / compliant	conforme / compliant
SKYWALL	Structured								conforme / compliant	conforme / compliant
SWISSTONE	Structured								conforme / compliant	conforme / compliant
URBAN	Grip								conforme / compliant	conforme / compliant

BS 7976-2:2002 (UK) (Pendulum Test Value) PTV 96 R10 >36 CURSORE BAGNATO SLIDER WET CURSEUR HUMIDE SCHIEBER NASS CONTROL DESLIZANTE MOJADO
> 36

in test







## MISURE, PESI ED IMBALLI

SIZE, WEIGHT AND PACKAGING / FORMATS, POIDS ET EMBALLAGES / MASSE, GEWICHTE UND VERPACKUNGEN / MEDIDAS, PESOS Y EMBALAJES

COLLEZIONI COLLECTIONS COLLECTIONS KOLLEKTIONEN COLECCIONES	FORMATO SIZE FORMAT FORMAT FORMATO	SPESSORE THICKNESS ÉPAISSEUR STARKE ESPESOR	PZ/SCATOLA PIECES/BOX PIÈCES/BÔITE STÜCK/KARTON PZAS/CAJA	MQ/SCATOLA SQ. MT./BOX M²/BÔITE QM./KARTON MQ/CAJA	KG/SCATOLA KG/BOX KG/BÔITE KG/KARTON KG/CAJA	MQ/PALLET SQM./PALLET M2/PALETTE QM./PALETTE MQ/PALLET	KG/PALLET KG/PALLET KG/PALETTE KG/PALETTE KG/PALLET	SCATOLA/PALLET BOX/PALLET BÔITE/PALETTE KARTON/PALETTE CAJA/PALLET
PERCORSI EXTRA	120x240 K2	20 mm	1	2,86	≈ 134,20	25,70	≈ 1.307,80	9
	120x120 K2	20 mm	1	1,43	≈ 67,10	28,56	≈ 1.228,00	20
	60x120 K2	20 mm	1	0,72	≈ 33,40	25,20	≈ 1.182,00	35
	30x120 K2	20 mm	2	0,72	≈ 33,05	25,92	≈ 1.202,80	36
	45x90 K2	20 mm	2	0,81	≈ 37,40	21,87	≈ 1.022,80	27
	80x80 K2	20 mm	1	0,64	≈ 29,70	26,88	≈ 1.260,40	42
	60x60 K2	20 mm	2	0,72	≈ 33,80	21,60	≈ 1.027,00	30
	60x60 K3	30 mm	1	0,36	≈ 23,68	14,40	≈ 960,20	40
	7,2x60 battiscopa	9 mm	10	ml 6,00	≈ 10,22	480,00	≈ 830,60	80*
PERCORSI QUARTZ	60x60	9 mm	3	1,08	≈ 25,00	43,20	≈ 1.013,00	40
	30x60	9 mm	7	1,26	≈ 25,00	50,40	≈ 1.013,00	40
	60x60 K2	20 mm	2	0,72	≈ 33,80	21,60	≈ 1.027,00	30
	7,2x60 battiscopa	9 mm	10	ml 6,00	≈ 10,22	480,00	≈ 830,60	80*
PERCORSI SMART	60x60	9 mm	3	1,08	≈ 25,00	43,20	≈ 1.013,00	40
	30x60	9 mm	7	1,26	≈ 25,00	50,40	≈ 1.013,00	40
	15x30 Not RT	9 mm	26	1,17	≈ 22,52	51,48	≈ 1.003,88	44
	120x240 K2	20 mm	1	2,86	≈ 134,20	25,70	≈ 1.307,80	9
	30x240 K2	20 mm	1	0,72	≈ 31,00	25,81	≈ 1.216,00	36***
	120x120 K2	20 mm	1	1,43	≈ 67,10	28,56	≈ 1.355,00	20
	45x90 K2	20 mm	2	0,81	≈ 37,40	21,87	≈ 1.022,80	27
	60x60 K2	20 mm	2	0,72	≈ 33,80	21,60	≈ 1.027,00	30
	60x60 K3	30 mm	1	0,36	≈ 23,68	14,40	≈ 960,20	40
	7,2x60 battiscopa	9 mm	10	ml 6,00	≈ 10,22	480,00	≈ 830,60	80*
	SIGHT	60x60 K2	20 mm	2	0,72	≈ 34,00	21,60	≈ 1.033,00
SOUL	30x120 K2	20 mm	2	0,72	≈ 31,00	25,92	≈ 1.129,00	36
SUNRISE	60x120	9 mm	2	1,44	≈ 33,40	50,40	≈ 1.182,00	35
	60x60	9 mm	3	1,08	≈ 25,00	43,20	≈ 1.013,00	40
	30x60	9 mm	7	1,26	≈ 25,00	50,40	≈ 1.013,00	40
	7,2x60 battiscopa	9 mm	10	ml 6,00	≈ 10,22	480,00	≈ 830,60	80*
	UBIK	120x120	9 mm	2	2,86	≈ 60,80	57,12	≈ 1.229,00
60x120		9 mm	2	1,44	≈ 27,56	50,40	≈ 977,60	35
30x120		9 mm	4	1,44	≈ 30,50	51,84	≈ 1.111,00	36
60x60		9 mm	3	1,08	≈ 25,00	43,20	≈ 1.013,00	40
30x60		9 mm	7	1,26	≈ 27,76	50,40	≈ 1.123,40	40
9,7x60		9 mm	10	0,58	≈ 12,75	34,92	≈ 778,00	60
60x120		20 mm	1	0,72	≈ 33,75	25,20	≈ 1.194,25	35
60x60		20 mm	2	0,72	≈ 34,00	21,60	≈ 1.033,00	30
4,6x120 battiscopa		9 mm	6	ml 7,20	≈ 7,80	345,60	≈ 387,40	48*
7,2x60 battiscopa		9 mm	10	ml 6,00	≈ 10,48	480,00	≈ 851,40	80*

\* Venduti a scatole complete / Full boxes sold / Vendus par boîte complete / Volle Karton / Vendido para cajas completas

\*\* Venduto a multipli di 4 pezzi / Sold in multiples of 4 pieces/ Vendu seulement par multiples de 4 pièces / Nur in Vielfachen von 4 Stück verkauft / Se venden en múltiplos de 4 unidades

## Contract

## MISURE, PESI ED IMBALLI

SIZE, WEIGHT AND PACKAGING / FORMATS, POIDS ET EMBALLAGES / MASSE, GEWICHTE UND VERPACKUNGEN / MEDIDAS, PESOS Y EMBALAJES

COLLEZIONI COLLECTIONS COLLECTIONS KOLLEKTIONEN COLECCIONES	FORMATO SIZE FORMAT FORMAT FORMATO	SPESSORE THICKNESS ÉPAISSEUR STARKE ESPESOR	PZ/SCATOLA PIECES/BOX PIÈCES/BÔITE STÜCK/KARTON PZAS/CAJA	MQ/SCATOLA SQ. MT./BOX M²/BÔITE QM./KARTON MQ/CAJA	KG/SCATOLA KG/BOX KG/BÔITE KG/KARTON KG/CAJA	MQ/PALLET SQM./PALLET M2/PALETTE QM./PALETTE MQ/PALLET	KG/PALLET KG/PALLET KG/PALETTE KG/PALETTE KG/PALLET	SCATOLA/PALLET BOX/PALLET BÔITE/PALETTE KARTON/PALETTE CAJA/PALLET
CODE	60x120	9 mm	2	1,44	≈ 31,93	50,40	≈ 1.135,10	35
	60x60	8,5 mm	3	1,08	≈ 22,95	43,20	≈ 931,00	40
	30x60	8,5 mm	7	1,26	≈ 26,77	50,40	≈ 1.083,80	40
	7,2x60 battiscopa	8,5 mm	10	ml 6,00	≈ 10,48	480,00	≈ 851,40	80*
DUNSTONE	60x120	9 mm	2	1,44	≈ 33,40	50,40	≈ 1.182,00	35
	60x60	8,5 mm	3	1,08	≈ 25,00	43,20	≈ 1.013,00	40
	30x60	8,5 mm	7	1,26	≈ 25,00	50,40	≈ 1.013,00	40
	7,2x60 battiscopa	8,5 mm	10	ml 6,00	≈ 10,29	480,00	≈ 836,20	80*
EXTREME	45x90 K2	20 mm	2	0,81	≈ 36,14	21,87	≈ 988,78	27
	60x60 K2	20 mm	2	0,72	≈ 33,73	21,60	≈ 1.024,90	30
LONDALE	60x120	9 mm	2	1,44	≈ 33,40	50,40	≈ 1.182,00	35
	60x60	8,5 mm	3	1,08	≈ 25,00	43,20	≈ 1.013,00	40
	30x60	8,5 mm	7	1,26	≈ 25,00	50,40	≈ 1.013,00	40
	7,2x60 battiscopa	8,5 mm	10	ml 6,00	≈ 10,29	480,00	≈ 836,20	80*
POINT	30x60 Not RT	8,5 mm	7	1,26	≈ 25,00	50,40	≈ 1.013,00	40
	30x30 Not RT	8,5 mm	12	1,08	≈ 21,00	47,52	≈ 937,00	44
	15x30 Not RT	8,5 mm	24	1,08	≈ 20,49	47,52	≈ 914,56	44
	8x30 Not RT battiscopa	8,5 mm	33	ml 9,90	≈ 17,00	633,60	≈ 1.101,00	64*
	SKYWALL	60x60 K2	20 mm	2	0,72	≈ 32,90	21,60	≈ 1.000,00
SWISSSTONE	60x120	9 mm	2	1,44	≈ 33,40	50,40	≈ 1.182,00	35
	60x60	8,5 mm	3	1,08	≈ 25,00	43,20	≈ 1.013,00	40
	30x60	8,5 mm	7	1,26	≈ 25,00	50,40	≈ 1.013,00	40
	7,2x60 battiscopa	8,5 mm	10	ml 6,00	≈ 10,29	480,00	≈ 836,20	80*
URBAN	60x60	8,5 mm	3	1,08	≈ 20,87	43,20	≈ 847,80	40
	30x60	8,5 mm	7	1,26	≈ 25,00	50,40	≈ 1.013,00	40
	7,2x60 battiscopa	8,5 mm	10	ml 6,00	≈ 10,48	480,00	≈ 851,40	80*

\*\*\* Ordine minimo 25,81mq / Minimum order quantity 25,81 sqm / Commande minimum 25,81 mq / Mindestbestellmenge 25,81 mq / Pedido minimo 25,81 mq

# CERTIFICAZIONI/ CERTIFICATION /

CERTIFICATION / ZERTIFIZIERUNG / CERTIFICACIÓN

IT\_

Keope è una delle aziende oggi più attente alle qualità ecologiche dell'industria ceramica. Grazie all'efficiente e moderno stabilimento produttivo, è stata nel 2004 la prima azienda ceramica che ha completato il percorso di verifica e riduzione delle proprie emissioni di CO2 e gas ad effetto serra, in ottemperanza a quanto stabilito dal protocollo di Kyoto, dando il via ad una serie di importanti iniziative volte e migliorare l'efficienza complessiva dell'Azienda.

Il consistente investimento di capitali e risorse umane non è solo finalizzato ad una produzione di elevato livello tecnologico, ma a garantire un ciclo di fabbricazione che si svolga nel pieno rispetto dell'uomo e dell'ambiente. Macchine e impianti sono dotati dei più moderni sistemi di sicurezza, la cui efficienza è verificata periodicamente. Nello stabilimento KEOPE si curano la depurazione delle emissioni gassose secondo le normative vigenti, il completo riutilizzo di acque e scarti solidi di lavorazione e la raccolta differenziata di tutti gli altri rifiuti. Presso lo stabilimento è installato inoltre un impianto di cogenerazione che limita le esigenze energetiche, garantendo un basso contenuto di emissioni nocive.

FR\_

*Keope est une des entreprises actuellement les plus sensibles aux qualités écologiques de l'industrie de la céramique. Grâce à l'efficacité et à la modernité de son établissement de production, en 2004 elle a été la première entreprise de céramique à compléter le parcours de vérification et réduction des émissions de CO2 et gaz à effet de serre, dans le respect du protocole de Kyoto, entamant une série d'importantes initiatives visant à améliorer l'efficacité globale de l'entreprise.*

*L'investissement consistant de capitaux et de ressources humaines n'a pas uniquement pour but une production technologiquement avancée, mais aussi celui de garantir un cycle de fabrication se déroulant dans le plein respect de l'homme et de l'environnement. Les machines et les installations sont équipées des systèmes de sécurité les plus modernes, dont l'efficacité est vérifiée régulièrement. Au sein de l'établissement KEOPE, on s'occupe d'éliminer les émissions gazeuses selon les normes en vigueur, de réutiliser totalement les eaux et déchets solides issus de la production et de réaliser le tri sélectif de tous les autres déchets. L'établissement comprend également une installation de cogénération limitant les exigences énergétiques et garantissant un faible contenu d'émissions nocives.*

EN\_

*Keope is actually one of the companies with the higher attention level to the ecological characteristics in the tile industry. As a result of its efficient and modern production plant, Ceramiche Keope in 2004 has become the first ceramic tile company to have fully implemented a system to control and reduce emissions of carbon dioxide and other greenhouse gases, in compliance with the directives of the Kyoto protocol. Ceramiche Keope confirmed its commitment to an environment friendly policy, by attaining UNI ISO 14064 certification for the enforcement of the Kyoto Protocol in September 2007 and therefore becoming the first European and the world's first ceramic industry to do so.*

*The considerable financial and human resource investments made are not only directed to high-tech production, but also to ensure a manufacturing cycle that fully respects man and his environment. Machines and installations are equipped with the most modern safety systems that are periodically checked for efficiency. In KEOPE's factory, the purification of gaseous emissions, the complete reutilization of water, solid processing rejects and the differentiated collection of all waste material are effectuated in accordance with the standards in force. Furthermore, a cogeneration installation has been installed in the factory that limits energy needs, ensuring a low content of harmful emissions.*

DE\_

*Keope ist heute eines der umweltbewusstesten Unternehmen der Keramikindustrie. Dank seiner effizienten und modernen Produktionsanlage hat es 2004 als erstes Keramikunternehmen den Prozess der Überprüfung und Reduzierung seiner CO2- und Treibhausgasemissionen gemäß den Bestimmungen des Kyoto-Protokolls abgeschlossen und eine Reihe wichtiger Initiativen zur Verbesserung der Gesamteffizienz des Unternehmens eingeleitet. Die erheblichen Investitionen in Kapital und Humanressourcen zielen nicht nur auf eine Produktion auf hohem technologischem Niveau ab, sondern auch auf die Sicherstellung eines Produktionszyklus, der unter voller Achtung von Mensch und Umwelt stattfindet. Maschinen und Anlagen sind mit modernsten Sicherheitssystemen ausgestattet, deren Effizienz regelmäßig überprüft wird. Im Werk von KEOPE werden gasförmige Emissionen aus den Anlagen gemäß den geltenden Vorschriften gereinigt, Wasser und feste Verarbeitungsabfälle vollständig wiederverwendet und alle anderen Abfälle getrennt gesammelt. Darüber hinaus ist im Produktionswerk ein Blockheizkraftwerk installiert, das den Energiebedarf begrenzt und einen niedrigen Schadstoffausstoß garantiert.*

ES\_

*Keope es una de las empresas que más atención presta en la actualidad al aspecto ecológico de la industria cerámica. Gracias a sus instalaciones de producción modernas y eficaces, en 2004 se convirtió en la primera empresa cerámica en completar el proceso de verificación y reducción de las emisiones de CO2 y de gases de efecto invernadero conforme a lo estipulado en el protocolo de Kioto, a raíz del cual se pusieron en marcha una serie de iniciativas importantes dirigidas a mejorar la eficiencia general de la empresa.*

*La inversión permanente de capital y recursos humanos no solo está orientada a lograr una producción de alto nivel tecnológico, sino también a garantizar un ciclo de producción que se desarrolle con pleno respeto por el ser humano y el medio ambiente. Las máquinas y las instalaciones disponen de los sistemas de seguridad más modernos, cuya eficacia se comprueba periódicamente. En la planta de KEOPE se lleva a cabo la purificación de gases de escape según la normativa actualmente en vigor, además de la reutilización de aguas residuales y residuos sólidos de fabricación y la recogida diferenciada de todos los demás residuos. En la planta existe una instalación de cogeneración que limita la demanda energética, lo que se garantiza un nivel bajo de emisiones perjudiciales.*

# CERTIFICAZIONI DI PROCESSO/ PROCESS CERTIFICATIONS /

CERTIFICATION DE PROCESSUS / PROZESSZERTIFIZIERUNG / CERTIFICACIÓN DE PROCESO

## UNI EN ISO 9001

IT\_

Azienda certificata per la progettazione, produzione vendita di piastrelle ceramiche in gres fine porcellanato secondo la **norma iso 9001**.

FR\_

*Firme certifiée pour la conception du projet, la production et la vente de carreaux de céramique en gres fin avec fini porcelaine selon la norme iso 9001.*

EN\_

*Major company whose design, production and sale of fully vitrified porcelain tiles has been certified under iso 9001 standards.*

DE\_

*Unternehmen mit zertifizierung für die entwicklung, die Produktion und den verkauf von Fliesen und Platten aus feinsteinzeug nach iso 9001.*

ES\_

*empresa certificada para la proyectacion, produccion y venta de azulejos ceramicos de gres fino a porcelanado segun la norma iso 9001.*



## OHSAS 18001

(Occupational Health and Safety Assessment Series)

IT\_

Ceramiche Keope ha ottenuto recentemente la Certificazione OHSAS 18001. Si tratta di uno standard per la gestione della salute e della sicurezza dei lavoratori che permette alle imprese di attuare un controllo responsabile dei rischi e aumentare costantemente la tutela e il benessere sui luoghi di lavoro, al fine di proteggere il personale da eventuali pericoli.

FR\_

*Ceramiche Keope a récemment obtenu la Certification OHSAS 18001. Il s'agit d'une norme de management de la santé et de la sécurité au travail, qui permet aux entreprises de mettre en place un contrôle responsable des risques et d'améliorer sans cesse la protection et le bien-être sur les lieux de travail, afin de protéger le personnel contre d'éventuels dangers.*

EN\_

*Ceramiche Keope has been OHSAS 18001 certified recently. It is a standard for the management of the health and safety of workers that allows companies to implement responsible control of risks and constantly increase the protection and well-being in the workplace, in order to protect staff from any dangers.*

DE\_

*Ceramiche Keope hat kürzlich die OHSAS 18001 Zertifizierung erhalten. Es handelt sich um eine Norm für das Management der Gesundheit und Sicherheit der Arbeitnehmer, die es den Unternehmen ermöglicht, eine verantwortungsvolle Kontrolle der Risiken durchzuführen und den Schutz und das Wohlbefinden am Arbeitsplatz ständig zu erhöhen und das Personal entsprechend vor Gefahren zu schützen.*

ES\_

*Ceramiche Keope ha obtenido recientemente la Certificación OHSAS 18001. Se trata de un estándar para la gestión de la seguridad y la salud de los trabajadores que permite a las empresas implementar un control responsable de riesgos y aumentar constantemente la protección y el bienestar en el lugar de trabajo, a fin de proteger al personal de cualquier posible peligro.*



# CERTIFICAZIONI DI PRODOTTO/ PRODUCTS CERTIFICATION /

CERTIFICATION DE PRODUIT / PRODUKTZERTIFIZIERUNG / CERTIFICACIÓN DE PRODUCTO

## DOP/CE

### IT\_

La marcatura CE è la certificazione di sicurezza del prodotto richiesta dall'Unione Europea ed ha lo scopo di salvaguardare la salute delle persone e i beni nelle opere di costruzione. Il nuovo Regolamento UE N. 305/2011 ha introdotto la Dichiarazione di Prestazione (DOP, Declaration of Performance) con la quale il fabbricante comunica i requisiti di sicurezza dei propri materiali. Le DoP delle collezioni di Ceramiche Keope sono disponibili all'indirizzo [keope.com](http://keope.com)

### EN\_

*The CE mark is the safety product certification required by EU and it is finalized to preserve the people's health and the goods in buildings. The new Regulation UE N. 305/2011 is valid from the first of July 2013 and the most important news is the introduction of the Declaration Of Performance (DOP) with which the supplier communicates the safety requirements concerning own materials. Find the conformity of the collections of Ceramiche Keope at [keope.com](http://keope.com)*

### FR\_

*Le marquage CE est la certification de sécurité du produit exigée par l'Union européenne et qui a pour but de protéger la santé des personnes et des biens dans les œuvres de construction. Le nouveau règlement UE N. 305/2011 a introduit la Déclaration de Performance (DOP, Declaration of Performance), à travers laquelle le fabricant communique les conditions de sécurité de ses matériaux. Les DoP des collections de Ceramiche Keope sont disponibles à l'adresse [keope.com](http://keope.com)*

### DE\_

*Die CE-Kennzeichnung ist die von der Europäischen Union geforderte Produktsicherheitszertifizierung und hat zum Ziel, die Gesundheit von Menschen und Gütern bei Bauarbeiten zu schützen. Mit der neuen EU-Verordnung Nr. 305/2011 wurde die Leistungserklärung (DOP) eingeführt, mit der der Hersteller die Sicherheitsanforderungen an seine Materialien kommuniziert. Die DoPs der Kollektionen von Ceramiche Keope sind unter folgender Adresse [keope.com](http://keope.com) einsehbar.*

### ES\_

*La finalidad de la marca CE y de la certificación de seguridad del producto que exige la Unión Europea es preservar la salud de las personas y los bienes materiales en las obras de construcción. El nuevo Reglamento 305/2011 de la UE introduce la Declaración de prestaciones (DOP, Declaration of Performance) con la que el fabricante comunica los requisitos de seguridad de sus propios materiales. La DOP de las colecciones de Ceramiche Keope se encuentra disponible en la dirección [keope.com](http://keope.com)*

## CCC

### IT\_

Il certificato cinese obbligatorio, comunemente noto come marchio CCC (China Compulsory Certificate), è un marchio di sicurezza obbligatorio per molti prodotti venduti sul mercato cinese. È diventato effettivo il 1° maggio 2002.

### EN\_

*The China Compulsory Certificate mark, commonly known as a CCC Mark, is a compulsory safety mark for many imported products, sold in the Chinese market. It was implemented on May 1, 2002.*

### FR\_

*Le certificat chinois obligatoire, connu comme label CCC (China Compulsory Certificate) est un marquage de sécurité obligatoire pour de nombreux produits vendus sur le marché chinois. Il est devenu effectif le 1er mai 2002.*

### DE\_

*Das obligatorische chinesische Zertifikat, allgemein bekannt als das China Compulsory Certificate (CCC) Zeichen, ist ein obligatorisches Sicherheitszeichen für viele Produkte, die auf dem chinesischen Markt verkauft werden. Es ist am 1. Mai 2002 in Kraft getreten.*

### ES\_

*El certificado chino obligatorio correspondiente a la marca CCC (China Compulsory Certificate) es imprescindible como marca de seguridad en muchos productos que se venden en el mercado chino. Entró en vigor el 1 de mayo de 2002.*



## UPEC

### IT\_

Molti prodotti Keope sono testati e classificati secondo le normative UPEC, al fine di certificarne l'appropriatezza rispetto alle destinazioni d'uso. I test ai quali sono sottoposte le piastrelle presso il "Centre Scientifique du Bâtiment (CSTB)" - secondo le specifiche normative emanate dal CSTB – sono estremamente selettivi e sono volti a stabilire la resistenza e le performance dei prodotti rispetto a quattro dimensioni fondamentali: resistenza all'usura (U), alla perforazione (P), all'acqua (E) e all'aggressione chimica (C). Le schede Upec delle singole serie sono disponibili all'indirizzo [keope.com/upec](http://keope.com/upec)

### FR\_

*De nombreux produits Keope sont testés et classés selon les normes UPEC, afin d'en certifier l'adéquation aux destinations d'utilisation. Les tests auxquels sont soumis les carreaux auprès du « Centre Scientifique du Bâtiment (CSTB) » – selon les normes spécifiques issues du CSTB – sont extrêmement stricts et visent à établir la résistance et les performances des produits selon quatre axes essentiels : résistance à l'usure (U), à la perforation (P), à l'eau (E) et à l'agression chimique (C). Les fiches Upec de chaque série sont disponibles à l'adresse [keope.com/upec](http://keope.com/upec)*

### EN\_

*Many Keope products are tested and classified according to the UPEC standards, in order to certify their appropriateness with regard to the intended uses. The tests which the tiles undergo at the "Centre Scientifique du Bâtiment (CSTB)" - in accordance with specific rules issued by CSTB - are extremely selective and are aimed at establishing the resistance and performance of the products with respect to four fundamental "dimensions": resistance to wear (U), perforation (P), water (E) and chemical attack (C). UPEC data sheets of the series are available at [keope.com/upec](http://keope.com/upec)*

### DE\_

*Viele Keope-Produkte werden nach den UPEC-Vorschriften geprüft und klassifiziert, um ihre Eignung für den vorgesehenen Einsatzzweck zu bestätigen. Die Prüfungen, denen die Fliesen im „Centre Scientifique du Bâtiment (CSTB)" - gemäß den spezifischen Vorschriften des CSTB - unterzogen werden, sind äußerst selektiv und zielen darauf ab, die Beständigkeit und Leistung der Produkte in Bezug auf vier grundlegende Dimensionen festzustellen: Verschleißfestigkeit (U), Perforation (P), Wasser (E) und chemische Beständigkeit (C). Die Upec-Datenblätter der einzelnen Serien sind unter folgender Adresse [keope.com/upec](http://keope.com/upec) einsehbar.*

### ES\_

*Las pruebas a las que se han sometido muchos de los productos Keope demuestran el cumplimiento de las normativas UPEC, que certifican su adecuación al uso previsto. Las baldosas se someten a pruebas extremadamente selectivas en el "Centre Scientifique du Bâtiment (CSTB)" según normas específicas del CSTB, que están dirigidas a establecer la resistencia y las prestaciones de los productos en cuatro aspectos fundamentales: resistencia al desgaste (U), a la perforación (P), al agua (E) y a la agresión química (C). Las fichas de la UPEC correspondientes a cada serie están disponibles en la dirección [keope.com/upec](http://keope.com/upec)*

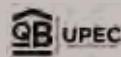

## SASO

### IT\_

Certificato di Conformità per le esportazioni verso l'Arabia Saudita. Per tutte le esportazioni verso l'Arabia Saudita è stato attuato un programma di valutazione della conformità. Tutti i prodotti richiedono un Certificato di Conformità indicato anche come SASO CoC.

### FR\_

*Certificat de Conformité pour les exportations vers l'Arabie Saoudite. Pour toutes les exportations vers l'Arabie Saoudite, un programme d'évaluation de la conformité a été établi. Tous les produits doivent porter un Certificat de Conformité appelé SASO CoC.*

### EN\_

*Certificate of Conformity for Exports to Saudi Arabia. For all exports to the Kingdom of Saudi Arabia a Conformity Assessment Programme has been implemented. All products require a Certificate of Conformity also referred to as SASO CoC.*

### DE\_

*Konformitätsbescheinigung für Exporte nach Saudi-Arabien. Für alle Exporte nach Saudi-Arabien wurde ein Konformitätsbewertungsprogramm durchgeführt. Alle Produkte erfordern eine Konformitätsbescheinigung, die auch SASO CoC genannt wird.*

### ES\_

*Certificado de conformidad para la exportación a Arabia Saudí. Se ha puesto en marcha un programa de evaluación de la conformidad para todas las exportaciones a Arabia Saudí. Todos los productos requieren un certificado de conformidad de SASO (SASO CoC).*



# CERTIFICAZIONI DI PRODOTTO/ PRODUCTS CERTIFICATION /

CERTIFICATION DE PRODUIT / PRODUKTZERTIFIZIERUNG / CERTIFICACIÓN DE PRODUCTO

## EPD

(Environmental Product Declaration)

### IT\_

È uno schema di certificazione volontaria di prodotto, nato in Svezia ma di valenza internazionale, inquadrato dalle norme ISO 14020 e ISO 14025.

Si tratta di una dichiarazione che permette di comunicare informazioni oggettive, confrontabili e credibili relative alla prestazione ambientale dei prodotti di Ceramiche Keope, analizzando l'impatto ambientale a partire dalla fase di estrazione delle materie prime fino alla fine del ciclo di vita ("cradle to grave").

### EN\_

*Is a voluntary certification program, created in Sweden with an international scope, based on the ISO 14020 and ISO 14025 standards.*

*This declaration communications objective, comparable and transparent information about the environmental performance of Keope products. It analyses the environmental impact starting from extraction of raw materials to the end of the product's life-cycle ("from the cradle to the grave").*

### FR\_

*Il s'agit d'un schéma de certification volontaire de produit, né en Suède mais à valeur internationale, encadré par les normes ISO 14020 et ISO 14025.*

*Il s'agit d'une déclaration permettant de communiquer des informations objectives, comparables et crédibles concernant les performances environnementales des produits de Ceramiche Keope, analysant l'impact environnemental à partir de la phase d'extraction des matières premières jusqu'à la fin de cycle de vie ("cradle to grave").*

### DE\_

*Es ist ein freiwilliges Produktzertifizierungssystem, das seinen Ursprung in Schweden hat, aber international an Gültigkeit gewonnen hat und sich auf die Normen ISO 14020 und ISO 14025 bezieht. Es handelt sich um eine Erklärung, die es ermöglicht, objektive, vergleichbare und glaubwürdige Informationen über die Umweltleistung der Produkte von Ceramiche Keope zu vermitteln und die Umweltauswirkungen von der Phase der Rohstoffgewinnung bis zum Ende des Lebens ("cradle to grave") zu analysieren.*

### ES\_

*Se trata de un mecanismo de certificación voluntaria de productos creado en Suecia que tiene validez internacional y que se enmarca en las normas ISO 14020 e ISO 14025. Se trata de una declaración que permite comunicar información objetiva, contrastable y verosímil relacionada con las prestaciones ambientales de los productos de Ceramiche Keope. En ella se analiza la repercusión ambiental desde la fase de extracción de las materias primas hasta el final del ciclo de vida del producto ("cradle to grave").*

## EPD

## PEF

(Product Environmental Footprint)

### IT\_

È un metodo basato sul life cycle assessment (LCA), impiegato al fine di calcolare la performance ambientale di un prodotto lungo il suo intero ciclo di vita. Trae origine dalla Raccomandazione 2013/179/UE della Commissione Europea, che mira ad introdurre metodologie comuni per misurare e comunicare le prestazioni ambientali nel ciclo di vita dei prodotti e delle organizzazioni. Le informazioni relative alla PEF sono fornite con l'obiettivo generale di ridurre gli impatti ambientali dei prodotti Keope, tenendo conto delle attività della catena di approvvigionamento: dall'estrazione di materie prime, alla produzione, all'uso e fine vita del prodotto.

### FR\_

*Il s'agit d'une méthode basée sur le life cycle assessment (LCA), employé afin de calculer la performance environnementale d'un produit durant tout son cycle de vie. Il puise son origine dans la Recommandation 2013/179/CE de la Commission européenne, qui vise à introduire des méthodologies communes pour mesurer et communiquer les performances environnementales dans le cycle de vie des produits et des organisations. Les informations concernant la PEF sont fournies avec l'objectif général de réduire les impacts environnementaux des produits Keope, en tenant compte des activités de la chaîne d'approvisionnement : de l'extraction de matières premières à la production, à l'utilisation et à la fin de vie du produit.*

### EN\_

*Is a method based on life cycle assessment (LCA), and is used to calculate the environmental performance of a product during its entire life-cycle. It has been inspired by the 2013/179/EU Recommendation of the European Commission, which has focussed on implementing common methods for measuring and communicating the environmental performance in the life-cycle of a product and of an organisation. PEF-based information is provided for the general purpose of reducing environmental impact of Keope products, taking account of the entire procurement chain: extraction of raw materials, production, use, end of the product's life-cycle.*

### DE\_

*Es handelt sich um eine auf der Ökobilanz basierende Methode, mit der die Umweltleistung eines Produkts über seinen gesamten Lebenszyklus berechnet wird. Sie geht auf die Empfehlung 2013/179/EU der Europäischen Kommission zurück, die darauf abzielt, gemeinsame Methoden zur Messung und Kommunikation der Umweltleistung im Lebenszyklus von Produkten und Organisationen einzuführen. PEF-Informationen werden mit dem übergeordneten Ziel bereitgestellt, die Umweltauswirkungen von Keope-Produkten unter Berücksichtigung der Aktivitäten der Lieferkette zu verringern: von der Gewinnung der Rohstoffe über die Herstellung, Verwendung und das Ende der Lebensdauer des Produkts.*

### ES\_

*Es un método basado en el análisis del ciclo de vida (life cycle assessment, LCA) que sirve para determinar el impacto ambiental de un producto durante su ciclo de vida completo. Se basa en la Recomendación 2013/179/UE de la Comisión Europea, que está encaminada a introducir metodología común para medir y comunicar el comportamiento ambiental durante el ciclo de vida de los productos y las organizaciones. Se proporciona información relativa a PEF con el objetivo de reducir el impacto ambiental de los productos Keope teniendo en cuenta la cadena de suministro: desde la extracción de materias primas hasta la producción, el uso y el final de la vida útil del producto.*

# CERTIFICAZIONI DI PRODOTTO/ PRODUCTS CERTIFICATION /

CERTIFICATION DE PRODUIT / PRODUKTZERTIFIZIERUNG / CERTIFICACIÓN DE PRODUCTO

## FDES

(Fiches de Déclaration Environnementale et Sanitaire)

### IT\_

È una certificazione specifica del mercato francese, divenuta obbligatoria nel settore delle costruzioni a decorrere dal 2017. È progettata per informare i professionisti sulle caratteristiche ambientali e sanitarie dei diversi prodotti da costruzione. Come per EPD e PEF, è un documento standardizzato che presenta i risultati delle analisi del ciclo di vita ed informazioni sulla salute di un prodotto. È un importante strumento per aiutare i professionisti nella scelta di rendere un edificio più sostenibile, con un impatto limitato sull'ambiente. Ceramiche Keope ha ottenuto questa certificazione in collaborazione con l'ente Bureau Veritas.

### EN\_

*Is a certification applying to the French market, which became mandatory for the building sector in 2017. It has been created to inform professionals about the environmental and health-related features of the various kinds of building material. In the same manner as the EPD and the PEF, it is a standardised document that presents the results of an analysis of the life-cycle and information about the healthiness of a product. It is an important tool for helping professionals choose materials that contribute to making a building more sustainable and with a limited impact on the environment. Ceramiche Keope has obtained this certification with the cooperation of Bureau Veritas.*

### FR\_

*Il s'agit d'une certification spécifique du marché français, devenue obligatoire dans le secteur des constructions à partir de 2017. Elle est conçue pour informer les professionnels sur les caractéristiques environnementales et sanitaires des divers produits de construction. Comme pour EPD et PEF, c'est un document normalisé qui présente les résultats des analyses du cycle de vie et des informations sur la santé d'un produit. Il s'agit d'un instrument important pour aider les professionnels dans le choix de rendre un bâtiment plus durable, avec un impact limité sur l'environnement. Ceramiche Keope a obtenu cette certification en collaboration avec l'organisme Bureau Veritas.*

### DE\_

*Es handelt sich um eine spezifische Zertifizierung des französischen Marktes, die im Bausektor ab 2017 verpflichtend wurde. Es soll die Fachleute über die Umwelt- und Gesundheitsmerkmale verschiedener Bauprodukte informieren. Wie bei EPD und PEF handelt es sich um ein standardisiertes Dokument, das die Ergebnisse von Lebenszyklusanalysen und Informationen über die Gesundheit eines Produkts enthält. Es ist ein wichtiges Instrument, um Fachleuten bei der Entscheidung zu helfen, ein Gebäude nachhaltiger zu gestalten, mit begrenzten Auswirkungen auf die Umwelt. Ceramiche Keope hat diese Zertifizierung in Zusammenarbeit mit Bureau Veritas erhalten.*

### ES\_

*Es una certificación específica del mercado francés cuyo cumplimiento se hizo obligatorio para el sector de la construcción a partir del 2017. Está diseñada para informar a los profesionales de las características ambientales y sanitarias de los distintos productos de construcción. Como ocurre con EPD y PEF, se trata de un documento estandarizado que presenta los resultados de los análisis del ciclo de vida junto con información sobre la salud de un producto. Esta importante herramienta sirve de ayuda a los profesionales que optan por la sostenibilidad de un edificio con impacto limitado en el medio ambiente. Ceramiche Keope ha obtenido esta certificación en colaboración con Bureau Veritas.*



## HPD

(Health Product Declaration)

### IT\_

L'open-standard di HPD è stato creato per promuovere la rendicontazione costante delle caratteristiche del prodotto e per presentare le eventuali informazioni di pericolo per la salute di prodotti e materiali da costruzione. Riconosciuto da USGBC LEED, l'Healthy Product Declaration fornisce ai clienti le informazioni necessarie per prendere decisioni di acquisto più informate. Inoltre, l'utilizzo di prodotti con la certificazione HPD aiuta i team di progetto a raggiungere i nuovi crediti LEED@v4 Materials and Resources. Le HPD forniscono informazioni sui rischi per la salute di tutti i soggetti coinvolti nella progettazione, costruzione e allestimento del progetto, e per salvaguardare la salute dell'occupante dell'edificio. I prodotti sono valutati dal produttore utilizzando il Greenscreen List Translator, strumento on-line per lo screening delle sostanze chimiche pericolose. HPD aumenta la trasparenza e la consapevolezza, assicurando che sia il contenuto che le informazioni relative alla salubrità vengano segnalate in modo coerente.

### FR\_

*Les normes ouvertes de HPD ont été créées pour promouvoir l'information constante sur les caractéristiques du produit et pour présenter les éventuelles informations de danger pour la santé de produits et matériaux de construction. Reconnue par USGBC LEED, l'Healthy Product Declaration fournit aux clients les informations nécessaires pour prendre des décisions d'achat plus éclairées. En outre, l'utilisation de produits avec la certification HPD aide les équipes de projet à atteindre les nouveaux crédits LEED@v4 Materials and Resources. Les HPD fournissent des informations sur les risques pour la santé de tous les individus impliqués dans la conception, construction et installation du projet, et pour protéger la santé des personnes occupant l'édifice. Les produits sont évalués par le producteur en utilisant le Greenscreen List Translator, instrument en ligne pour le dépistage des substances chimiques dangereuses. L'HPD augmente la transparence et la conscience, garantissant que le contenu et les informations sur la salubrité sont signalés de manière cohérente.*

### EN\_

*An open-standard for reporting product content. Run by a voluntary, membership industry non-profit, the openstandard HPD was created to promote consistent reporting of product and material content and to produce any health hazard information for building products and materials. Recognized by USGBC LEED standard, the Health Product Declaration provides customers with the information required to make more informed purchase decisions. Additionally, using products with HPDs helps project teams achieve the new LEED@v4 Materials and Resources credit: Building product disclosure and optimization. HPDs provide information regarding health hazards to everyone involved in designing, constructing and outfitting built environments to safeguard the health of building occupant. Products are assessed by manufacturer in-house using the GreenScreen List Translator (LT), online resource to screen for hazardous Benchmark-1 chemicals. HPD increases transparency and accuracy by ensuring that both content and health information is reported consistently.*

### DE\_

*Der Open-standard von HPD wurde geschaffen, um eine kontinuierliche Berichterstattung über die Produkteigenschaften zu fördern und Informationen über Gesundheitsgefährdungen von Bauprodukten und -materialien darzustellen. Die von USGBC LEED anerkannte Healthy Product Declaration liefert den Kunden die Informationen, die sie benötigen, um fundiertere Kaufentscheidungen zu treffen. Darüber hinaus unterstützt der Einsatz von HPD-zertifizierten Produkten die Projektteams bei der Erreichung der neuen LEED@v4 Material- und Ressourcenkredite. HPDs liefern Informationen über die Gesundheitsrisiken aller an der Planung, dem Bau und der Vorbereitung des Projekts Beteiligten und zum Schutz der Gesundheit der Bewohner des Gebäudes. Die Produkte werden vom Hersteller mit Hilfe der Greenscreen List Translator, einem Online-Tool zum Screening gefährlicher Chemikalien, bewertet. HPD erhöht die Transparenz und das Bewusstsein, indem es sicherstellt, dass sowohl Inhalte als auch Gesundheitsinformationen konsistent berichtet werden.*

### ES\_

*El estándar abierto (open-standard) de HPD se ha creado para fomentar la comunicación permanente de las características del producto y presentar la información de peligrosidad para la salud de los productos y los materiales de construcción que pueda haber. La Declaración de Salud de Producto (Healthy Product Declaration, HPD) está reconocida por USGBC LEED y proporciona a los clientes los datos necesarios para tomar decisiones de compra informadas. Además, el uso de productos con certificación HPD ayuda al equipo de diseño a obtener nuevos créditos LEED@v4 en la categoría Materiales y Recursos. En la Declaración de Salud de Producto se proporciona información sobre los riesgos para la salud de todas las personas involucradas en el diseño, la construcción y la implantación del proyecto, así como para proteger la salud de los ocupantes del edificio. El fabricante analiza los productos mediante el uso de una herramienta interactiva de detección de sustancias químicas peligrosas denominada Greenscreen List Translator. La HPD fomenta la transparencia y la concienciación porque garantiza una representación coherente del contenido y de la información.*



# CERTIFICAZIONI DI PRODOTTO/ PRODUCTS CERTIFICATION /

CERTIFICATION DE PRODUIT / PRODUKTZERTIFIZIERUNG / CERTIFICACIÓN DE PRODUCTO

## CAM

(Criteri ambientali minimi)

### IT\_

Sono entrati in vigore nel 2017 in Italia i nuovi CAM “Edifici”, i criteri ambientali minimi fissati per gli appalti pubblici per progettazione e lavori per la nuova costruzione, ristrutturazione e manutenzione di edifici pubblici. Le piastrelle di ceramica Keope sono in grado di offrire un importante contributo per la conformità ai criteri ambientali ai fini dell'ottenimento di prestazioni al di sopra della media di settore. La produzione di piastrelle in gres porcellanato Keope è stata verificata in accordo ai paragrafi applicabili dell'ISO 14021:2016 “Etichette e dichiarazioni ambientali - Asserzioni ambientali auto-dichiarate (Etichettatura ambientale Tipo II)” per i seguenti aspetti ambientali: consumo e uso d'acqua, emissioni in atmosfera (particolato e fluoruri), emissioni nell'acqua e recupero dei rifiuti.

### EN\_

*The new minimum environmental criteria - CAM - “Buildings” came into force in 2017, applicable to public contracts for design and works relating to new construction, renovation and maintenance of public buildings. Keope ceramic tiles are able to make an important contribution to compliance with environmental criteria in order to achieve performance higher than the sector average. The production of Keope porcelain stoneware tiles has been assessed in accordance with the applicable paragraphs of ISO 14021:2016 “Environmental labels and declarations - Self-declared environmental claims (Type II environmental labelling)” for the following environmental aspects: water consumption and use, emissions into the atmosphere (particulate matter and fluorides), emissions into water and waste recovery.*

### FR\_

*Les nouveaux CAM pour « Constructions », à savoir les critères minimaux de protection de l'environnement applicables aux appels d'offres publics pour l'étude de projet et les travaux de réalisation de constructions neuves, de rénovation et d'entretien des bâtiments publics sont entrés en vigueur en 2017. Les carreaux de carrelage de Keope contribuent de manière importante à obtenir la conformité aux critères de protection de l'environnement, en offrant des performances au-delà de la moyenne du secteur. La production de carrelage en grès cérame Keope s'est conformée aux paragraphes applicables de l'ISO 14021:2016 « Étiquettes et déclarations environnementales auto-proclamées (Étiquetage environnemental de type II) » pour les aspects suivants de protection de l'environnement : consommation et utilisation de l'eau, émissions dans l'atmosphère (particules et fluorures), émissions dans l'eau et recyclage des déchets.*

### DE\_

*2017 sind die neuen CAM für „Gebäude“ in Kraft getreten; es handelt sich um die die Mindestumweltkriterien für öffentliche Aufträge zur Planung und zum Bau von Neubauten, Renovierungen und Instandhaltungen öffentlicher Gebäude. Keramikfliesen von Keope können einen wichtigen Beitrag zur Einhaltung von Umweltkriterien leisten, um eine überdurchschnittliche Leistung in der Branche zu erzielen. Die Herstellung von Keope Feinsteinzeugfliesen wurde in Übereinstimmung mit den anwendbaren Absätzen der Norm ISO 14021:2016 „Umweltkennzeichnungen und -deklarationen - Umweltbezogene Anbietererklärungen (Umweltkennzeichnung Typ II)“ für folgende Umweltaspekte überprüft: Wasserverbrauch und -nutzung, Emissionen in die Atmosphäre (Partikel und Fluoride), Emissionen in Wasser und Abfallverwertung.*

### ES\_

*Han entrado en vigor en 2017 los nuevos CAM “Edificios”, los criterios ambientales mínimos establecidos para la contratación pública, para el diseño y las obras de nueva construcción, reforma y mantenimiento de edificios públicos. Los azulejos de cerámica de Keope pueden contribuir de manera importante al cumplimiento de los criterios ambientales con el fin de obtener un rendimiento superior al promedio del sector. La producción de azulejos de gres porcelánico Keope se ha verificado de acuerdo con los párrafos aplicables de la ISO 14021:2016 “Etiquetas y declaraciones ambientales - Afirmaciones ambientales autodeclaradas (etiquetado ambiental tipo II)” para los siguientes aspectos ambientales: consumo y uso de agua, emisiones a la atmósfera (partículas y fluoruros), emisiones en el agua y recuperación de residuos.*



## LEED

(Leadership in Energy and Environmental Design)

### IT\_

Ceramiche Keope si propone di introdurre il sistema di certificazione indipendente LEED – Leadership in Energy and Environmental Design – i cui parametri stabiliscono precisi criteri di progettazione e realizzazione di edifici salubri, energeticamente efficienti e a impatto ambientale contenuto. La certificazione LEED si sta affermando nel mercato americano come uno dei sistemi maggiormente diffusi per la certificazione di edifici, dalla fase di progettazione fino alla gestione quotidiana. L'eccellenza ambientale richiesta da questa certificazione garantisce la salvaguardia dell'ambiente e delle risorse naturali, il miglioramento continuo delle prestazioni ambientali delle serie e dei siti produttivi di Keope e la massima attenzione per la salute dei clienti e dipendenti Keope.

### EN\_

*Ceramiche Keope proposes to introduce the independent LEED (Leadership in Energy and Environmental Design) certification system, the parameters of which establish precise planning criteria for the realization of healthy buildings, energy-efficient and with a contained environmental impact. The LEED certification is being established on the American market as one of the most diffused systems for the certification of buildings, from the planning stage to daily management. The environmental excellence required by this certification ensures the preservation of the environment and natural resources, continuous improvement of the environmental performance of the series and the production sites of Keope and the utmost attention to the health of Keope customers and employees.*

### FR\_

*Ceramiche Keope vise à introduire le système de certification indépendant LEED – Leadership in Energy and Environmental Design – dont les paramètres définissent des critères précis de conception et réalisation d'édifices sains, efficaces du point de vue énergétique et à impact environnemental réduit. La certification LEED est en plein essor sur le marché américain, s'imposant comme un des systèmes les plus répandus pour la certification d'édifices, de la phase de conception à la gestion quotidienne. L'excellence environnementale exigée par cette certification garantit la protection de l'environnement et des ressources naturelles, l'amélioration constante des performances environnementales des séries et des sites de production de Keope et la plus grande attention pour la santé des clients et salariés Keope.*

### DE\_

*Ceramiche Keope einleitet des unabhängigen Zertifizierungssystems LEED - Leadership in Energy and Environmental Design - anstrebt, dessen Parameter präzise Kriterien für die Planung und den Bau von gesunden, energieeffizienten und umweltfreundlichen Gebäuden festlegen. Die LEED-Zertifizierung etabliert sich auf dem amerikanischen Markt als eines der am weitesten verbreiteten Systeme für die Zertifizierung von Gebäuden, von der Planungsphase bis zum täglichen Management. Die für diese Zertifizierung erforderliche Umweltqualität garantiert den Schutz der Umwelt und der natürlichen Ressourcen, die kontinuierliche Verbesserung der Umweltleistung der Serien- und Produktionsstandorte von Keope und die größte Aufmerksamkeit für die Gesundheit der Kunden und Mitarbeiter von Keope.*

### ES\_

*Ceramiche Keope está introducir el sistema de certificación independiente LEED (Leadership in Energy and Environmental Design) y cuyos parámetros establecen criterios precisos de diseño y realización de edificios saludables, energéticamente eficientes y de impacto ambiental reducido. La certificación LEED se está consolidando en el mercado americano como uno de los sistemas de mayor aceptación para la certificación de edificios, desde la fase de diseño hasta la gestión cotidiana. La excelencia ambiental que exige esta certificación garantiza la protección del ambiente y los recursos naturales, la mejora continua de los resultados ambientales de la serie de productos y las plantas de producción de Keope y la máxima atención a la salud de los clientes y los empleados de Keope.*







<b>I CREDITI LEED DEI PRODOTTI KEOPE /</b> <i>LEED CREDITS OF KEOPE PRODUCTS / LES CRÉDITS LEED DES PRODUITS KEOPE /</i> <i>DIE LEED-KREDITE DER KEOPE-PRODUKTE / CRÉDITOS LEED DE LOS PRODUCTOS KEOPE</i>			
<b>ELEMENTI /</b> <i>ELEMENTS / ELEMENTE /</i> <i>ÉLÉMENTS / ELEMENTOS</i>	<b>REQUISITI /</b> <i>REQUIREMENTS / CONDITION REQUISE /</i> <i>ANFORDERUNGEN / REQUISITOS</i>	<b>PRODOTTI KEOPE /</b> <i>KEOPE PRODUCTS / PRODUITS KEOPE /</i> <i>KEOPE-PRODUKTE / PRODUCTOS DE KEOPE</i>	<b>CREDITI FORNITI /</b> <i>CREDITS THAT CAN BE</i> <i>OBTAINED / CRÉDITS POUVANT</i> <i>ÊTRE OBTENU / KREDITS, DIE</i> <i>SEIN KÖNNEN ERHALTEN /</i> <i>CREDITOS QUE PUEDEN SER</i> <i>OBTENIDO /</i>
<b>SS: SITI SOSTENIBILI /</b> <i>SS: SUSTAINABLE SITES /</i> <i>SS: AMÉNAGEMENT</i> <i>ÉCOLOGIQUE DES SITES /</i> <i>SS: NACHHALTIGE</i> <i>BAUSTELLEN /</i> <i>SS: SITIOS SOSTENIBLES</i>	<b>Riduzione dell'effetto isola di calore /</b> <i>Reduction of the heat island effect /</i> <i>Réduction de l'effet îlot de chaleur /</i> <i>Reduzierung des wärmeisolierenden Wirkung /</i> <i>Reducción del efecto isla térmica</i>	<b>SRI ≥ 0,33</b>	<b>1</b>
<b>MR: MATERIALI E RISORSE /</b> <i>MR: MATERIALS AND RESOURCES /</i> <i>MR: MATÉRIAUX ET RESSOURCES /</i> <i>MR: MATERIALIEN UND RESSOURCEN /</i> <i>MR: MATERIALES Y RECURSOS</i>	<b>Trasparenza e ottimizzazione dei materiali per l'edificio /</b> <i>Transparency and optimisation of building materials /</i> <i>Transparence et optimisation des matériaux pour l'édifice /</i> <i>Transparenz und Optimierung von Baustoffen /</i> <i>Transparencia y optimización de los materiales del edificio</i>	<b>Disponibilità di una EPD certificata /</b> <i>Availability of a certified EPD /</i> <i>Disponibilité d'une EPD certifiée /</i> <i>Verfügbarkeit einer zertifizierten EPD /</i> <i>Disponibilidad de un certificado EPD</i>	<b>1</b>
		<b>Disponibilità di una EPD multi attributo /</b> <i>Availability of a EPD multi attribute /</i> <i>Disponibilité d'une EPD multi attribut /</i> <i>Verfügbarkeit einer EPD Multi-Attribut /</i> <i>Disponibilidad de una EPD multi atributo</i>	<b>1</b>
	<b>Fonte delle materie prime /</b> <i>Source of raw materials /</i> <i>Source des matières premières /</i> <i>Rohstoffquelle /</i> <i>Origen de las materias primas</i>	<b>Criteri di estrazione responsabile /</b> <i>Responsible extraction criteria /</i> <i>Critères d'extraction responsable /</i> <i>Kriterien für einen verantwortungsvollen Abbau /</i> <i>Criterios de extracción responsable</i>	<b>1</b>
		<b>Contenuto di materiale riciclato /</b> <i>Recycled Content /</i> <i>Teneur en matériau recyclé /</i> <i>Gehalt an Recyclingmaterial /</i> <i>Contenido de material reciclado</i>	<b>max 1</b>
<b>Ingredienti dei materiali /</b> <i>Material ingredients /</i> <i>Ingrédients des matériaux /</i> <i>Inhaltsstoffe der Materialien /</i> <i>Ingredientes de los materiales</i>	<b>Disponibilità di una HPD /</b> <i>Availability of a HPD /</i> <i>Disponibilité d'une HPD /</i> <i>Verfügbarkeit einer HPD /</i> <i>Disponibilidad de un HPD</i>	<b>1</b>	
	<b>Mappatura degli ingredienti ai sensi della normativa REACH /</b> <i>Mapping of ingredients in compliance with the REACH standard /</i> <i>Représentation cartographique des ingrédients selon les normes REACH /</i> <i>Inhaltsstoffabbildung gemäß den REACH-Vorschriften /</i> <i>Catalogación de los ingredientes con arreglo a la normativa REACH</i>	<b>1</b>	
<b>IEQ (QUALITÀ AMB. INTERNA) /</b> <i>IEQ (INDOOR ENV. QUALITY) /</i> <i>IEQ (QUALITÉ ENV. DE L'AIR INTÉRIEUR) /</i> <i>IEQ (QUALITÄT DES INNENRAUMKLIMAS) /</i> <i>IEQ (CALIDAD AMB. INTERIOR)</i>	<b>Materiale basso emissivi /</b> <i>Low emission materials /</i> <i>Matériaux faible émissivité /</i> <i>Emissionsarme Materialien /</i> <i>Materiales de bajas emisiones</i>	<b>Assenza di Composti Organici Volatili (VOC) /</b> <i>No Volatile Organic Compounds (VOC) /</i> <i>Absence de Composés Organiques Volatiles (VOC) /</i> <i>Keine flüchtigen organischen Verbindungen (VOCs) /</i> <i>Ausencia de compuestos orgánicos volátiles (COV)</i>	<b>1</b>
<b>CREDITI LEED TOTALI FORNITI /</b> <i>TOTAL LEED CREDITS OBTAINED / TOTAL CRÉDITS LEED FOURNIS /</i> <i>PRODUKTEN ENTSTEHENDE LEED-KREDITE TOTALEN /</i> <i>CRÉDITOS LEED TOTAL</i>			<b>8</b>

\* [Certificazioni disponibili su keope.com](#) / [Certifications available on keope.com](#) / [Certifications disponibles sur keope.com](#) / [Zertifizierungen verfügbar unter keope.com](#) / [Certificaciones disponibles en keope.com](#)

[Certificazioni disponibili su keope.com](#) / [Certifications available on keope.com](#) / [Certifications disponibles sur keope.com](#) / [Zertifizierungen verfügbar unter keope.com](#) / [Certificaciones disponibles en keope.com](#)

368/369

<b>LEED</b> <b>Leadership in energy and environmental Design Recycled material content Keope product</b>		
<b>COLLEZIONE</b> <i>COLLECTIONS / COLLECTIONS /</i> <i>KOLLEKTIONEN / COLECCIONES</i>	<b>COLORE</b> <i>COLOURS / COULEURS /</i> <i>FARBE / COLORES</i>	<b>%MATERIALE DI SCARTO PRE-CONSUMER</b> <i>%PRE-CONSUMER WASTE MATERIAL /</i> <i>% DÉCHETS AVANT-CONSOMMATION /</i> <i>% VORVERBRAUCHER-ABFALLMATERIAL /</i> <i>% DE MATERIAL DE DESECHO PRE-CONSUMO</i>
<b>Aran</b>	ARAN ANTHRACITE	≥ 20
<b>Back</b>	BACK ANTHRACITE	≥ 20
<b>Back</b>	BACK GREY	≥ 20
<b>Beat</b>	BEAT TAUPE	≥ 20
<b>Chorus</b>	CHORUS TOBACCO	≥ 20
<b>Elements Design</b>	ELEMENTS DESIGN BLACK	≥ 20
<b>Elements Design</b>	ELEMENTS DESIGN GREY	≥ 20
<b>Elements Lux</b>	ELEMENTS LUX EMPERADOR	≥ 20
<b>Elements Lux</b>	ELEMENTS LUX PORT LAURENT	≥ 20
<b>Granigliati</b>	BARDIGLIO	≥ 10
<b>Ikon</b>	IKON GREY	≥ 20
<b>Limes</b>	QUARTZ MULTICOLOR	≥ 20
<b>Limes</b>	PORFIDO COLD	≥ 20
<b>Limes</b>	PORFIDO WARM	≥ 20
<b>Midlake</b>	ARDESIA	≥ 20
<b>Midlake</b>	PORFIDO	≥ 20
<b>Midlake</b>	QUARTZGREY	≥ 20
<b>Moov</b>	MOOV ANTHRACITE	≥ 20
<b>Moov</b>	MOOV MOKA	≥ 20
<b>Percorsi Extra</b>	PIETRA DI COMBE	≥ 10
<b>Percorsi Extra</b>	PIETRA DI FAEDIS	≥ 10
<b>Percorsi Quartz</b>	PERCORSI QUARTZ BLACK	≥ 10
<b>Percorsi Smart</b>	PIETRA DI LAVIS	≥ 20
<b>Sight</b>	SIGHT ANTHRACITE	≥ 20
<b>Soul</b>	SOUL GREY	≥ 20
<b>Soul</b>	SOUL WALNUT	≥ 20
<b>Ubik</b>	UBIK ANTHRACITE	≥ 20
<b>Code - Keope Contract</b>	CODE ANTHRACITE	≥ 20
<b>Dunstone - Keope Contract</b>	DUNSTONE BEIGE	≥ 20
<b>Dunstone - Keope Contract</b>	DUNSTONE GREY	≥ 20
<b>Extreme - Keope Contract</b>	EXTREME ANTHRACITE	≥ 20
<b>Londale - Keope Contract</b>	LONDALE SILVER	≥ 20
<b>Londale - Keope Contract</b>	LONDALE GREY	≥ 20
<b>Swisstone - Keope Contract</b>	SWISSTONE ANTHRACITE	≥ 20
<b>Swisstone - Keope Contract</b>	SWISSTONE GREY	≥ 20
<b>Swisstone - Keope Contract</b>	SWISSTONE TAUPE	≥ 20
<b>Urban - Keope Contract</b>	URBAN ANTHRACITE	≥ 20
<b>Urban - Keope Contract</b>	URBAN GREY	≥ 20

[Certificazione disponibile su keope.com](#) / [Certification available on keope.com](#) / [Certification disponible sur keope.com](#) / [Zertifizierung verfügbar unter keope.com](#) / [Certificación disponible en keope.com](#)

# POSA E MANUTENZIONE/ LAYING AND MAINTENANCE

POSE ET D'ENTRETIEN / VERLEGUNG UND PFLEGE / COLOCACIÒN Y MANTENIMIENTO

**IT\_**  
GRES FINE PORCELLANATO KEOPE:  
**descrizioni di capitolato**

**1) Caratteristiche merceologiche e di processo**  
Le piastrelle ed i pezzi speciali in gres fine porcellanato KEOPE sono ottenute da materie prime di elevata qualità, argille pregiate con l'aggiunta di feldspati e caolini, che vengono atomizzate e pressate a secco alla pressione specifica di 450 Kg/cm2 quindi cotte in cicli termici alla temperatura di 1250 °C. Il materiale risulta costituito da un impasto unico, compatto, ingelivo, inassorbente e resistente agli attacchi chimici e fisici.

**2) Conformità alle norme**  
Normativa di riferimento : **UNI EN 14411 e ISO 13006** (vedi tabella caratteristiche tecniche)

La conformità alla norma ed il mantenimento di tali caratteristiche è garantito dal Sistema di Gestione della Qualità attivato da Ceramiche Keope e certificato secondo la norma UNI EN ISO 9001.

**FR\_**  
GRES CERAME FIN KEOPE :  
**cahier des charges**

**1) Caractéristiques du produit et du procédé de fabrication**  
*Les carreaux et les pièces spéciales en grès cérame fin KEOPE sont fabriqués à partir de matières premières exceptionnelles, argiles de grande qualité avec ajout de feldspaths et kaolins, atomisées et pressées à sec à 450 kg/cm2. Elles sont ensuite cuites en cycles thermiques à 1 250°C. Le matériau est ainsi constitué d'une pâte unique, compacte, ingélive, imperméable et résistante aux agents chimiques et physiques.*

**2) Conformité aux normes**  
Réglementation de référence : **UNI EN 14411 ET ISO 13006** (voir tableau caractéristiques techniques)

La conformità alla norma ed il mantenimento di tali caratteristiche è garantito dal Sistema di Gestione della Qualità attivato da Ceramiche Keope e certificato secondo la norma UNI EN ISO 9001.

**EN\_**  
KEOPE FINE PORCELAIN STONEWARE:  
**specifications**

**1) Product and process features**  
*KEOPE tiles and special trims in fine porcelain stoneware are made from prime quality raw materials, exclusive clays with the addition of feldspars and kaolins, which are atomised and dry-pressed at a specific pressure of 450 Kg/cm2. They are then fired in heat cycles at 1250 °C. The result is a single body, consistent, frost-proof, impervious material that is resistant to chemical and physical agents.*

**2) Compliance with standards**  
*Reference standard: **UNI EN 14411 AND ISO 13006** (see technical characteristics table)*

*Compliance with the standard and the preservation of the specified characteristics are guaranteed by the Quality Management System implemented by Ceramiche Keope and certified in accordance with UNI EN ISO 9001 standards.*

**1) Produkt- und Prozesseigenschaften**  
*Die Fliesen und Formteile aus Feinsteinzeug von KEOPE werden aus Rohstoffen sehr hoher Qualität hergestellt, hochwertige Tone mit Zusatz von Feldspaten und Kaolinen, die sprühgetrocknet und mit einem spezifischen Druck von 450 Kg/cm2 trockengepresst und daraufhin in Wärmezyklen bei einer Temperatur von 1250° C gebrannt werden. Das Material besteht aus einer einheitlichen Masse und ist kompakt, frostbeständig, wasserabweisend sowie beständig gegen chemische und physikalische Einwirkungen.*

**2) Konformität mit den Normen**  
*Referenznorm: **UNI EN 14411 - ISO 13006** (siehe Tabelle "Technische Daten")*

*Die Konformität mit der Norm und die Erhaltung dieser Eigenschaften wird vom Qualitätsmanagementsystem von Ceramiche Keope garantiert und nach UNI EN ISO 9001 zertifiziert.*

**ES\_**  
GRES FINO PORCELÁNICO KEOPE:  
**especificaciones**

**1)Características del producto y el proceso**  
*Las baldosas, los azulejos y las piezas especiales de gres fino porcelánico KEOPE se obtienen a partir de materias primas excelentes, arcillas de gran calidad con adición de feldespatos y caolines, que son atomizadas y prensadas en seco a una presión específica de 450 Kg/cm2, siendo luego cocidas en ciclos térmicos a una temperatura de 1250°C. El material queda constituido por una pasta única, compacta, resistente a la helada, impermeable y resistente a los agentes químicos y físicos.*

**2) Cumplimiento de las normas**  
*Normativa de referencia: **UNI EN 14411 Y ISO 13006** (véase tabla de características técnicas)*

*El cumplimiento de la norma y el mantenimiento de dichas características están garantizados por el Sistema de Gestión de la Calidad implementado por Ceramiche Keope y certificado de acuerdo con la norma UNI EN ISO 9001.*

**IT\_**  
**POSA IN OPERA**

Al ricevimento del materiale, dopo aver controllato la corrispondenza tra i documenti di consegna e la merce e comunque prima della posa in opera, è importante verificare accuratamente che il tono, il calibro e la scelta del materiale siano conformi. È inoltre necessario verificare che il materiale sia esente da vizi palesi (così come definiti dalle condizioni generali di vendita e dalla tabella 2 del presente manuale) poiché non potranno essere accettati reclami su materiale già posato i cui difetti fossero visibili prima della installazione. Premesso che la stonalizzazione è una caratteristica propria dei prodotti ceramici si richiede la verifica del valore V-shade delle piastrelle che si dovranno installare. Per ottenere comunque il miglior risultato estetico possibile, posare il materiale attingendo i pezzi da più scatole, in modo da ottenere una miscelazione ottimale. Per prodotti venati, come per le pietre naturali, si raccomanda di disporre la venatura delle lastre in modo da ottenere il migliore effetto estetico e cromatico. Il committente finale dovrà assicurare, per quanto di sua pertinenza, condizioni microclimatiche e di illuminazione tali da assicurare la possibilità per il posatore di condurre le operazioni di installazione in modo affidabile, controllando pertanto i materiali e l'opera in corso di realizzazione, come prescritto in precedenza.

**FR\_**  
**POSE**  
*Au moment de la réception du matériau, après avoir contrôlé la correspondance entre les documents de livraison et la marchandise et dans tous les cas avant la pose, il est important de vérifier avec minutie que le ton, le calibre et le choix du matériau sont conformes. En outre, il est nécessaire de vérifier que le matériau est exempt de vices apparents (définis par les conditions générales de vente et par le tableau 2 du présent manuel) dans la mesure où aucune réclamation concernant un matériau déjà posé, dont les vices étaient visibles avant l'installation, ne pourra être acceptée. En partant du principe que le dénuançage est une caractéristique propre aux produits céramiques, il est demandé de vérifier la valeur V-SHADE des carreaux qui devront être installés. Afin d'obtenir le meilleur résultat esthétique possible, il faut poser le matériau en prenant des carreaux provenant de boîtes différentes de manière à obtenir un mélange parfait. Pour les produits à veinures, comme les pierres naturelles, il est recommandé de disposer la veinure des plaques de manière à obtenir le plus bel effet esthétique et chromatique. Le client final devra garantir, dans la mesure du possible, des conditions microclimatiques et d'éclairage permettant au poseur de conduire les opérations d'installation de manière fiable, en contrôlant, par conséquent, les matériaux et l'ouvrage en cours de réalisation, comme indiqué précédemment.*

**EN\_**  
**LAYING**

*When you receive the material ordered, after having checked that the goods delivered correspond to the shipping documents, and in any case before laying, it is important to check carefully that the tone, gauge and grade of material match your order. It is also necessary to check that the material presents no visible defects (as defined by the general terms of sale and by table 2 of this manual), as no complaints will be accepted once the material has been laid, if such defects were visible beforehand. As the shading is a characteristic of ceramic products, we request that you check the value V- SHADE of the tiles you wish to fit. To obtain the best aesthetic result possible, the material should be laid using tiles from different boxes and thus obtain a varied mixture. For products with vein markings, as with natural stone effect tiles, we recommend arranging the vein markings of the slabs in such a way that the best aesthetic and chromatic effect is obtained.*

*The end customer must assure that the environmental and lighting conditions for which he is responsible are suitable to allow the tile fitter to carry out his work in a reliable manner. He must therefore check the materials and the tile-laying operation, as described above.*

**DE\_**  
**VERLEGUNG VOR ORT**  
*Nach Erhalt des Materials und nach Prüfung der Übereinstimmung der Lieferpapiere mit der Ware, auf jeden Fall aber vor der Verlegung, muss sorgfältig geprüft werden, ob Farbton und Werkmaß übereinstimmen und es sich um das bestellte Material (Sortierung) handelt. Es muss auch überprüft werden, dass das Material frei von offensichtlichen Mängeln ist (wie in den allgemeinen Geschäftsbedingungen und in Tabelle 2 dieses Handbuchs definiert), da keine Ansprüche auf bereits verlegtes Material geltend gemacht werden können, dessen Mängel vor der Verlegung bereits sichtbar waren. Da Farbabweichungen ein Merkmal von keramischen Produkten sind, ist eine Überprüfung des V- SHADE-Wertes der zu verlegenden Fliesen erforderlich. Um das bestmögliche ästhetische Ergebnis zu erzielen, verlegen Sie das Material am besten so, dass Fliesen abwechselnd aus mehreren Kästen entnommen werden, um eine optimale Durchmischung zu erzielen. Bei Produkten mit Äderungen wird, wie bei Naturstein, empfohlen die Äderungen der Platten so anzuordnen, dass die beste ästhetische und farbliche Wirkung erzielt wird. Der Auftraggeber hat, soweit möglich, für die mikroklimatischen Bedingungen und die entsprechenden Lichtverhältnisse zu sorgen, die es dem Fliesenleger ermöglichen, die Verlegearbeiten zuverlässig durchzuführen und dabei die Materialien und die laufenden Arbeiten, wie zuvor vorgeschrieben, zu kontrollieren.*

**ES\_**  
**COLOCACIÓN**

*Al recibir el material, después de controlar que la mercancía corresponda con los documentos de entrega (albarán), y siempre antes de colocarlo, es importante comprobar minuciosamente que el tono, el calibre y la elección del material sean conformes. También es necesario comprobar que el material no tenga vicios evidentes (definidos en las condiciones generales de venta y en la tabla 2 de este manual) ya que no podrán aceptarse reclamaciones sobre el material ya colocado cuyos defectos hayan sido visibles antes de la instalación. Dado que la destonalización es una característica de los productos cerámicos, es necesario comprobar el valor V-SHADE de las cerámicas que se deberán colocar. Para obtener el mejor resultado estético posible, coloque el material alternando las piezas de varias cajas para obtener una composición ideal.Para los productos veteados, al igual que para las piedras naturales, se recomienda distribuir el veteado de las placas de manera de obtener el mejor efecto estético y cromatico. El cliente final deberá garantizar, dentro de su competencia, condiciones microclimáticas y de iluminación que aseguren que el colocador tenga la posibilidad de realizar las operaciones de colocación de manera fiable, controlando los materiales y el trabajo que está realizando, de acuerdo con lo prescrito anteriormente.*

## IT\_

Si consiglia di posare a colla con l'utilizzo di collanti specifici ad elevate prestazioni. Si ricorda che, al momento della posa, il sottofondo deve essere stabile, asciutto e maturo. Comunque è necessario seguire le istruzioni dei produttori dei materiali per sottofondi e collanti specifici utilizzati. Gli adesivi cementizi devono essere applicati a temperatura ambiente, ed in genere compresa tra +5° C e +30/35° C. I collanti più adatti alla posa dei materiali a marchio Ceramiche Keope, si possono identificare sulla base della Normativa Europea attualmente in vigore EN12004. Durante la posa è necessario non segnare il materiale sulla superficie di utilizzo con matite (grafite) o pennarelli indelebili, in particolar modo sui prodotti levigati. Pur non essendo necessario bagnare le piastrelle prima della posa, nel caso il retro della piastrella si presenti molto polveroso è comunque consigliabile un rapido lavaggio in acqua pulita. Nel periodo compreso tra la conclusione della posa e la consegna al committente finale, la piastrellatura ceramica dovrà essere mantenuta pulita e libera da cemento, sabbia, malta e da qualsiasi altro materiale che possa causare macchie e/o fenomeni di abrasione meccanica superficiale.

È necessario proteggere la posa da danni o contaminazioni potenzialmente apportate a seguito di una prevedibile frequentazione di altri operatori quali imbianchini, elettricisti, falegnami etc. Per la posa "a correre" si raccomanda di sfalsare le piastrelle al massimo di 20 cm. Per i materiali rettificati la fuga minima prescritta è di 2 mm (questo tipo di posa consente una maggior presa del fugante sui fianchi delle lastre, un maggior assorbimento di eventuali movimenti del sottofondo ed una compensazione delle lastre). Per quelli non rettificati si prescrive una fuga di almeno 5 mm. Ceramiche Keope non accetta contestazioni per posa di materiale rettificato con fughe inferiori ai 2mm.I prodotti in gres porcellanato Ceramiche Keope, pur essendo materiali molto resistenti, possono essere sagomati (per realizzazioni di top, scale ...), perforati per l'installazione di impianti tecnico-sanitari, utilizzando appositi dischi diamantati ed attrezzature idonee.

##### AVVERTENZA:

Ceramiche Keope a materiale già posato:

- non accetta contestazioni dovuti a vizi palesi, così come definiti nella tabella 2 del presente manuale.
- non risponde sulla qualita' dell'opera piastrellata ma solamente sulle caratteristiche del materiale fornito.

È bene conservare al termine della posa, alcune piastrelle di scorta per eventuali riparazioni o anche per disporre di un campione rappresentativo del materiale in caso di contestazione.

## EN\_

*We recommend that the tiles are glued to the substrate using specific, high-performance adhesives. Please remember that the substrate must be stable, dry and properly prepared for laying. It is necessary in any case to follow the instructions provided by the manufacturers of substrates and the specific adhesives used. Cement-based adhesives must be applied at room temperature, generallyly between +5° and 30/35° C. The most suitable adhesives for the laying of Ceramiche Keope materials should be labelled according to the currently valid European Standard, EN12004. When laying the material, no marks should be made on the surface with pencils (graphite) or permanent markers, particularly on polished surfaces. Although it is not necessary to dampen the tiles before laying, if the tiles are very dusty, it is advisable to rinse quickly in clean water. In the period after the surfaces have been tiled until they are handed over the end customer, the ceramic tiles must be kept clean and free of cement, sand, mortar and any other material that might cause stains and/or mechanical surface abrasion.*

*The finished surfaces must be protected from potential damage or contaminations owing to the foreseeable presence of other tradesman such as painters and decorators, electricians, carpenters etc. For continuous surfaces we recommend staggered layouts, with a distance between edges of no more than 20 cm. For rectified materials, the minimum joint prescribed is 2 mm (this method allows the grout to have a better grip on the sides of the slabs, greater absorption of any movements of the substrate and consequently of the slabs themselves). For non-rectified materials the minimum joint prescribed is 5 mm. Ceramiche Keope will not accept any complaints for rectified tiles that have been laid leaving joints of less than 2 mm. Although products in Ceramiche Keope porcelain stoneware are highly resistant materials, they can be shaped (to create worktops, stairs, ...) and drilled to fit around pipes and other fittings etc, using purpose-built diamond abrasive discs and other suitable equipment.*

##### WARNING:

*For material that has already been laid, Ceramiche Keope:*

- does not accept any complaints for visible defects, as defined in table 2 of this manual*
- does not accept liability for the quality of the tiled surface but only for the characteristics of the material supplied.*

*Once the material has been laid, it is wise to keep aside a few tiles for possible future repairs or to have a sample of the material in the event of complaints.*

## FR\_

*Il est conseillé de poser avec de la colle en utilisant des adhésifs spécifiques à hautes prestations. Il est rappelé que, au moment de la pose, la sous-couche doit être stable, sèche et adaptée. Il est dans tous les cas nécessaire de suivre les instructions des fabricants des matériaux pour les sous-couches et les adhésifs cimentaires spécifiques utilisés. Les adhésifs cimentaires doivent être appliqués à une température ambiante, généralement entre +5° C et + 30/35° C. Les adhésifs les plus adaptés à la pose des matériaux de la marque Ceramiche Keope peuvent être identifiés à partir de la Norme Européenne actuellement en vigueur EN12004. Durant la pose, il est nécessaire de ne pas écrire sur la surface d'utilisation du matériau à l'aide de crayons (graphites) ou de marqueurs indélébiles, notamment sur celle des produits polis. Bien qu'il ne soit pas nécessaire de mouiller les carreaux avant la pose, il est toutefois conseillé de laver rapidement avec de l'eau propre le dos du carreau si celui-ci est poussiéreux. Dans la période comprise entre la conclusion de la pose et la livraison au client final, le carrelage céramique devra être maintenu propre et dépourvu de ciment, sable, mortier et de tout autre matériau pouvant entraîner des taches et/ou des phénomènes d'abrasion mécanique superficielle.*

*Il est nécessaire de protéger la pose vis-à-vis des dommages ou des contaminations provenant, éventuellement, d'un passage prévisible d'autres ouvriers tels que des peintres en bâtiment, des électriciens, des menuisiers, etc. Pour la pose dite à fond perdu, il est recommandé de décaler les carreaux de 20 cm au maximum. Pour les matériaux rectifiés, le joint minimum prescrit est de 2 mm (ce type de pose permet une plus grande prise du jointoyant sur les bords des carreaux, une plus grande absorption des éventuels mouvements de la sous-couche et une compensation des carreaux). Pour les carreaux non rectifiés, il faut réaliser un joint d'au moins 5 mm. Ceramiche Keope n'accepte pas les contestations relatives à la pose de matériau rectifié avec des joints inférieurs à 2 mm. Les produits en grès cérame Ceramiche Keope, bien qu'étant des matériaux très résistants, peuvent être façonnés (pour la conception de plans et d'escaliers) et perforés pour la mise en place d'installations technico-sanitaires en utilisant des disques diamantés spécifiques et des équipements adaptés.*

##### AVERTISSEMENT :

*Ceramiche Keope, concernant le matériau déjà posé,*

- n'accepte pas les contestations dues à des vices apparents, définis dans le tableau 2 du présent manuel.*
- n'est pas responsable de la qualité du carrelage réalisé, mais uniquement des caractéristiques du matériau fourni.*

*Il est conseillé de conserver, au terme de la pose, plusieurs carreaux à mettre de côté en vue de réparations éventuelles ou afin de disposer aussi d'un échantillon représentatif du matériau en cas de contestation.*

## DE\_

*Es wird empfohlen, spezielle, leistungsstarke Klebstoffe aufzutragen. Denken Sie daran, dass der Untergrund zum Zeitpunkt der Verlegung stabil, trocken und ausgereift sein muss. In jedem Fall müssen die jeweiligen Anweisungen der Hersteller der jeweiligen Untergründe und spezifischen Klebstoffe befolgt werden. Verlegemörtel auf Zementbasis müssen bei Raumtemperatur und in der Regel zwischen +5° C und +30/35° C aufgetragen werden. Informationen über die am besten geeigneten Klebstoffe für die Verlegung von Fliesen und Platten der Marke Ceramiche Keope sind der derzeit gültigen europäischen Norm EN12004 zu entnehmen. Während der Verlegung darf das Material nicht auf der Oberseite mit Bleistiften (Graphit) oder Permanentmarkern gekennzeichnet werden, insbesondere gilt dies für polierte Fliesen und Platten. Obwohl ein Anfeuchten der Fliesen vor dem Verlegen nicht erforderlich ist, ist es ratsam, wenn die Rückseite der Fliesen sehr staubig ist, sie schnell in sauberem Wasser abzuwaschen. Während des Zeitraums zwischen Abschluss der Verlegung und der Übergabe an den Auftraggeber müssen die Keramikfliesen sauber und frei von Zement, Sand, Mörtel und jeglichem anderen Material, das Flecken und/oder mechanischen Oberflächenabrieb verursachen kann, gehalten werden.*

*Die verlegten Flächen müssen vor Beschädigungen oder Verunreinigungen geschützt werden, die möglicherweise durch eine vorhersehbare Anwesenheit anderer Handwerker wie Maler, Elektriker, Zimmerleute usw. verursacht werden. Für die Verbandverlegung empfiehlt es sich, die Fliesen maximal um 20 cm zu versetzen. Für geschliffene Fliesen und Platten wird eine Fugenbreite von mindestens 2 mm vorgeschrieben (diese Art der Verlegung ermöglicht eine bessere Haftung des Fugenmörtels an den Seiten der Platten, eine bessere Aufnahme von Bewegungen des Untergrundes und eine Kompensation der Platten). Für nicht geschliffene Fliesen und Platten wird eine Fugenbreite von mindestens 5 mm vorgeschrieben. Ceramiche Keope akzeptiert keine Reklamationen, wenn geschliffene Fliesen und Platten mit einer Fugenbreite von weniger als 2 mm verlegt werden. Fliesen und Platten aus Feinsteinzeug von Ceramiche Keope können, obwohl es sich um sehr belastbare Ware handelt, auch zugeschnitten (für Arbeitsplatten, Treppen...) und für die Installation von technischen und sanitären Anlagen mit Bohrungen versehen werden, dazu müssen spezielle Diamantscheiben und geeignete Geräte verwendet werden.*

##### HINWEIS:

*Ceramiche Keope auf schon verlegten fliesen und platten:*

- Ceramiche Keope akzeptiert keine beanstandungen aufgrund offensichtlicher mängel, wie in tabelle 2 dieses handbuchs definiert.*
- Ceramiche Keope ist nicht für die qualität der fliesenarbeiten verantwortlich, sondern nur für die eigenschaften des gelieferten materials.*

*Es ist ratsam, einige ersatzfliesen am ende der installation für eventuelle reparaturen aufzubewahren oder im falle einer reklamation auf diese weise ein repräsentatives muster des materials zur hand zu haben.*

## ES\_

*Se recomienda colocar la cerámica utilizando adhesivos específicos de altas prestaciones. Se recuerda que en el momento de la colocación, la subcapa debe ser estable, estar seca y curada. De todas maneras, siga las instrucciones de los fabricantes de los materiales para subcapas y adhesivos específicos utilizados. Los adhesivos cementosos se deben aplicar a temperatura ambiente, por lo general, entre +5 °C y +30/35 °C. Los adhesivos más adecuados para la colocación de los materiales marca Ceramiche Keope se pueden identificar sobre la base de la Normativa Europea EN 12004 vigente actualmente. Durante la colocación, no marque el material sobre la superficie de uso con lápices (grafito) ni marcadores indelebles, principalmente las cerámicas pulidas. Aunque no sea necesario mojar la cerámica antes de colocarla, si el reverso de la baldosa estuviera muy polvoriento, se recomienda lavarla rápidamente con agua limpia. Durante el período comprendido entre la conclusión de la colocación y la entrega al cliente final, el revestimiento cerámico deberá mantenerse limpio y libre de cemento, arena, mortero y de cualquier otro material que pueda causar manchas y/o fenómenos de abrasión mecánica superficial.*

*Es necesario proteger la colocación de daños o contaminaciones potencialmente causadas por el tráfico frecuente de otros operadores, tales como pintores, electricistas, carpinteros, etc. Para la colocación con junta corrida se recomienda desplazar las baldosas hasta un máximo de 20 cm. Para los materiales rectificados, la junta mínima obligatoria es de 2 mm (este tipo de colocación permite un mayor agarre del producto de rejuntado a los bordes de las placas, una mayor absorción de los posibles movimientos de la subcapa y una compensación de las placas). Para las cerámicas no rectificadas, la junta debe ser de al menos 5 mm. Ceramiche Keope no acepta reclamaciones para colocación de material rectificado con juntas inferiores a 2 mm. Los productos de gres porcelánico, aunque sean materiales muy resistentes, pueden ser conformados (para la realización de encimeras, escaleras, etc.), perforados para la instalación de sistemas técnicos y sanitarios, utilizando discos diamantados especiales y herramientas adecuadas.*

##### ADVERTENCIA:

*Ceramiche Keope con el material ya colocado:*

- no acepta reclamaciones debidas a vicios evidentes, así como definidos en la tabla 2 de e ste manual.*
- no responde sobre la calidad de la obra sino que responde únicamente de las características del material suministrado.*

*Se recomienda conservar después de la colocación algunas cerámicas de repuesto para posibles reparaciones o incluso para tener una muestra representativa del material en caso de reclamación.*

## IT\_ GIUNTI E STUCCATURE

Negli ambienti di grande dimensione è assolutamente necessario posizionare dei giunti di dilatazione con regolarità; mentre, per i piccoli ambienti è sufficiente lasciare un leggero stacco fra piastrellato e muri perimetrali, che verrà coperto dal battiscopa. In ogni caso è necessaria la supervisione del progettista o del direttore di cantiere che verifichi che l'installazione rispetti le normative vigenti nei singoli paesi. Per l'utilizzo di stucchi epossidici o con aggiunte di resine o similari, si consiglia di seguire con attenzione le indicazioni dei produttori perché il loro rapido indurimento richiede maggiori attenzioni. Riteniamo inoltre sia importante fare una prova preventiva di pulizia su una porzione di pavimento. In modo particolare per i prodotti lappati e levigati suggeriamo l'utilizzo di stucchi in cadenza di colore con la piastrella (es. evitare piastrella bianca con stucco nero). Dopo la stuccatura delle piastrelle è importante, a stucco ancora fresco, rimuovere immediatamente in modo accurato con spugna ed abbondante acqua lo stucco in eccesso. È comunque indispensabile alcuni giorni dopo la posa, a fughe asciutte, effettuare la pulizia di fondo mediante l'utilizzo di acidi tamponati (si veda il capitolo seguente: **Pulizia “dopo posa”**) al fine di rimuovere completamente tutti i residui di cantiere. Alcuni esempi di detergenti a base “acida” specifici per la pulizia dopo posa sono:

- DETERDEK PRO FILA INDUSTRIA CHIMICA** www.filachim.com
- DELTA PLUS KERAKOLL** www.kerakoll.com
- KERANET MAPEI** www.mapei.it
- SERVICE ACIDO GEAL** www.geal-chim.it
- DISYCOTT FABER** www.faberchimica.com
- BONACLEAN BONASYSTEM** www.bonasytemsitalia.it

### PULIZIA “DOPO POSA”

**Gres porcellanato**

La pulizia “dopo posa” è obbligatoria a fine cantiere. La rimozione inadeguata o tardiva dei residui della stuccatura utilizzata per le fughe può lasciare alonature difficili da rimuovere e creare sulla pavimentazione un film cementizio capace di assorbire ogni forma di sporco. È indispensabile sciogliere ed eliminare completamente questi residui con l'utilizzo di acidi tamponati diluiti in acqua (attenersi sempre alle istruzioni d’uso sulle confezioni dei prodotti utilizzati), che dovranno essere totalmente rimossi successivamente in breve tempo con abbondante risciacquo di tutto il pavimento. Si consiglia di ripetere l’operazione di lavaggio e risciacquo fino alla completa rimozione di ogni alone o residuo. Sugeriamo di eseguire un lavaggio preliminare su una superficie campione di alcuni metri quadrati; in caso di esito positivo, si estenderà la pulizia su tutta la superficie. Una volta effettuato il lavaggio sopracitato, è necessario eseguire un lavaggio basico o alcalino utilizzando detersivi sgrassanti. Questo perché il lavaggio acido può lasciare untuosità sul pavimento che potrebbe contribuire a trattenere lo sporco.

## EN\_ JOINTS AND GROUTING

*In large, open spaces it is absolutely essential to position the expansion joints at regular intervals; in smaller rooms, on the other hand, it is sufficient to leave a slight space between the tiled surface and the walls around the room, which will be hidden by the skirting board. The tiles must be laid under the supervision of a planner or site manager, who must ensure that the work is carried out in accordance with the standards in force in the respective country. For the use of epoxy grouting or the addition of resins or similar substances, it is important to properly follow the manufacturer’s instructions as the fact such products harden more quickly requires greater attention. We also believe it is important to carry out a cleaning test on a part of the flooring. Especially for lapped and polished products, we suggest using grouts that match the colour of the tiles (e.g. avoid using black grout with white tiles).It is important to remove any excess grouting immediately and accurately after application while still fresh, using a sponge and plenty of water. A few days after laying, once the joints are completely dry, it is essential to thoroughly clean the tiled surface using buffered acids (see the following chapter: Cleaning “after laying”), in order to completely remove all residual substances. Some examples of “acid”-based detergents designed specifically for this purpose are:*

- DETERDEK PRO FILA INDUSTRIA CHIMICA** www.filachim.com
- DELTA PLUS KERAKOLL** www.kerakoll.com
- KERANET MAPEI** www.mapei.it
- SERVICE ACIDO GEAL** www.geal-chim.it
- DISYCOTT FABER** www.faberchimica.com
- BONACLEAN BONASYSTEM** www.bonasytemsitalia.it

### CLEANING “AFTER LAYING”

**Porcelain stoneware**

*Properly cleaning the tiles after they have been laid is crucial. If residues of the grouting used is removed inaccurately or too late, it may leave stains that are difficult to remove, and create a film of cement on the floor that can absorb any form of dirt. It is essential to loosen and eliminate these residues completely using buffered acids diluted in water (always follow the instructions provided on the box), which will then have to be removed quickly by rinsing the entire floor with plenty of clean water. We advise repeating this washing and rinsing operation several times until any stains or residues are completely removed. We suggest carrying out a preliminary test on a sample surface of several metres; if the results are good, you can then clean the entire surface. After this, the floor must then be cleaned thoroughly with a basic or alkaline detergent to degrease the surface. This is because acidic detergents may leave a film of grease on the floor that could trap dirt.*

## FR\_ JOINTS ET JOINTOIEMENTS

Scrittura in francese: "La pose des joints des carreaux doit être réalisée avec un produit adapté, et il est recommandé de vérifier la pose des joints des carreaux avec un produit adapté".

- DETERDEK PRO FILA INDUSTRIA CHIMICA** www.filachim.com
- DELTA PLUS KERAKOLL** www.kerakoll.com
- KERANET MAPEI** www.mapei.it
- SERVICE ACIDO GEAL** www.geal-chim.it
- DISYCOTT FABER** www.faberchimica.com
- BONACLEAN BONASYSTEM** www.bonasytemsitalia.it

### NETTOYAGE “APRÈS LA POSE”

**Grès cérame**

*Le nettoyage « après la pose » est obligatoire à la fin des travaux. Le retrait inadapté ou tardif des résidus du jointoiment utilisé pour les joints peut laisser des auréoles difficiles à enlever et créer sur le sol un film cimentaire capable d’absorber les saletés en tout genre. Il est indispensable de détacher et d’éliminer complètement ces résidus à l’aide d’acides tamponnés dilués dans l’eau (toujours se conformer aux instructions d’utilisation sur les emballages des produits utilisés) qui devront ensuite être éliminés complètement et rapidement lors du rinçage abondant de l’ensemble du sol. Il est conseillé de répéter l’opération de lavage et de rinçage jusqu’à l’élimination complète de toutes les auréoles ou de tous les résidus. Il est suggéré d’effectuer un lavage préliminaire sur une surface échantillon de plusieurs mètres carrés. Dans le cas d’un résultat positif, le nettoyage pourra être étendu sur l’ensemble de la surface. Après avoir effectué le nettoyage susmentionné, il est nécessaire d’effectuer un lavage basique ou alcalin en utilisant des détersifs dégraissants. Cela car le lavage acide peut laisser une patine sur le sol qui pourrait contribuer à retenir la saleté.*

## DE\_ FUGEN UND VERFUGUNG

*Bei großen Räumen ist es unbedingt notwendig, in regelmäßigen Abständen Dehnungsfugen vorzusehen, während es in kleinen Räumen ausreicht, einen kleinen Abstand zwischen dem verfliesen Bereich und den Außenwänden zu lassen, der von der Sockelleiste verborgen werden wird. In jedem Fall ist es notwendig, dass der Planer oder Bauleiter die Arbeiten beaufsichtigt und überprüft, ob die Verlegung den in den einzelnen Ländern geltenden Vorschriften entspricht. Bei der Verwendung von Epoxidharzmörteln oder –fugenmassen mit Zusatz von Harzen oder ähnlichen Materialien ist es ratsam, die Anweisungen des Herstellers sorgfältig zu befolgen, da deren schnelle Aushärtung mehr Aufmerksamkeit erfordert. Wir halten es auch für wichtig, das Reinigungsmittel vor der Anwendung auf dem gesamten Boden zunächst auf einem Teil des Bodenbelags zu testen. Speziell für geläppte und polierte Produkte empfehlen wir die Verwendung von Fugenmörtel in einer zur Fliese passenden Farbe (z.B. weiße Fliesen mit schwarzer Fugenmasse vermeiden). Nach dem Verfugen der Feinsteinzeugfliesen ist es wichtig, solange die Fugenmasse noch feucht ist, sofort sorgfältig mit einem Schwamm die überschüssige Fugenmasse zu entfernen. Es ist jedoch unerlässlich, den Untergrund einige Tage nach der Verlegung, wenn die Fugen getrocknet sind, einer Grundreinigung mit gepufferten Säuren zu unterziehen (siehe folgendes Kapitel: Reinigung „nach der Verlegung“), um alle Baustellenreste vollständig zu entfernen. Beispiele für spezifische „saure“ Reinigungsmittel (Reinigungsmittel auf Säurebasis) für die Grundreinigung nach der Verlegung sind:*

- DETERDEK PRO FILA INDUSTRIA CHIMICA** www.filachim.com
- DELTA PLUS KERAKOLL** www.kerakoll.com
- KERANET MAPEI** www.mapei.it
- SERVICE ACIDO GEAL** www.geal-chim.it
- DISYCOTT FABER** www.faberchimica.com
- BONACLEAN BONASYSTEM** www.bonasytemsitalia.it

## GRUNDREINIGUNG „NACH DER VERLEGUNG“

**Feinsteinzeug***Die Grundreinigung „nach der Verlegung“ ist nach Abschluss der Arbeiten zwingend erforderlich. Die unsachgemäße oder verspätete Entfernung der zum Verfugen verwendeten Fugenmasse kann zu Schmutzrändern führen, die später schwierig zu entfernen sind und auf dem Bodenbelag einen Zementschleier hinterlassen, der alle Arten von Schmutz hartnäckig festhalten kann. Es ist unerlässlich, diese Rückstände mit Hilfe von wasserverdünnten, gepufferten Säuren aufzulösen und vollständig zu beseitigen (beachten Sie die Hinweise auf der Verpackung der verwendeten Produkte, die Rückstände müssen innerhalb kurzer Zeit sorgfältig durch das Nachspülen mit reichlich Wasser vom gesamten Bodenbelag vollständig entfernt werden). Das Waschen und Nachspülen sollte solange wiederholt werden, bis alle Schmutzränder oder Rückstände vollständig entfernt wurden. Wir empfehlen eine vorherige Testreinigung an einer kleinen Fläche von nur wenigen Quadratmetern durchzuführen. Im Falle eines positiven Ergebnisses kann dann die Reinigung der Gesamtfläche erfolgen. Sobald die Reinigung wie oben beschrieben erfolgt ist, muss eine Reinigung mit alkalischen Reinigungsmitteln erfolgen, dabei sind fettlösende Mittel zu verwenden. Dies ist notwendig, da saurehaltige Reiniger fettige Schlieren auf dem Boden zurücklassen könnten, die dazu beitragen könnten, Schmutz festzuhalten.*

## ES\_ JUNTAS Y REJUNTADO

*En los espacios de grandes dimensiones es absolutamente necesario colocar regularmente juntas de dilatación; mientras que, para las habitaciones pequeñas, es suficiente dejar un pequeño espacio entre el suelo de cerámica y las paredes perimetrales que será cubierto por el rodapié. De todas maneras, es necesaria la supervisión del diseñador o del director de obra que verifique que la instalación cumpla con las normas vigentes de cada país. Para el uso de productos epoxi de rejuntado o con resinas o similares, se recomienda seguir cuidadosamente las indicaciones de los fabricantes ya que su endurecimiento rápido requiere mayor atención. También consideramos que sea importante hacer una prueba previa de limpieza en una porción de suelo. Especialmente para los productos lapeados y pulidos sugerimos el uso de productos de rejuntado dentro de los matices de la cerámica (por ej., evitar las baldosas blancas con juntas negras). Después del rejuntado de las placas, cuando el producto todavía está fresco, es importante eliminar inmediatamente el exceso de producto de rejuntado con una esponja y abundante agua. De todas maneras, algunos días después de la colocación es indispensable limpiar la cerámica en profundidad utilizando ácidos tamponados (véase el siguiente capítulo: Limpieza “después de la colocación”) para eliminar por completo todos los residuos de obra. Algunos ejemplos de limpiadores a base de “ácido” específicos para la limpieza después de la colocación son:*

- DETERDEK PRO FILA INDUSTRIA CHIMICA** www.filachim.com
- DELTA PLUS KERAKOLL** www.kerakoll.com
- KERANET MAPEI** www.mapei.it
- SERVICE ACIDO GEAL** www.geal-chim.it
- DISYCOTT FABER** www.faberchimica.com
- BONACLEAN BONASYSTEM** www.bonasytemsitalia.it

### LIMPIEZA “DESPUÉS DE LA COLOCACIÓN”

**Gres porcelánico**

La limpieza “después de la colocación” es obligatoria al final de las obras. La eliminación inadecuada o tardía de los residuos de rejuntado puede dejar manchas difíciles de eliminar y crear una película cementosa en el suelo capaz de absorber todo tipo de suciedad. Es esencial disolver y eliminar completamente estos residuos con ácidos tamponados diluidos en agua (siempre siga las instrucciones de uso de los envases de los productos utilizados), que posteriormente deberán ser eliminados por completo en poco tiempo enjuagando a fondo todo el pavimento. Se recomienda repetir la operación de lavado y enjuague hasta que las marcas o residuos desaparezcan por completo. Sugerimos realizar un lavado preliminar en una superficie de muestra de algunos metros cuadrados; en caso de resultado positivo, limpie toda la superficie.Tras haber realizado el lavado antes mencionado, es necesario realizar un lavado básico o alcalino con limpiadores desengrasantes. Esto se debe a que el lavado con ácido puede dejar el suelo grasoso, lo que podría ayudar a retener la suciedad.

IT\_

**Rivestimento pasta bianca**

Il lavaggio dopo la posa è una fase di fondamentale importanza per tutti gli interventi successivi di manutenzione: con tale intervento si eliminano i residui di posa ed il normale sporco di cantiere come malta, colla, pittura etc. Una volta trascorsi i tempi di stagionatura dello stucco, procedere ad una pulizia con un detergente neutro attenendosi scrupolosamente alle istruzioni d'uso indicate sulla confezione dal produttore.

**Decorì ed inserti speciali con applicazioni materiche e/o metalli preziosi (oro - argento)**

Bisogna prestare molta attenzione nella fase della pulizia così come nella fase di posa; evitare assolutamente l'uso di prodotti abrasivi che potrebbero graffiare e danneggiare la superficie. Per la pulizia Ceramiche Keope consiglia di utilizzare unicamente panni morbidi con acqua calda e alcool.

**PULIZIA QUOTIDIANA**

Dopo avere effettuato la pulizia “dopo posa” (capitolo precedente), per la pulizia quotidiana si consiglia l'utilizzo di un detergente neutro. Sono da evitare i detergenti in commercio contenenti cere e additivi lucidanti che possono depositare sul pavimento patine indesiderate. È sconsigliato vivamente l'impiego di cere, saponi oleosi, impregnanti e trattamenti vari (idro-oleo repellenti) sul prodotto Ceramiche Keope, la cui applicazione non è necessaria. In presenza di suddetti trattamenti occorre innanzitutto asportarli dal pavimento utilizzando i prodotti specifici, seguendo le istruzioni riportate dal produttore. In caso di patine create da sapone, calcare, sporco, occorre invece utilizzare un detergente acido, opportunamente diluito in acqua (attenersi alle istruzioni sull'etichetta del prodotto). È opportuno segnalare che l'acido fluoridrico (HF) e derivati possono danneggiare irrimediabilmente le piastrelle. Per la pulizia ordinaria Ceramiche Keope consiglia l'utilizzo di varechina o ammoniaca, opportunamente diluite in acqua. Tutte le superfici lappate o levigate necessitano di un utilizzo di attrezzature non abrasive durante la fase di pulizia per prevenire opacizzazioni e graffiature. Si consiglia inoltre l'asciugatura del pavimento onde evitare la formazione di aloni.

EN\_

**White body wall coverings**

*It is essential to clean the tiles after laying for the purpose of all subsequent maintenance operations: in this way, any residues of grouting as well as the normal dirt created during building works are eliminated, such as mortar, adhesive, paint etc. Once the grouting has properly dried, clean the surface with a neutral detergent, complying strictly with the instructions for use on the box or package.*

***Decorative trims and special inserts with relief patterns and/or precious metals (gold – silver)***
*Great attention must be paid during both the cleaning phase and the laying phase; it is vital to avoid the use of abrasive products that might scratch or damage the surface. For the cleaning of surfaces in Ceramiche Keope, we recommend using exclusively a soft cloth with warm water and alcohol.*

**EVERYDAY CLEANING**
*Once the surface has been cleaned “after laying” (see previous chapter), for everyday cleaning we recommend the use of a neutral detergent.*

*Avoid using widely available detergents containing waxes and polishing additives that can deposit an undesired coating on the flooring. We strictly advise against the use of waxes greasy soaps, fillers and various treatments (water and oil repellent) on the Ceramiche Keope product, as they are not necessary. If the above treatments have been applied they will firstly need to be removed from the flooring using specific products following the manufacturer’s instructions. In the case of coatings created by soap, lime scale or dirt, you will need an acidic detergent, diluted in water as appropriate (always follow the instructions on the label). It should be noted that is hydrofluoric acid (HF) and its derivatives may damage the tiles permanently. For routine cleaning operations we recommend the use of bleach or ammonia, appropriately diluted in water. For all lapped or polished surfaces, the use of non-abrasive cleaning equipment is necessary to prevent the surface from losing its shine or becoming scratched. We also recommend leaving the floor to dry properly to prevent stains from forming.*

FR\_

**Revêtement en pâte blanche**

*Le lavage après la pose est une phase d’une importance fondamentale pour toutes les interventions successives d’entretien: il permet d’éliminer les résidus de pose et la saleté qui viennent inévitablement des travaux comme le mortier, la colle, la peinture, etc. Une fois que les délais de séchage du mastic sont écoulés, il faut procéder à un nettoyage à l’aide d’un détergent neutre en respectant scrupuleusement les instructions d’utilisation indiquées par le fabricant sur l’emballage.*

***Décorations et insertions spéciales avec applications de matières et/ou de métaux précieux (or – argent)***

*Il faut prêter une grande attention lors de la phase de nettoyage et de la phase de pose. Éviter absolument l’utilisation de produits abrasifs qui pourraient rayer et endommager la surface. Pour le nettoyage, Ceramiche Keope conseille d’utiliser uniquement des chiffons doux avec de l’eau chaude et de l’alcool.*

**NETTOYAGE QUOTIDIEN**

*Après avoir effectué le nettoyage « après la pose » (chapitre précédent), l’utilisation d’un détergent neutre est conseillée pour le nettoyage quotidien. Les détergents vendus dans le commerce, contenant des cires et des additifs brillants qui peuvent déposer sur le sol des patines indésirables, doivent être évités. Il est vivement déconseillé d’utiliser des cires, des savons oléagineux, des imprégnants et des traitements variés (hydrofuges et oléofuges) sur le produit Ceramiche Keope, dont l’application n’est pas nécessaire. En présence desdits traitements, il faut tout d’abord les faire disparaître du sol en utilisant des produits spécifiques, en suivant les instructions reportées par le fabricant. En cas de patines créées par du savon, du calcaire ou de la saleté, il faut au contraire utiliser un détergent acide, dilué de manière adaptée dans de l’eau (respecter les instructions indiquées sur l’étiquette du produit). Il convient de signaler que l’acide fluorhydrique (HF) et ses dérivés peuvent endommager irrémédiablement les carreaux. Pour le nettoyage ordinaire, Ceramiche Keope conseille l’utilisation d’eau de Javelou d’ammoniaque, diluées de manière adaptée dans de l’eau. Toutes les surfaces lustrées ou polies ont besoin d’être nettoyées avec des outils non abrasifs afin d’éviter les opacifications et les rayures. En outre, le séchage du sol est conseillé afin d’éviter la formation d’auréoles.*

DE\_

**Weißscherbige Wandfliesen**

*Die Reinigung nach der Verlegung ist von grundlegender Bedeutung für alle nachfolgenden Reinigungs- und Pflegearbeiten: Durch diesen Eingriff werden Verlegerückstände und normaler Baustellenschmutz wie Mörtel, Klebstoffe, Farbe usw. beseitigt. Sobald die Fugenmasse getrocknet ist, muss eine Grundreinigung mit einem neutralen Reinigungsmittel erfolgen, dabei sind die Anweisungen des Herstellers sorgfältig zu befolgen.*

***Dekore und spezielle Einsätze mit Materialapplikationen und/oder Edelmetallen (Gold - Silber)***

*Sowohl bei der Reinigung als auch bei der Verlegung ist Vorsicht geboten. Vermeiden Sie unbedingt die Verwendung von scheuernden Reinigungsmitteln oder Werkzeugen, die Kratzer und Beschädigungen der Oberfläche verursachen können. Zur Reinigung empfiehlt Ceramiche Keope, nur weiche Tücher mit heißem Wasser und Alkohol zu verwenden.*

**TÄGLICHE REINIGUNG UND PFLEGE**

*Nach der Reinigung „nach der Verlegung“ (voriges Kapitel) wird für die tägliche Reinigung die Verwendung eines neutralen Reinigungsmittels empfohlen. Gewerbliche Reinigungsmittel mit Wachsen und Polierzusätzen, die unerwünschte Beschichtungen auf dem Boden hinterlassen können, sollten vermieden werden. Wir raten von der Verwendung von Wachsen, öligen Seifen, Imprägniermitteln und sonstigen Behandlungen (zur Erzielung von wasser- und ölabweisenden Eigenschaften) auf dem Ceramiche Keope-Produkt ab, eine solche Behandlung ist nicht erforderlich. Sollten solche Behandlungen bereits erfolgt sein, müssen diese mit speziellen Produkten und unter Beachtung der Anweisungen des Herstellers vom Boden entfernt werden. Hat sich eine Patina aus Seife, Kalkstein und Schmutz gebildet, muss stattdessen ein saures, in Wasser verdünntes Reinigungsmittel verwendet werden (Hinweise auf dem Produktetikett beachten). Es ist zu beachten, dass Flusssäure (Fluorwasserstoffsäure) (HF) und Derivate die Fliesen irreparabel beschädigen können. Für die normale Reinigung empfiehlt Ceramiche Keope die Verwendung von Chlorbleiche oder Ammoniak, das mit Wasser verdünnt wird. Alle geläpften oder polierten Oberflächen erfordern den Einsatz von nicht abrasiven Werkzeugen während der Reinigung, um den Verlust des Glanzes und Kratzer zu vermeiden. Der Boden sollte nach der Reinigung getrocknet werden, um die Bildung von Schlieren zu vermeiden.*

ES\_

**Revestimiento de pasta blanca**

*El lavado después de la colocación es una etapa fundamental para todas las operaciones de mantenimiento posteriores: con dicha operación se eliminan los residuos de colocación y la suciedad normal de la obra, como morteros, adhesivos, pinturas, etc. Una vez transcurrido el tiempo de curado del producto de rejuntado, limpie con un limpiador neutro, siguiendo escrupulosamente las instrucciones de uso del envase del producto.*

***Decoraciones e insertos especiales con aplicaciones matéricas y/o metales preciosos (oro – plata)***

*Hay que tener mucho cuidado durante la etapa de limpieza así como durante la etapa de colocación; no utilice por ningún motivo productos abrasivos que podrían rayar y dañar la superficie. Para la limpieza, Ceramiche Keope recomienda utilizar únicamente paños suaves con agua caliente y alcohol.*

**LIMPIEZA DIARIA**

*Tras haber realizado la limpieza “después de la colocación” (capítulo anterior), para la limpieza diaria se recomienda utilizar un limpiador suave. Deben evitarse los limpiadores que contienen ceras y abrillantadores porque pueden depositar una película no deseada en el suelo. Se desaconseja usar ceras, jabones aceitosos, agentes de impregnación y tratamientos varios (hidro-óleo repelentes) en el producto Ceramiche Keope porque su aplicación no es necesaria. Ante la presencia de dichos tratamientos, en primer lugar es necesario eliminarlos del suelo utilizando los productos específicos, siguiendo las instrucciones dadas por el fabricante. En caso de películas creadas por jabón, cal y suciedad, es necesario utilizar un limpiador ácido, diluido adecuadamente en agua (siga las instrucciones de la etiqueta del producto). Cabe señalar que el ácido fluorhídrico (HF) y sus derivados pueden dañar irreparablemente las cerámicas. Para la limpieza ordinaria, Ceramiche Keope recomienda el uso de lejía o amoniaco diluidos adecuadamente en agua. Todas las superficies lapeadas o pulidas requieren el uso de equipos no abrasivos durante la etapa de limpieza para prevenir opacificaciones y rayados. También se recomienda secar el suelo para evitar que se formen marcas.*

IT\_

#### PULIZIA STRAORDINARIA

In caso di macchie particolari e/o particolarmente tenaci, è consigliabile l'uso di detersgenti specifici, come indicato nella “Tabella 1 - prodotti per la pulizia”. Non va inoltre dimenticato che la rimozione di qualsiasi tipo di macchia è più agevole quando questa è ancora fresca. È importante fare sempre un test preventivo prima dell'uso dei prodotti detersgenti, in particolare su gres porcellanato lappato o levigato.

EN\_

#### EXTRAORDINARY CLEANING

*In the case of particular and/or particularly stubborn stains, we recommend using specific detergents as those indicated in "Table 1 - cleaning products". It should furthermore not be forgotten that the removal of any type of stain is easier when the stain is still fresh. It is always important to test the detergents on a small area before applying to the entire surface, particularly in the case of porcelain stoneware with a lapped or polished finish.*

FR\_

#### NETTOYAGE SUPPLÉMENTAIRE

*Dans le cas de taches particulières et/ou particulièrement tenaces, il est conseillé d'utiliser des détergents spécifiques, comme indiqué dans le “Tableau 1 - produits pour le nettoyage”. En outre, il ne faut pas oublier que l'élimination de toute tache est plus simple lorsque celle-ci est encore fraîche. Il est important de toujours faire un test préalable avant l'utilisation des produits détergents, notamment sur grès cérame lustré ou poli.*

DE\_

#### BESONDERE REINIGUNG

*Bei besonderen oder besonders hartnäckigen Verschmutzungen sollten spezielle Reinigungsmittel verwendet werden, wie in der „Tabelle 1 - Reinigungsprodukte“ angegeben. Außerdem darf nicht vergessen werden, dass sich Flecken einfacher entfernen lassen, wenn sie noch frisch sind. Vor der Verwendung von Reinigungsmitteln, insbesondere bei geläpptem oder poliertem Feinsteinzeug, muss immer vorher ein Test durchgeführt werden.*

ES\_

#### LIMPIEZAS EXTRAORDINARIAS

*En caso de manchas particulares y/o muy tenaces, se recomienda utilizar limpiadores específicos, como indicado en la “Tabla 1 - productos de limpieza”. Tampoco hay que olvidarse de que la eliminación de cualquier tipo de mancha es más fácil cuando todavía está fresca. Es importante realizar siempre una prueba antes de usar los productos de limpieza, especialmente con el gres porcelánico lapeado o pulido.*

PRODOTTI PER LA PULIZIA / CLEANING PRODUCTS / PRODUITS POUR LE NETTOYAGE / REINIGUNGSPRODUKTE / PRODUCTOS DE LIMPIEZA

<b>Tipo di sporco /</b> <i>Type of dirt / Type de salete / Verschmutzung / Tipo de suciedad</i>	<b>Soluzione /</b> <i>Solution / Solution / Lösung / Solución</i>	<b>Detersgenti - Produttore /</b> <i>Detergents-Manufacturer / Detergents-Fabricants / Reinigungsmittel- Hersteller / Detergentes-Fabricante</i>
Calcare / <i>Limescale / Calcaire / Kalkausblühungen / Cal</i>		
Carbone / <i>Carbon / Charbon / Kohle / Carbón</i>		
Cemento / <i>Cement / Ciment / Zement / Cemento</i>		
Gesso / <i>Chalk / Plâtre / Gips / Yeso</i>		
Malta / <i>Mortar / Mortier / Mörtel / Argamasa</i>		
Matita / <i>Pencil / Crayon / Bleistift / Lápiz</i>	Soluzione acida / <i>Acid solution / Solution acide / Saurehaltig / Solucion ácida</i>	DETERDEK PRO / FILA SERVICE SOLVACID / GEAL CEMENT REMOVER / FABER KERANET / MAPEI DELTA PLUS / KERAKOLL BONACLEAN / BONASYSTEM
Residui metallici / <i>Metal residue / Résidu métallique / Metallreste / Residuo metal</i>		
Ruggine / <i>Rust / Rouille / Rost / Óxido</i>		
Stucco cementizio / <i>Cement grout / Ciment-joint / Zementmörtel / Estuco de cemento</i>		
Stucco colorato / <i>Coloured grout / Mortier coloré / Farbiger fugenmasse / Estuco colorado</i>		
Tempera murale / <i>Wall tempera / Détempres murales / Wandfarbe / Tempera mural</i>		
Birra / <i>Beer / Bière / Bier / Cerveza</i>		
Caffè / <i>Coffee / Café / Kaffee / Café</i>		
Coca cola / <i>Coke / Coca cola / Coca cola / Coca cola</i>		
Vino / <i>Wine / Vin / Wein / Vino</i>		
Gelato / <i>Ice cream / Glace / Eiscreme / Helado</i>		
Pneumatico / <i>Tire marks / Pneu / Gummi / Neumático</i>		
Grasso / <i>Fat / Grasses / Tierische fette / Grasa</i>		
Ketchup / <i>Ketchup / Ketchup / Ketchup / Ketchup</i>	Soluzione alcalina / <i>Alkaline solution / Solution alcaline / Alkalische lösung / Solucion alcalina</i>	PS87 PRO / FILA DETERFLASH / GEAL ALKALIN CLEANER / FABER AMMONIACA / UNIVERSALE
Maionese / <i>Mayonnaise / Mayonnaise / Mayonnaise / Mayonesa</i>		
Marmellata / <i>Jam / Confiture / Stau / Mermelada</i>		
Mostarda / <i>Mustard / Moutarde / Senf / Mostaza</i>		
Rossetto / <i>Lipstick / Rouge à lèvres / Lippenstift / Pintalabios</i>		
Suole di gomma / <i>Rubber soles / Huile de lin / Leinol / Suelas de goma</i>		
Tinture per capelli / <i>Hair dye / Teinture pour cheveux / Haarfärbemittel / Tintura para cabello</i>		
Urina / <i>Urine / Urine / Urin / Orina</i>		
Vomito / <i>Vomit / Vomi / Erbrochenes / Vómito</i>		
Alonatura ventose / <i>Stains from suction cups / Auréole de ventouses / Ränder von saugnapfen / Halos ventosas</i>		
Catrame / <i>Tar / Goudron / Teer / Alquitrán</i>		
Cera di candela / <i>Candle wax / Cire de bougie / Kerzenwachs / Cera de vela</i>		
Cera protettiva / <i>Protective wax / Cire protectrice / Schutzwachs / Cera protectiva</i>		
Colla / <i>Glue / Colle / Kleber / Pegamento</i>		
Gomma da masticare / <i>Chewing gum / Chewing-gum / Kaugummi / Goma de mascar</i>		
Inchiostro / <i>Ink / Encre / Tinte / Tinta</i>	Solvente / <i>Solvent / Lösungsmittel / Lösungsmittel / Disolvente</i>	SOLV / FILA SOLVENT STRIPPER / FABER ACETONE / UNIVERSALE TRIELINA / UNIVERSALE
Nastro adesivo / <i>Adhesive tape residue / Ruban adhésif / Klebeband / Cinta adhesiva</i>		
Oli / <i>oils / huiles / öl / Aceites</i>		
Pennarello / <i>marker pen / feutre / stifte / Rotulador</i>		
Resine / <i>resins / résines / harz / Resinas</i>		
Smalto per unghie / <i>nail polish / vernis à ongles / nagellack / Esmalte de uñas</i>		
Sigarette / <i>cigarette / cigarette / Zigaretten / Cigarrillo</i>		

**Per eventuali richieste specifiche contattare** / For any specific requests contact / Pour toute question spécifique, contactez / Für spezifische Anfragen kontaktieren Sie /

Para eventuales solicitudes específicas, contactar:

- FILA**  
www.filasolutions.com
- KERAKOLL**  
www.kerakoll.com
- MAPEI**  
www.mapei.it

- GEAL**  
www.geal-chim.it
- FABER**  
www.faberchimica.com
- BONASYSTEMS**  
www.bonasytemsitalia.it

**IT\_**
**POSA A SECCO PIASTRELLE K2 - 20MM**

• Le pavimentazioni da esterno posate a secco in quota sono soggette all'azione del vento, con il rischio di sollevamento delle lastre. Il produttore raccomanda di far verificare l'idoneità del sistema di posa in quota da un tecnico abilitato in base alla normativa locale vigente ed alle condizioni d'uso, al fine di evitare il rischio di danni a persone e cose.

• Una lastra ceramica posata su un sistema sopraelevato può rompersi per impatto qualora un oggetto pesante cada sulla stessa da una certa altezza, con il rischio di seri danni per chiunque possa sostare o transitare sulla piastrella stessa. Il mancato rispetto delle istruzioni fornite dal produttore relative alla posa su sistemi sopraelevati può provocare seri danni alla persone.

**ISTRUZIONI PER COMMITTENTI E PROGETTISTI**
Quando l'applicazione delle lastre in 20mm prevede l'utilizzo del prodotto ceramico in termini strutturali, si raccomanda al progettista e/o committente un'attenta valutazione dei requisiti del progetto in relazione alle caratteristiche tecniche delle lastre. In particolare, al fine di evitare il rischio di danni a persone o cose il produttore raccomanda:

• Se l'applicazione prevede la posa sopraelevata, tenendo conto che una piastrella potrebbe rompersi in seguito alla caduta su di essa di un corpo pesante, verificare anticipatamente la destinazione d'uso specifica e attenersi alla tabella istruzioni di posa sopraelevata di seguito riportata ove, in determinate condizioni, è prevista l'applicazione di un rinforzo sul retro della piastrella (rete plus o acciaio zincato) fornito dal produttore.

• Con riferimento alla pavimentazione posata in quota, con qualunque sistema di posa a secco, rispettare le specifiche normative e condizioni d'uso locali riguardanti, tra l'altro, a titolo esemplificativo, l'azione del vento, il carico strutturale, le azioni sismiche, ecc.

• Il mancato rispetto delle raccomandazioni soprariportate possono portare ad un utilizzo improprio del prodotto e causare eventualmente gravi danni a persone o cose.

**AVVERTENZA:**
**È bene prevedere le opportune pendenze trasversali e longitudinali da realizzare durante il livellamento o la compattazione per ottenere un drenaggio ottimale del piano di calpestio. Si raccomanda di prevedere un substrato realizzato con materiali drenanti per facilitare il deflusso dell'acqua ed evitarne il ristagno. Inoltre si consiglia una posa con fuga minima di 3 mm.**

Vista la caratteristica di ingelività del gres porcellanato, la serie K2 ha il valore relativo all'assorbimento d'acqua praticamente nullo. Tale proprietà potrebbe comportare ristagni di acqua localizzati sulla pavimentazione, indipendentemente dalla realizzazione di una posa a regola d'arte del materiale.

**EN\_**
**DRY LAYING K2 – 20MM**

• *Outdoor pavings installed unglued above the ground level are subject to the action of the wind, with the risk, in some cases, of becoming airborne. The manufacturer recommends to require the assistance of a qualified professional in order to check the suitability of the installation system above the ground adopted, in accordance with the local laws and regulations and the conditions of use. Failure to do so could result in serious injury or property damage.*

• *A ceramic slab installed on a raised pedestal system may fracture on impact if a heavy object is dropped onto it from a height, with a risk of injury to anyone standing or walking on such slab. Failure to adhere to the manufacturer’s instructions for installation of slabs on raised pedestal systems may result in serious injury.*

**INSTRUCTIONS FOR PROJECT ENGINEERS AND CUSTOMERS**

*If the application of the 20 mm slabs foresees the ceramic product used in structural installations, the project engineer and/or customer must carefully assess the project requirements with regard to the technical specifications of the slabs. To prevent the risk of damage or injury, the manufacturer recommends:*

• *With regard to a raised floor installation a ceramic slab may fracture on impact if a heavy object falls on it from any significant height. Therefore, the manufacturer recommends to check the specific intended use before starting the installation and to follow table for raised installation provided below (page 364). In certain conditions, reinforcing must be applied on the back of the slabs (double fiberglass mesh or galvanized steel sheet) supplied and applied by the manufacturer.*

• *With reference to any dry installation system of flooring above the ground level, the manufacturer recommends to comply with local regulations and conditions of use with regard to wind-load, loadbearing, seismic events, etc.*

• *Failure to comply with these recommendations may lead to improper use of the product and could cause serious damage or injury.*

**WARNING:**
**It is advisable to create the appropriate transverse and longitudinal gradients during levelling or compacting, in order to ensure optimal drainage of the floor.**

*We recommend the incorporation of a drainage substrate in order to facilitate runoff and prevent water pooling. It is also advisable to lay the tiles with a minimum joint of 3 mm.*

*Given the frost resistance of porcelain stoneware, the K2 series offers a water absorption value of practically zero. This property could lead to localised pooling of water on the floor, even if the tiles are laid properly.*

**FR\_**
**POSE À SEC DES DALLES K2 - 20MM**

• *Les dallages extérieurs posés sans collage sont soumis à l'action du vent, avec le risque de soulèvement des plaques, notamment ceux posés aux étages d'un bâtiment. Le fabricant recommande de faire vérifier par un technicien qualifié la bonne adaptation du système de pose en étages avec la réglementation en vigueur et les conditions d'utilisation locales, afin d'éviter le risque de dommages aux personnes et aux biens.*

• *Une dalle céramique posée sur un système surélevé peut se casser à la suite d'un impact d'un objet lourd qui y chuterait d'une certaine hauteur, avec le risque de sérieux dommages pour quiconque stationnerait ou transiterait sur ce carreau. Le non respect des instructions fournies par le fabricant relatives à la pose sur des systèmes surélevés peut provoquer de sérieux dommages aux personnes.*

**INDICATIONS ET AVERTISSEMENTS POUR CONCEPTEURS ET MAITRES D'OEUVRE**

*Lorsque la mise en œuvre de dalles de 20 mm prévoit l'utilisation du produit céramique en termes structurels, il est recommandé aux concepteurs, maîtres d'œuvre et/ou aux maîtres d'ouvrage de faire une évaluation scrupuleuse du cahier des charges du projet eu égard aux caractéristiques techniques des dalles. En particulier, afin d'éviter le risque de dommages aux personnes ou aux biens, le fabricant recommande:*

• *Si la mise en œuvre prévoit une pose surélevée, en tenant compte qu'un carreau pourrait se casser suite à la chute d'un corps lourd, de vérifier en avance la destination d'usage spécifique et de se conformer au tableau d'instructions de pose surélevée reproduit à la page 364, où, dans des conditions déterminées, il est prévu de rajouter un renforcement sur le revers du carreau (un treillis double en fibre de verre ou une feuille d'acier galvanisé), fourni par le fabricant.*

• *Concernant le dallage posé en étages, quelque soit le système de pose sans collage utilisé, de respecter les spécifications des normes et les conditions locales d'emploi, entre autre, à titre d'exemple, l'action du vent, le chargement structurel, les actions sismiques, etc.*

• *Le non respect des recommandations reproduites ci-dessus peut conduire à un usage impropre du produit et éventuellement causer de graves dommages aux personnes ou aux biens.*

**AVERTISSEMENT:**
**On conseille de prévoir des inclinaisons transversales et longitudinales opportunes à réaliser au cours du nivellement et du compactage pour obtenir un drainage optimal du plan de piétement. On recommande de prévoir un substrat réalisé avec des matériaux drainants pour favoriser l'écoulement de l'eau et en éviter la stagnation. On conseille également une pose avec un joint minimal de 3 mm.**

*Vu le caractère ingélif du grès cérame, la valeur d'absorption de l'eau de la série K2 est pratiquement nulle. Cette propriété pourrait provoquer des stagnations d'eau localisées sur le carrelage, indépendamment de la réalisation d'une pose du matériel dans les règles de l'art.*

**DE\_**
**TROCKENE VERLEGUNG K2 - 20MM**

• *Bodenbeläge die trocken im Außenbereich in der Höhe verlegt werden, unterliegen der Wirkung des Windes, wodurch die Gefahr besteht, dass die Platten aufgeworfen werden. Der Hersteller erteilt daher die Empfehlung, dass die Eignung des Systems für eine Verlegung in der Höhe durch einen zugelassenen Sachverständigen überprüft wird, wobei die lokal gültigen Vorschriften und Nutzungsbedingungen zu beachten sind, um die Gefahr von Personen- und Sachschäden zu vermeiden.*

• *Eine Keramikplatte die auf einem Doppelbodensystem verlegt ist, kann durch den Aufprall eines aus einer bestimmten Höhe herabfallenden Gegenstandes zerbrechen. Hier besteht das Risiko schwerer Verletzungen für all jene die auf der Fliese gehen, oder stehen. Bei Nichtberücksichtigung der vom Hersteller vorgegebenen Verlegevorschriften für Doppelbodensysteme, kann es zu schwerwiegenden Verletzungen der Personen kommen.*

**HINWEISE FÜR PLANER UND AUFTRAGGEBER**

*Falls der Einsatz der 20 mm Platten eine Verwendung des keramischen Produkts als Bestandteil der Gebäudestruktur vorsieht, ist der Planer und/oder der Auftraggeber angehalten, eine sorgfältige Prüfung der Voraussetzungen des Projekts in Bezug auf die technischen Eigenschaften der Platten vorzunehmen. Insbesondere zur Vermeidung der Gefahr von Personen- und Sachschäden, erteilt der Hersteller folgenden Hinweis:*

• *Unter Berücksichtigung des Umstandes, dass die Fliese infolge eines schweren herabfallenden Gegenstandes zerbrechen könnte, muss im Falle einer Anwendung als Doppelboden im voraus eine Prüfung des spezifischen Einsatzbereiches erfolgen. Außerdem ist die nachfolgende Tabelle mit Verlegeanweisungen zu berücksichtigen (Seite 364), die unter bestimmten Bedingungen die Aufbringung einer Verstärkung auf der Rückseite der Fliese vorsieht (Doppelglasfasernetz oder einen verzinkten Stahlblech) welche vom Produzenten geliefert wird.*

• *Mit Bezug auf Bodenbeläge die trocken im Außenbereich in der Höhe verlegt werden, sind die spezifischen lokalen Vorschriften und Nutzungsbedingungen zu berücksichtigen, die unter anderem, wie zum Beispiel für die Wirkung des Windes, der strukturellen Belastung, der Wirkung von Erdbeben, etc., vorgesehen sind; Die Nichtberücksichtigung der oben genannten Anweisungen kann zu einer unsachgemäßen Verwendung des Produkts führen und eventuell schwerwiegende Personen- und Sachschäden verursachen.*

• *Die Nichtberücksichtigung der oben genannten Anweisungen kann zu einer unsachgemäßen Verwendung des Produkts führen und eventuell schwerwiegende Personen- und Sachschäden verursachen.*

**HINWEIS:**

*Bei der Nivellierung und Kompaktierung müssen die notwendigen Quer- und Längsneigungen geschaffen werden, damit die ordnungsgemäße Drainage der Lauffläche möglich ist. Es wird empfohlen einen aus drainierendem Material bestehenden Unterboden vorzusehen, um das Abfließen des Wassers zu erleichtern und ein Anstauen zu vermeiden. Außerdem wird die Verlegung mit einer Mindestfuga von 3 mm empfohlen.*

*Aufgrund der Frostbeständigkeit des Feinsteinzeugs hat die Serie K2 einen Wasseraufnahmewert von praktisch Null. Diese Eigenschaft könnte, selbst bei fachgerechter Verlegung des Materials, zum Anstauen des Wassers auf dem Boden führen.*

**ES\_**
**COLOCACIÓN EN SECO K2 - 20MM**

• Los pavimentos de exteriores colocados en seco en altura están sometidos a la acción del viento, con el riesgo del levantamiento de las losas. El fabricante recomienda verificar la idoneidad del sistema de colocación en altura por un técnico autorizado en base a la normativa vigente localmente y a las condiciones de uso, a fin de evitar el riesgo de daños a personas y cosas.

• *Una losa cerámica colocada sobre un sistema sobreelevado puede romperse por impacto en caso de que un objeto pesado la golpee cayendo de una cierta altura, con el riesgo de serios daños para cualquiera que pueda encontrarse en la zona afectada. El no respeto de las instrucciones entregadas por el fabricante respecto a la colocación en sistemas sobreelevados puede provocar serios daños a las personas.*

**INSTRUCCIONES PARA CLIENTES Y PROYECTISTAS**

Cuando la aplicación de las losas de 20 mm contempla el empleo del producto cerámico en términos estructurales, se recomienda al proyectista y/o cliente una cuidadosa evaluación de los requisitos del proyecto en función de las características técnicas de las losas. En especial, a fin de evitar el riesgo de daños a personas o cosas el fabricante recomienda:

• Si la aplicación contempla la colocación sobreelevada, teniendo en cuenta que una baldosa podría romperse como consecuencia de la caída de un cuerpo contundente, verificar anticipadamente el destino de uso específico y seguir la tabla de instrucciones de la colocación sobreelevada presentada a continuación (p.364) en los casos en que, en determinadas condiciones, es prevista la aplicación de un refuerzo por el revés de la baldosa (doble red de fibra de vidrio o con una lámina de acero cincado) abastecida por el fabricante.

• Con referencia a la pavimentación colocada en altura, con cualquier sistema de colocación en seco, respetar las particulares normativas y condiciones de uso concernientes, entre otras cosas y en forma de ejemplo, la acción del viento, la carga estructural, las acciones sísmicas, etc.







• Si no se respetan las recomendaciones antedichas puede verificarse un uso impropio del producto que puede causar graves daños a personas o cosas.

**ADVERTENCIA:**
**Es conveniente prever las adecuadas inclinaciones transversales y longitudinales a realizar durante la nivelación o la compactación a fin de obtener un drenaje optimizado del plano de tránsito. Se recomienda instalar una subcapa realizada con materiales drenantes para facilitar la evacuación del agua y evitar estancamientos. Además se aconseja efectuar la colocación con fuga mínima de 3 mm.**

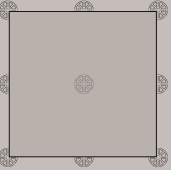
Vista la característica de resistencia al hielo del gres porcelánico, la serie K2 tiene valor relativo a la absorción de agua prácticamente nulo. Esta propiedad podría determinar estancamientos de agua localizados sobre el pavimento, independientemente de la efectiva correcta colocación del material.

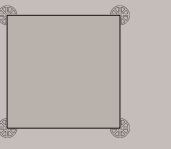

POSA A SECCO DI PIASTRELLE K2-20MM / DRY LAYING K2 – 20MM / POSE À SEC DES DALLES K2-20MM / TROCKENE VERLEGUNG K2-20MM / COLOCACIÓN EN SECO K2-20MM

Formato K2 - 20 MM / Size K2 - 20mm / Format K2 - 20 MM / Formaten K2 - 20 mm / Formatos K2 - 20 MM	Altezza fino a 2 cm / Up to 2 cm / Jusqu'à 2 cm / Höhe bis 2 cm / Altura hasta 2 cm	Altezza da 2 a 10 cm* / From 2 to 10 cm* / De 2 à 10 cm* / Höhe von 2 bis 10 cm* / Altura de 2 a 10 cm*	Altezza da 10 a 30 cm* / From 10 to 30 cm* / De 10 à 30 cm* / Höhe von 10 bis 30 cm* / Altura de 10 a 30 cm*
120x120 (48"x48")		9 piedi / 9 supports / 9 supports 9 stelzlager / 9 soportes + doppia rete di fibra di vetro plus o lamina di acciaio zincato. / + double fiberglass mesh or galvanized steel sheet. / + double filet en fibre de verre plus ou plaque en acier zingué. / + Doppelten glasfaser plus oder verzinkten stahlblech. / + Doble fibra de vidrio plus o lámina de acero cincado	9 piedi / 9 supports / 9 supports 9 stelzlager / 9 soportes + doppia rete di fibra di vetro plus o lamina di acciaio zincato. / + double fiberglass mesh or galvanized steel sheet. / + double filet en fibre de verre plus ou plaque en acier zingué. / + Doppelten glasfaser plus oder verzinkten stahlblech. / + Doble fibra de vidrio plus o lámina de acero cincado
60x120 (24"x48") 60x90 (24"x36") 45x90 (18"x36")		6 piedi / 6 supports / 6 supports 6 stelzlager / 6 soportes + doppia rete di fibra di vetro plus o lamina di acciaio zincato. / + double fiberglass mesh or galvanized steel sheet. / + double filet en fibre de verre plus ou plaque en acier zingué. / + Doppelten glasfaser plus oder verzinkten stahlblech. / + Doble fibra de vidrio plus o lámina de acero cincado	6 piedi / 6 supports / 6 supports 6 stelzlager / 6 soportes + doppia rete di fibra di vetro plus o lamina di acciaio zincato. / + double fiberglass mesh or galvanized steel sheet. / + double filet en fibre de verre plus ou plaque en acier zingué. / + Doppelten glasfaser plus oder verzinkten stahlblech. / + Doble fibra de vidrio plus o lámina de acero cincado
40x120 (16"x48")		6 piedi / 6 supports / 6 supports 6 stelzlager / 6 soportes + doppia rete di fibra di vetro plus o lamina di acciaio zincato. / + double fiberglass mesh or galvanized steel sheet. / + double filet en fibre de verre plus ou plaque en acier zingué. / + Doppelten glasfaser plus oder verzinkten stahlblech. / + Doble fibra de vidrio plus o lámina de acero cincado	6 piedi / 6 supports / 6 supports 6 stelzlager / 6 soportes + doppia rete di fibra di vetro plus o lamina di acciaio zincato. / + double fiberglass mesh or galvanized steel sheet. / + double filet en fibre de verre plus ou plaque en acier zingué. / + Doppelten glasfaser plus oder verzinkten stahlblech. / + Doble fibra de vidrio plus o lámina de acero cincado
30x120 (12"x48")		6 piedi / 6 supports / 6 supports 6 stelzlager / 6 soportes + doppia rete di fibra di vetro plus o lamina di acciaio zincato. / + double fiberglass mesh or galvanized steel sheet. / + double filet en fibre de verre plus ou plaque en acier zingué. / + Doppelten glasfaser plus oder verzinkten stahlblech. / + Doble fibra de vidrio plus o lámina de acero cincado	6 piedi / 6 supports / 6 supports 6 stelzlager / 6 soportes + doppia rete di fibra di vetro plus o lamina di acciaio zincato. / + double fiberglass mesh or galvanized steel sheet. / + double filet en fibre de verre plus ou plaque en acier zingué. / + Doppelten glasfaser plus oder verzinkten stahlblech. / + Doble fibra de vidrio plus o lámina de acero cincado
90x90 (36"x36") 80x80 (32"x32") 60x60 (24"x24")		4 piedi / 4 supports / 4 supports 4 stelzlager / 4 soportes + doppia rete di fibra di vetro plus o lamina di acciaio zincato. / + double fiberglass mesh or galvanized steel sheet. / + double filet en fibre de verre plus ou plaque en acier zingué. / + Doppelten glasfaser plus oder verzinkten stahlblech. / + Doble fibra de vidrio plus o lámina de acero cincado	4 piedi / 4 supports / 4 supports 4 stelzlager / 4 soportes + doppia rete di fibra di vetro plus o lamina di acciaio zincato. / + double fiberglass mesh or galvanized steel sheet. / + double filet en fibre de verre plus ou plaque en acier zingué. / + Doppelten glasfaser plus oder verzinkten stahlblech. / + Doble fibra de vidrio plus o lámina de acero cincado
30x60 (12"x24")		4 piedi / 4 supports / 4 supports 4 stelzlager / 4 soportes + doppia rete di fibra di vetro plus o lamina di acciaio zincato. / + double fiberglass mesh or galvanized steel sheet. / + double filet en fibre de verre plus ou plaque en acier zingué. / + Doppelten glasfaser plus oder verzinkten stahlblech. / + Doble fibra de vidrio plus o lámina de acero cincado	4 piedi / 4 supports / 4 supports 4 stelzlager / 4 soportes + doppia rete di fibra di vetro plus o lamina di acciaio zincato. / + double fiberglass mesh or galvanized steel sheet. / + double filet en fibre de verre plus ou plaque en acier zingué. / + Doppelten glasfaser plus oder verzinkten stahlblech. / + Doble fibra de vidrio plus o lámina de acero cincado

**IT\_**  
\* per USA, AUSTRALIA e CANADA: tutti i formati K2 - 20mm sono considerati adatti per la posa su supporti con altezza massima pari a 2 cm.

**FR\_**  
\* pour USA, AUSTRALIE et CANADA: toutes les formats K2 - 20mm sont considérées appropriées pour la pose sur des supports d'une hauteur maximale de 2 cm.

**EN\_**  
\* for USA, AUSTRALIA and CANADA: all sizes K2 - 20mm are considered suitable for laying on supports at a maximum height of 2 cm.

**DE\_**  
\* für USA, AUSTRALIEN und KANADA: alle Formaten K2 - 20 mm gelten als geeignet für die Verlegung auf Stützen mit einer maximalen Höhe von 2 cm.

**ES\_**  
\* para USA, AUSTRALIA y CANADÁ: todos los formatos K2 - 20 mm se consideran adecuados para colocar sobre soportes con una altura máxima de 2 cm.

**IT\_**  
Per richieste particolari e per avere informazioni specifiche relative alla doppia fibra di vetro o alla lamina di acciaio zincato da incollare sul retro, contattare il reparto tecnico di Ceramiche Keope. Per dettagli sul prodotto in 20 mm di spessore e sui relativi sistemi di posa ed, in particolare, per le raccomandazioni, accorgimenti, limitazioni di utilizzo e precauzioni in fase di posa, si raccomanda di prendere visione del catalogo K2 di Ceramiche Keope e del sito **keope.com**

**Nota:** Ceramiche Keope è responsabile esclusivamente nel caso in cui fornisca l'intero sistema (piastrella + doppia rete di fibra di vetro plus o lamina di acciaio). Ceramiche Keope non può essere ritenuta responsabile per sistemi di rinforzo delle lastre che non ha fornito. In caso di rottura, la lastra deve essere sostituita immediatamente.

**AVVERTENZA:**  
Ceramiche Keope a materiale già posato:  
• non accetta contestazioni dovuti a vizi palesi, così come definiti nella tabella 2 del presente manuale.  
• non risponde sulla qualità dell'opera piastrellata ma solamente sulle caratteristiche del materiale fornito. È bene conservare al termine della posa, alcune piastrelle di scorta per eventuali riparazioni o anche per disporre di un campione rappresentativo del materiale in caso di contestazione.

**FR\_**  
*Pour de plus amples détails sur les spécificités techniques du treillis plus ou de la plaque en acier zingué, nous vous invitons à contacter le bureau commercial de Ceramiche Keope. Pour de plus amples détails sur les produits de 20 mm d'épaisseur et sur leurs systèmes de pose, et en particulier, pour les recommandations, mises à jour, limitations d'usage et précautions en phase de pose, veuillez prendre connaissance du catalogue K2 de Ceramiche Keope et du site **keope.com***

**Note:** Ceramiche Keope n'est tenue responsable que dans le cas où elle fournit le système complet (dalle + treillis plus ou plaque d'acier zingué). Ceramiche Keope décline toute responsabilité en cas de renforts de dalles non fournis par ses soins. En cas de casse, la dalle doit être remplacée immédiatement.

**AVERTISSEMENT :**  
Ceramiche Keope, concernant le matériau déjà posé,  
• n'accepte pas les contestations dues à des vices apparents, définis dans le tableau 2 du présent manuel.  
• n'est pas responsable de la qualité du carrelage réalisé, mais uniquement des caractéristiques du matériau fourni.  
Il est conseillé de conserver, au terme de la pose, plusieurs carreaux à mettre de côté en vue de réparations éventuelles ou afin de disposer aussi d'un échantillon représentatif du matériau en cas de contestation.

**EN\_**  
*For further information and for technical specifications about the double fiberglass mesh and/ or the galvanized steel sheet to be applied on the back of the tile, to contact the Technical Department of Ceramiche Keope. For further details on the 20 mm product and the installation systems, in particular for recommendations, restrictions of use, and precautions during installation, please refer to the K2 catalogue and to the website **keope.com***

**Note:** Ceramiche Keope is responsible only if it supplies the whole system (tile + fiber mesh plus or galvanized sheet). Ceramiche Keope cannot be held responsible for reinforcing systems that has not supplied. In case of breakage, tile must be replaced immediately.

**WARNING:**  
*for material that has already been laid, Ceramiche Keope:*  
• does not accept any complaints for visible defects, as defined in table 2 of this manual  
• does not accept liability for the quality of the tiled surface but only for the characteristics of the material supplied.  
Once the material has been laid, it is wise to keep aside a few tiles for possible future repairs or to have a sample of the material in the event of complaints.

**DE\_**  
*Für weitere Informationen und für spezielle Informationen zu der doppelten Glasfaser oder zu dem verzinkten Stahlblech, das an die fliese geklebt wird, kontaktieren Sie bitte das Unternehmen. Für Details zum Produkt mit 20 mm Stärke und entsprechende Verlegesysteme, insbesondere hinsichtlich Hinweise und Anmerkungen, Nutzungseinschränkungen und Vorsichtsmaßnahmen während der Verlegung, wird die Einsicht des Katalogs K2 von Ceramiche Keope und der Webseite **keope.com** empfohlen.*

**Note:** Ceramiche Keope kann nur haftbar gemacht werden, wenn das ganze System (Fliese + Verstärkung) komplett geliefert worden ist. Ceramiche Keope kann nicht für Platten Verstärkungssysteme verantwortlich gemacht werden, die nicht geliefert wurden. Bei Bruch die Platte bitte sofort austauschen.

**HINWEIS:**  
Ceramiche Keope auf schon verlegten fliesen und platten:  
• Ceramiche Keope akzeptiert keine beanstandungen aufgrund offensichtlicher mängel, wie in tabelle 2 dieses handbuchs definiert.  
• Ceramiche Keope ist nicht für die qualität der fliesenarbeiten verantwortlich, sondern nur für die eigenschaften des gelieferten materials.  
Es ist ratsam, einige ersatzfliesen am ende der installation für eventuelle reparaturen aufzubewahren oder im falle einer reklamation auf diese weise ein repräsentatives muster des materials zur hand zu haben.

**ES\_**  
*Para más detalles y para obtener informaciones específicas respecto de la doble fibra de vidrio plus o de la lámina de acero cincado a pegar en el revés de la baldosa, rogamos ponerse en contacto con el departamento técnico de Ceramiche Keope. Para mayores informaciones sobre el producto de 20 mm de espesor y sobre los relativos sistemas de colocación y, en especial, para las recomendaciones, precauciones y límites de empleo en fase de colocación, se recomienda consultar el catálogo K2 y el sitio **keope.com***

**Nota:** Ceramiche Keope es responsable solo si ha abastecido el sistema completo (baldosa + refuerzo). No puede ser considerada responsable por sistemas de refuerzo que no ha abastecido. En caso de ratura, la losa tiene que ser reemplazada inmediatamente.

**ADVERTENCIA:**  
Ceramiche Keope, con el material ya colocado:  
• no acepta reclamaciones debidas a vicios evidentes, así como definidos en la tabla 2 de este manual.  
• no responde sobre la calidad de la obra sino que responde únicamente de las características del material suministrado.  
Se recomienda conservar después de la colocación algunas cerámicas de repuesto para posibles reparaciones o incluso para tener una muestra representativa del material en caso de reclamación.

Causale / Type of defect Motif / Grund / Defecto	Descrizione / Description Description / Beschreibung / Descripción	Eccezioni / Exceptions Exceptions / Ausnahmen / Excepciones
Calibro / Caliber Calibre / Werkmaß / Calibre	Piastrelle di dimensioni (Larghezza/Lunghezza) differenti all'interno dello stesso lotto (Calibro/Caliber) con deviazioni superiori alle tolleranze rivendicate in scheda tecnica. / Tiles with different dimensions (Width/Length) in the same batch (Caliber), with deviations exceeding the tolerances claimed on the technical specification sheet. / Carreaux de dimensions différentes (Largeur/Longueur) à l'intérieur du même lot (Calibre) avec des déviations supérieures aux tolérances indiquées dans la fiche technique. / Fliesen verschiedener Abmessungen (Breite/Länge) innerhalb eines Loses (Werkmaß), wobei die Abweichungen die im technischen Datenblatt angegebenen Toleranzen überschreiten. / Cerámicas de diferentes medidas (Ancho/Largo) pertenecientes al mismo lote (Calibre) con diferencias superiores a las tolerancias indicadas en la ficha técnica.	-
Planarità / Planarity Planéité / Ebenheit / Planicidad	Piastrelle concave o convesse (curvatura dello spigolo), con angoli rialzati o abbassati (svergolamento) con deviazioni superiori rispetto alle tolleranze rivendicate in scheda tecnica. / Tiles that are concave or convex (curved at the edges), have raised or lowered corners (warpage) with deviations exceeding the tolerances claimed on the technical specification sheet. / Carreaux concaves ou convexes (courbure de l'arête), avec des angles rehaussés ou abaissés (gauchissement)avec des déviations supérieures aux tolérances indiquées dans la fiche technique. / Konkave oder konvexe Fliesen (Krümmung der Kante), mit erhöhten oder abgesenkten Winkeln (verzogene Fliesen), wobei die Abweichungen die im technischen Datenblatt angegebenen Toleranzen überschreiten. / Cerámicas cóncavas o convexas (curvatura del canto), con esquinas curvadas hacia arriba o hacia abajo (pandeo) con diferencias superiores a las tolerancias indicadas en la ficha técnica.	-
Ortogonalità - Rettilinearità / Orthogonality-Straightness / Orthogonalité-Rectitude / Rechtwinkligkeit-Geradlinigkeit / Ortogonalidad-Rectitud	Piastrelle con lati non rettilinei e non ortogonali ("effetto trapezio") con deviazioni superiori rispetto alle tolleranze rivendicate in scheda tecnica. / Tiles with edges that are not straight (and not orthogonal ("trapezoid effect") with deviations exceeding the tolerances claimed in the technical specification sheets. / Carreaux avec des bords non rectilignes et non orthogonaux (« effet trapèze ») avec des déviations supérieures aux tolérances indiquées dans la fiche technique. / Fliesen mit nicht geraden und nicht rechtwinkligen Seiten („Trapezeffekt“), wobei die Abweichungen die im technischen Datenblatt angegebenen Toleranzen überschreiten. / Cerámicas con lados no rectos y no ortogonales ("efecto trapezio") con diferencias superiores a las tolerancias indicadas en la ficha técnica.	-
Spessore / Thickness Épaisseur / Stärke / Espesor	Piastrelle con spessore differente all'interno della stessa scatola con deviazioni superiori rispetto alle tolleranze rivendicate in scheda tecnica. / Tiles with differing thicknesses in the same box with deviations exceeding the tolerances claimed on the technical specification sheet. / Carreaux d'épaisseurs différentes à l'intérieur de la même boîte avec des déviations supérieures aux tolérances indiquées dans la fiche technique. / Fliesen mit unterschiedlicher Stärken innerhalb einer Kiste, wobei die Abweichungen die im technischen Datenblatt angegebenen Toleranzen überschreiten. / Cerámicas con diferentes espesores dentro de la misma caja con diferencias superiores a las tolerancias indicadas en la ficha técnica.	-
Crepe / Cracks Craquelures / Risse / Grietas	Piastrelle con crepe parallele o ortogonali al bordo oppure superficiali con immediato distacco di placche superficiali dopo battitura. / Tiles with cracks running parallel or orthogonally to the edge, or surface cracks leading to the immediate detachment of bits of the surface coating when the tiles are tapped to level the surface. / Carreaux avec des craquelures parallèles ou orthogonales sur leur bord ou leur surface avec un détachement immédiat de plaques superficielles après le battage. / Fliesen mit parallelen oder rechtwinkligen Rissen an den Kanten oder auf der Oberfläche mit sofortigem Abplatzen von oberflächlichen Stückchen beim Anklopfen. / Cerámicas con grietas paralelas o perpendiculares al canto o superficiales con desprendimiento inmediato de las placas superficiales después del golpeo.	-
Sbeccature / Chipping Fissures / Dellen, angeschlagene fliesen / Desconchados	Piastrelle con angoli e/o bordi rotti dentro alle scatole. / Tiles with broken corners and/or edges inside the box. / Carreaux avec des angles et/ou des bords cassés à l'intérieur des boîtes. / Fliesen mit angeschlagenen Ecken und/oder Kanten in den Kisten. / Cerámicas con esquinas rotas y/o cantos rotos dentro de las cajas.	-

Causale / Type of defect Motif / Grund / Defecto	Descrizione / Description Description / Beschreibung / Descripción	Eccezioni / Exceptions Exceptions / Ausnahmen / Excepciones
Difetti superficiali / Surface defects Défauts de surface / Oberflächliche Mängel / Defectos de superficie	Piastrella con buchi, spillature, crateri, vulcani, avvallamenti, inquinamento di impasto e presenza della marca (impressa dal retro del materiale ceramico) sulla superficie di esercizio / Tiles with (pin) holes, depressions, dimples, puckering, any contamination in the ceramic body; visible signs of brands/trademarks (left by the back of other ceramic tiles) on the surface. / Carreaux avec trous, coulées, creux, bosses, dépressions, contamination de la pâte et avec présence de la marque (imprimée par le dos du matériau céramique) sur la surface d'utilisation. / Fliese mit Löchern, kleinen nadelstichförmigen Vertiefungen, Kratern, Einsenkungen, verschmutzter Masse und Sichtbarkeit der Marke (durchgedrückt von der Rückseite des Keramikmaterials) auf der Oberfläche. / Cerámicas con agujeros, puntos, cráteres, volcanes, depresiones, contaminación de la masa y presencia de la marca (grabada en el reverso de la cerámica) en la superficie superior.	Il segno delle ventose visibile solo in condizioni di umidità per pochi secondi non viene considerato come difetto della piastrella in quanto nelle normali condizioni di esercizio non si percepisce. / If suction pads leave visible signs for a few seconds in humid conditions, this is not considered a defect of the tile, as such signs are not visible in normal conditions. / La marque des ventouses, visible uniquement dans des conditions d'humidité pendant quelques secondes, n'est pas considérée comme un défaut dans la mesure où celle-ci ne se voit pas dans des conditions normales d'utilisation. / Die nur bei Feuchtigkeit für einige Sekunden sichtbare Saugnapfmarkierung gilt nicht als Mangel der Fliese, da sie unter normalen Bedingungen nicht wahrgenommen wird. / La marca de las ventosas visible solo en condiciones de humedad durante unos segundos no se considera un defecto de la placa ya que en condiciones normales de servicio no se percibe.
Difetto di decorazione / Decorative defects Défaut de décoration / Dekorationsmängel / Defecto de decoración	Piastrelle con difetti di serigrafia, di smalto, gocce, righe della digitale / Tiles with defects in the silk-screen printing, glazing, droplets and lines created during digital printing. / Carreaux avec des défauts de sérigraphie, d'émail, de gouttes et de lignes de la machine numérique. / Fliesen mit Fehlern im Druck, der Glasur, Tropfen, Streifen bei Digitaldruck. / Cerámicas con defectos de serigrafía, esmalte, gotas, líneas de la decoración digital.	-
Fuori tono / Colour defects Hors ton / Farbtonfehler / Fuera de tono	Piastrelle con tono eccessivamente diverso dal riferimento e/o campione fornito al cliente. / Tiles with a tone of colour that differs excessively from the reference piece and/or sample provided to the customer. / Carreaux avec un ton excessivement différent de la référence et/ou de l'échantillon fourni au client. / Fliesen mit einem Ton, der sich zu sehr von der Referenz und/oder dem Muster unterscheidet, das dem Kunden geliefert wurde. / Cerámicas con un tono que es muy diferente al producto de referencia y/o a la muestra suministrada al cliente.	-
Toni mescolati / Mixed tones Tons / Mélangés / Vermischte farbtöne / Tonos mezclados	Piastrelle all'interno dello stesso lotto con un grado di stonalizzazione superiore al V-Shade riportato a catalogo. / Tiles in the same batch with a colour shading level above the V-Shade stated in the catalogue. / Carreaux à l'intérieur du même lot avec un degré de dénuançage supérieur au V-Shade mentionné dans le catalogue. / Fliesen innerhalb derselben Partie mit Farbabweichungen, die größer sind als der im Katalog angegebene V-Shade-Wert. / Cerámicas del mismo lote con un grado de destonalización superior al V-Shade indicado en el catálogo.	-
Difetto di lappatura-levigatura / Lapping-polishing defects / Défaut de lustrage-polissage / Lappungs-polierfehler / Defecto de lapeado-pulido	Piastrelle con "bucatura" eccessiva, "pelate" (affioramento del colore dell'impasto), bordi graffiati e/o opachi, graffi superficiali di forma semicircolare / Tiles on which the surface presents an excessive number of "pinholes" or appears to "peel" (the colour of the ceramic body resurfaces), that have scratched and/or opaque edges, surface scratches of a semicircular shape, ... / Carreaux avec une quantité excessive de trous, « pelades » (apparition de la couleur de la pâte), bords rayés et/ou opaques, rayures superficielles de forme semi circulaire, ... / Fliesen mit übermäßigen Einstichen abgeblätterte Fliesen (Farbe des Scherbens schlägt durch), verkratzte und/oder matte Kanten, halbrunde oberflächliche Kratzer usw. / Cerámicas con "orificios" excesivos, con afloramiento del color del cuerpo, cantos rayados y/o opacos, rayas en la superficie de forma semicircular, etc.	-
Problemi di taglio-scaglie / Cutting problem-flaking / Problèmes de coupe-écailles / Schnittprobleme-splitter / Problemas de corte-descascarillado	Piastrelle che si scheggiano, scagliano, rompono durante il taglio lineare e/o foratura quadrangolare e/o circolare. / Tiles that chip, flake or break when straight cuts or rectangular/round holes are made in the tile. / Carreaux qui s'ébrèchent, s'écaillent et se brisent durant la coupe linéaire et/ou la perforation quadrangulaire et/ou circulaire. / Fliesen, die beim geraden Zuschnitt und/oder dem Anbringen von quadratischen und/oder kreisförmigen Bohrungen brechen. / Cerámicas que se astillan, descascarillan, se rompen durante el corte lineal y/o durante la perforación cuadrangular o circular.	-

Causale / Type of defect Motif / Grund / Defecto	Descrizione / Description Description / Beschreibung / Descripción	Eccezioni / Exceptions Exceptions / Ausnahmen / Excepciones
Crepe-scatoloni-sfilato / Cracks-blistering / Craquelures-décrochages superficiels / Risse-abblättern / Grietas-desventados	Piastrelle che successivamente alla posa manifestano crepe parallele o ortogonali al bordo oppure superficiali ("scatolone"). / Tiles which (after laying) present cracks that run parallel or orthogonally to the edge or surface cracks ("blistering")./ Carreaux qui, après la pose, manifestent des craquelures parallèles ou orthogonales sur leur bord ou leur surface (« <span> </span> décrochage superficiel <span> </span> »). / Fliesen, die nach der Verlegung Risse parallel oder orthogonal zur Kante oder oberflächliche Risse („abplatzende Hohlstellen“) aufweisen. / Cerámicas que después de la colocación presentan grietas paralelas o perpendiculares al canto o superficiales (“desventada”).	Attenzione perché le rotture delle piastrelle tagliate per il perimetro della pavimentazione, il più delle volte, sono conseguenza di mancati accorgimenti nel taglio e/o nella della ceramica. / Great care should be taken when cutting and laying ceramic tiles around edges and other objects, as breakages are often due to the failure to take appropriate precautions. / Attention car les ruptures des carreaux coupés pour le périmètre du sol, le plus souvent, sont la conséquence d'un manque de précautions au moment de la coupe et/ou la pose de la céramique. / Gehen Sie mit dem Material vorsichtig um, denn der Bruch der Fliesen, die für den Bodenbelag zugeschnitten wurden geht meistens auf mangelnde Aufmerksamkeit beim Schneiden und/oder Verlegen zurück. / La rotura de las baldosas cortadas para el perimetro del suelo, la mayoría de las veces, son el resultado de la falta de precauciones durante el corte y/o la colocación de la cerámica.

Cavillo tardivo / Subsequent crackling / Tressaillage à effet retardé / Spätere haarrisse / Cuarteo diferido	Piastrelle smaltate da rivestimento che manifestano fenomeni di cavillo "tardivo" dopo alcuni mesi dalla posa in opera. / Glazed wall tiles on which the phenomenon of crackling starts to appear "subsequently", even several months after laying. / Carreaux émaillés pour revêtement qui présentent des phénomènes de tressaillage « <span> </span> à effet retardé <span> </span> », quelques mois après la pose. / Emaillierte glasierte Wandfliesen, die wenige Monate nach der Verlegung Haarrisse zeigen. / Cerámicas esmaltadas de revestimiento que presentan fenómenos de cuarteo "diferido" después de unos meses de la colocación.	Questo difetto può essere dovuto alla ceramica ma il più delle volte alla posa non eseguita "a regola d'arte". / This defect may be due to the ceramic product, but is normally caused by improper laying of the tiles. / Ce défaut peut être dû à la céramique mais il est le plus souvent dû à la pose qui n'a pas été réalisée dans « <span> </span> les règles de l'art <span> </span> ». / In diesen Fällen kann die Keramik mangelhaft sein, aber meistens gehen diese Probleme auf die nicht „fachmännisch“ durchgeführte Verlegung zurück. / Este defecto puede deberse a la cerámica, pero la mayoría de las veces se debe a una colocación incorrecta.

Danneggiamento da gelo / Frost damage / Déterioration due au gel / Frostschäden / Daños por hielo	Piastrelle che dopo alcuni mesi dalla posa in esterno mostrano la comparsa di fratture e scagliature abbastanza tipiche della ceramica, il più delle volte di tipo "concoide". / Tiles laid outside that start to show fractures and flaking typical of ceramic tiles, often of the "conchoidal" type. / Carreaux qui, quelques mois après la pose en extérieur, montrent l'apparition de fractures et d'écaillassez typiques de la céramique, le plus souvent de type « <span> </span> conchoïde <span> </span> ». / Fliesen, bei denen einige Monate nach der Verlegung Brüche oder - meist muschelförmige - Absplütterungen auftreten, wie sie recht typisch für Keramik sind. / Cerámicas que después de algunos meses de la colocación en exteriores presentan fracturas y descascarilladas bastante típicas de la cerámica, la mayoría de las veces tipo "concoidea".	Il distacco e/o sollevamento di piastrelle posate in esterno come pure la rottura di piastrelle singole e/o adiacenti fra loro non è da imputare alla ceramica ma ad una errata installazione. / If tiles laid outdoors become detached from the substrate or raised, or if individual and/or adjacently laid tiles break, this is not due to the ceramic product but to incorrect laying. / Le détachement et/ou soulèvement de carreaux posés à l'extérieur ainsi que la rupture de carreaux individuels et/ou placés les uns à côté des autres ne sont pas dus à la céramique mais à une installation incorrecte. / Das Ablösen und/oder Abheben von im Außenbereich verlegten Fliesen sowie der Bruch einzelner und/oder benachbarter Fliesen ist nicht auf die Keramik, sondern auf eine fehlerhafte Verlegung zurückzuführen. / El despegue y/o levantamiento de baldosas colocadas en exteriores, así como la rotura de baldosas individuales y/o adyacentes entre sí no se deben atribuir a la cerámica sino a una colocación incorrecta.

Macchiabilità / Inclination to stains / Salissure / Fleckenempfindlichkeit / Manchas	Piastrelle che trattengono in modo anomalo lo sporco e risultano essere di difficile pulibilità. / Tiles that trap dirt to an excessive extent and are difficult to clean. / Carreaux qui retiennent de manière anormale la saleté et s'avèrent être difficiles à nettoyer. / Fliesen, die Schmutz auf ungewöhnliche Weise zurückhalten und schwer zu reinigen sind. / Cerámicas que retienen la suciedad de forma anormal y son difíciles de limpiar.	Verosimilmente si tratta di un difetto occulto ma c'è da verificare se è dovuto a prestazioni inadeguate del materiale ceramico installato e/o errata manutenzione del cliente finale. / This is probably due to a hidden defect, but it is also necessary to check if this is due to insufficient characteristics of the tile used for the purpose, and/or incorrect maintenance on the part of the end customer. / Il s'agit vraisemblablement d'un vice caché mais il faut vérifier si celui-ci est dû à des prestations inadaptées du matériau céramique installé et/ou à un entretien incorrect effectué par le client final. / Es handelt sich wahrscheinlich um einen versteckten Mangel, aber es muss geprüft werden, ob er auf eine unzureichende Leistung des verlegten Materials und/oder eine fehlerhafte Pflege durch den Endkunden zurückzuführen ist. / Probablemente se trata de un defecto oculto, pero hay que comprobar si se debe a prestaciones inadecuadas del material cerámico instalado y/o a un mantenimiento incorrecto del cliente final.

#### IT\_ **NORMATIVA UNI 11493-2013**

Il presente manuale è stato redatto nel rispetto della norma nazionale UNI 11493 del 2013 che regola la posa delle piastrelle ceramiche a pavimento e a parete, per interni ed esterni, installate principalmente con adesivi, ma anche con malta cementizia o altri sistemi. Lo scopo della norma, che si pone comunque come un testo di riferimento per il settore, è quello di assicurare il raggiungimento di un alto livello qualitativo e il suo mantenimento nel tempo.

Questo manuale descrive situazioni puramente indicative e non intende sostituire in alcun modo né le normative in materia di igiene e sicurezza sul lavoro in vigore in ciascun Paese, né le prescrizioni, le avvertenze e le raccomandazioni contenute nelle schede e nei manuali di prodotti, utensili, macchinari e impianti utilizzati, alle quali è sempre necessario attenersi. La loro attenta lettura e comprensione da parte di personale tecnico qualificato, insieme all'utilizzo di dispositivi di protezione individuale, è fondamentale per uno svolgimento delle attività corretto e sicuro.

#### FR\_ **RÈGLEMENT UNI 11493-2013**

*Ce manuel a été rédigé conformément au règlement national UNI 11493 de 2013 concernant la pose de carreaux de céramique sur des sols ou des murs, pour l'intérieur ou l'extérieur, généralement à l'aide de mortier-colle, mais aussi de mortier de ciment ou d'autres produits. Le but de ce règlement, qui a pour vocation de servir de texte de référence pour notre secteur d'activité, est de garantir un haut niveau de qualité, durable à long terme.*

*Ce manuel rend compte de situations purement indicatives et ne vise aucunement à remplacer les règlements en vigueur dans chaque pays en matière d'hygiène et de sécurité sur le lieu de travail, ni les prescriptions, avertissements et conseils contenus dans les fiches et les manuels des produits, outils, machines et appareils utilisés, qui doivent toujours être consultés et respectés. Une lecture attentive de ces derniers et leur compréhension par le personnel technique qualifié, ainsi que l'utilisation d'équipements de protection individuelle sont essentielles pour la bonne exécution des travaux, en conditions de sécurité.*

#### EN\_ **UNI 11493-2013**

*This manual has been written in conformity to Italian standard UNI 11493 of 2013 governing the installation of ceramic floor and walls tiles in indoor and outdoor applications, mainly with adhesive but also with cement-based mortar or other systems. The purpose of UNI 11493 standard is to serve as a reference for the ceramic tile sector and to ensure the respect and maintenance of the highest quality standards over time.*

*This manual describes purely indicative situations and is not intended to replace Italian standards governing hygiene and safety in the workplace or the instructions, precautions and recommendations provided in the data sheets and manuals of products, tools, machines and equipment, which must always be respected. The thorough application of such standards and instructions by qualified technical person and the use of suitable personal protective equipment is essential to the correct and safe completion of tile installation work.*

#### DE\_ **NORM UNI 11493-2013**

*Die vorliegende Anleitung wurde in Anlehnung an die italienische Norm UNI 11493 aus dem Jahr 2013 verfasst, in der die Verlegung von Boden- und Wandkeramikfliesen für Innen- und Außenbereiche reglementiert ist; die Verlegung erfolgt hauptsächlich mit Klebern, kann aber auch mit Zementmörtel oder unter Anwendung anderer Systeme ausgeführt werden. Die Ziele der Norm, die auf jeden Fall als Bezugsdokument für den betreffenden Sektor gilt, sind die Sicherstellung eines hohen qualitativen Niveaus und die langfristige Einhaltung dieses Niveaus.*

*In dieser Anleitung sind Standardsituationen beschrieben; sie ist kein Ersatz für die einschlägigen und in den jeweiligen Ländern geltenden Normen hinsichtlich Hygiene und Sicherheit am Arbeitsplatz oder für Vorschriften, Warnungen und Empfehlungen, die in den Datenblättern und Anleitungen der verwendeten Produkte, Werkzeuge, Maschinen und Anlagen enthalten sind und auf jeden Fall immer beachtet werden müssen. Die sorgfältige Lektüre und das Verständnis des jeweiligen Inhalts vonseiten der qualifizierten Fachkräfte und die Verwendung angemessener persönlicher Schutzausrüstungen sind für eine korrekte und sichere Ausführung der Arbeiten unabdingbar.*

#### ES\_ **NORMA UNI 11493-2013**

*Este manual ha sido elaborado en cumplimiento de la norma nacional UNI 11493 de 2013, que regula la colocación de lasas cerámicas en pisos y paredes, para interiores y exteriores, instaladas principalmente con adhesivos, pero también con mortero de cemento u otros sistemas. El objetivo del Reglamento, que en cualquier caso es un texto de referencia para el sector, es garantizar que se alcance y mantenga un alto nivel de calidad a lo largo del tiempo.*

*Este manual describe situaciones puramente indicativas y no pretende en modo alguno sustituir a la normativa de seguridad y salud laboral vigente en cada país, ni a los requisitos, las advertencias y las recomendaciones contenidos en las hojas de datos y los manuales de los productos, las herramientas, la maquinaria y los sistemas utilizados, que deben respetarse en todo momento. Su cuidadosa lectura y comprensión por parte de personal técnico cualificado, junto con el uso de equipos de protección personal, es esencial para llevar a cabo las actividades de forma correcta y segura.*

# CONDIZIONI GENERALI DI VENDITA / Rev.1a - 01 Gennaio 2018

## A.- MODALITA' DI CONCLUSIONE DEL CONTRATTO

A.1.- Le presenti Condizioni Generali di Vendita disciplinano ogni contratto di Vendita tra il Venditore e l'Acquirente ed ogni loro modifica o deroga deve essere concordata per iscritto.

A.2.- Eventuali offerte, accrediti e/o abbuoni accordati da agenti o da altri intermediari, non sono ritenuti validi se non confermati per iscritto dal Venditore.

A.3.- L'Acquirente invia al Venditore, direttamente o per il tramite di agenti, Ordini scritti che devono contenere l'indicazione dei codici dei Prodotti richiesti, delle quantità, del loro prezzo e della destinazione. L'Ordine inviato dall'Acquirente è irrevocabile.

A.4.- La Vendita dovrà ritenersi conclusa nel momento in cui: (i) l'Acquirente riceva da parte del Venditore una Conferma scritta via e-mail, fax o altri mezzi telematici, conforme ai termini e alle condizioni dell'Ordine; o (ii) in caso di Conferma inviata dal Venditore contenente condizioni difformi dall'Ordine ricevuto dall'Acquirente quando questi l'accetti per iscritto o comunque non la contesti entro 7 (sette) giorni dalla ricezione; o (iii) in assenza di conferma scritta da parte del Venditore, nel momento in cui i Prodotti saranno consegnati e caricati dall'Acquirente.

## B.- PREZZI

B.1.- Salvo diversa pattuizione scritta, i prezzi di vendita concordati di volta in volta si intendono al netto per contanti e per consegna franco stabilimento del Venditore indicato nella Conferma d'Ordine.

## C.- CARATTERISTICHE DEI PRODOTTI

C.1.- L'Acquirente dichiara di aver preso visione ed attenersi al contenuto della seguente documentazione pubblicata nel sito internet aziendale: 1) Manuale di Posa, Uso, Pulizia e Manutenzione e 2) Schede tecniche.

C.2. Data la intrinseca variabilità del prodotto ceramico, le caratteristiche dei campioni e/o modelli inviati in precedenza dal Venditore all'Acquirente sono da considerarsi indicativi e non vincolanti.

C.3. Salvo specifiche richieste da concordare prima della Conferma d'Ordine, il Venditore non garantisce che l'ordine del singolo articolo venga evaso tutto con un medesimo lotto di produzione.

## D.- TERMINI DI CONSEGNA

D.1.- I termini di consegna sono da intendersi indicativi e la proroga di essi non può far maturare all'Acquirente alcun diritto a richiedere indennizzi, ogni eccezione rimossa.

D.2.- Se, trascorsi 10 (dieci) giorni dalla data di avviso di merce pronta, l'Acquirente non ritira il materiale, il Venditore si riserva di stabilire discrezionalmente un nuovo termine di consegna.

## E.- RESA E SPEDIZIONE

E.1.- L'eventuale variazione della destinazione dei Prodotti, diversa da quella concordata in Conferma d'Ordine, deve essere comunicata dall'Acquirente per iscritto entro e non oltre il secondo giorno antecedente a quello previsto per il ritiro presso la sede del Venditore. Il Venditore si riserva la facoltà di non accettare la variazione della destinazione dei Prodotti. Nel caso si verifichi che la destinazione effettiva del Prodotto sia stata diversa da quella dichiarata dall'Acquirente, il Venditore si riserva la facoltà di sospendere l'esecuzione delle forniture in corso e/o risolvere i contratti in corso senza che l'Acquirente possa rivendicare risarcimenti diretti e/o indiretti di alcun tipo.

E.2.- Salvo patto contrario, la fornitura della merce si intende Franco Fabbrica (EXW ai sensi degli Incoterms 2010) e ciò anche quando sia convenuto che la spedizione o parte di essa venga curata dal Venditore su mandato dell'Acquirente. In ogni caso i rischi passano all'Acquirente al più tardi con la consegna al primo trasportatore.

E.3.- Ferma restando l'estraneità del Venditore rispetto al contratto di trasporto, il Venditore non potrà essere indicato come “shipper” nella polizza di carico. La comunicazione del peso lordo del container allo spedizioniere, non costituisce alcuna assunzione di responsabilità da parte del Venditore ai fini della Convenzione SOLAS (Safety Of Life At Sea). In nessun caso tale comunicazione potrà essere intesa come VGM (Verified Gross Mass).

E.4.- L'Acquirente s'impegna affinché il mezzo inviato presso i magazzini del Venditore sia idoneo al carico in relazione alla natura dei Prodotti. Nel caso il mezzo che si presenta comporti significative difficoltà per le operazioni di carico, il Venditore si riserva di addebitare una penale pari al 4% del valore dei prodotti a copertura dei maggiori costi logistici. Se il mezzo convenuto non è assolutamente idoneo, il Venditore si riserva la facoltà di negare le operazioni di carico senza che nulla possa essere richiesto dall'Acquirente a titolo di risarcimento per ogni onere diretto e/o indiretto che ne possa derivarne.

E.5.- È compito dell'Acquirente incaricare il vettore di controllare i prodotti prima del carico; eventuali osservazioni in relazione all'integrità degli imballi e della rispondenza delle quantità caricate a quelle indicate sul documento di trasporto, devono essere sollevate dal vettore al momento del carico. Tali osservazioni devono essere riportate su tutte le copie dei documenti di trasporto, altrimenti i prodotti caricati s'intendono integri e completi. Ne deriva che il Venditore non si assume alcuna responsabilità in relazione a mancanze o danni dei prodotti non segnalati dal vettore.

E.6.- È altresì responsabilità dell'Acquirente incaricare il vettore di verificare le modalità e la stabilità del carico sul mezzo affinché durante il trasporto non si verifichino rotture e affinché siano rispettate tutte le disposizioni di sicurezza riguardanti la circolazione stradale.

## F.- PAGAMENTI

F.1.- Qualsiasi obbligazione di pagamento deve essere adempiuta presso la sede legale del Venditore. Eventuali pagamenti ad agenti, rappresentanti o ausiliari di commercio non si intendono effettuati finché le relative somme non pervengono al Venditore.

F.2.- E' fatto divieto all'Acquirente di eseguire il proprio adempimento mediante pagamenti provenienti da paesi diversi dal proprio paese di residenza se trattasi di paesi che non garantiscono un adeguato scambio di informazioni con l'Italia. In caso di violazione di tale divieto, il Venditore ha facoltà di risolvere il contratto per giusta causa senza che l'Acquirente possa vantare il diritto di ottenere alcun risarcimento per l'eventuale danno subito.

F.3.- Eventuali spese di bollo ed incasso effetti e tratte sono a carico dell'Acquirente. In caso di inadempimento, anche solo parziale, dal giorno fissato per il pagamento decorreranno a favore del Venditore gli interessi moratori nella misura prevista dal d.lgs. 09/10/2002 n. 231.

F.4.- Salvo diversi accordi scritti, l'Acquirente si impegna a non compensare alcun credito, comunque insorto, nei confronti del Venditore.

## G.- RECLAMI

G.1.- Al ricevimento dei Prodotti, l'Acquirente dovrà sottoporli ad accurato controllo attraverso un esame visivo effettuato conformemente alle indicazioni riportate al punto 7 delle norme UNI EN ISO 10545-2.

G.2.- L'installazione e la posa dei Prodotti deve essere effettuata attenendosi scrupolosamente alle raccomandazioni inerenti le attività da svolgere prima e durante la posa in opera indicate nel documento 1) Manuale di Posa, Uso, Pulizia e Manutenzione pubblicato nel sito internet del Venditore e sulla confezione del prodotto e/o all'interno della stessa. Non sono considerati vizi del Prodotto quelli generati da un'errata installazione e dalla mancata/errata manutenzione (difformi dalle indicazioni fornite nel 1) Manuale di Posa, Uso, Pulizia e Manutenzione), da una non idonea destinazione d'uso e/o dalla normale usura nel tempo.

G.3.- Fatti salvi i limiti di accettabilità previsti dalla norma internazionale EN 14411 (ISO 13006), le Parti riconoscono come Vizi Palesi i difetti dei Prodotti riscontrabili già al momento del loro ricevimento tali da rendere il materiale inidoneo all'uso o da diminuirne in modo apprezzabile il valore. Rientrano in tale categoria i difetti come definiti nel documento 1) Manuale di Posa, Uso, Pulizia e Manutenzione pubblicato nel sito internet del Venditore. A titolo esemplificativo e non esaustivo si riconoscono come Vizi Palesi i difetti superficiali, i difetti di decorazione, di lappatura/levigatura, di calibro, di planarità, di ortogonalità-rettilineità, di spessore, le crepe, le sbecature, i fuori tono, i toni mescolati e i Prodotti che presentano problemi da taglio/scaglie.

G.4.- Nel caso l'Acquirente rilevi Vizi Palesi dovrà fare reclamo al Venditore per iscritto, a pena di decadenza, entro 8 (otto) giorni dal ricevimento e tenere a disposizione del Venditore l'intera partita di materiale. Il reclamo dovrà riportare i dati di fatturazione e una precisa descrizione del vizio reclamato corredata, quando possibile, da immagini fotografiche. Qualora il reclamo dovesse risultare infondato, l'Acquirente si rende disponibile a risarcire il Venditore delle spese sostenute per l'eventuale sopralluogo (perizie, viaggi, ecc).

G.5.- I Vizi Occulti dovranno essere notificati al Venditore mediante lettera raccomandata A.R., a pena di decadenza dalla garanzia, entro 8 (otto) giorni dalla data della scoperta del difetto.

G.6.- L'azione dell'Acquirente diretta a fare valere la garanzia per vizi si prescrive comunque nel termine di 12 (dodici) mesi decorrenti dalla consegna dei Prodotti.

### H.- GARANZIA PER VIZI

H.1.- La garanzia del Venditore si intende limitata ai soli Prodotti di prima scelta e non ai Prodotti di seconda o terza scelta o di partite d'occasione con prezzi o sconti particolari quando debitamente segnalati in nota nella Conferma dell'Ordine.

H.2. Il Venditore non garantisce l'idoneità dei Prodotti ad usi particolari, ma soltanto le caratteristiche tecniche pubblicate nel sito internet nel documento 2) Schede tecniche. L'indicazione d'uso, anche quando presentata dal Venditore in cataloghi e manuali, è da ritenersi puramente indicativa. Sulla base delle caratteristiche tecniche riportate nelle 2) Schede Tecniche è sempre compito del progettista valutare l'idoneità del Prodotto alle condizioni specifiche di utilizzo in funzione delle sollecitazioni e delle variabili che si possono verificare nell'ambiente di destinazione alterandone le sue caratteristiche, a titolo d'esempio, all'intensità del traffico, alla qualità del traffico (calpestio in presenza di sabbia, di detriti...), alle eventuali condizioni climatiche avverse e a qualsiasi altra aleatorietà a cui può essere esposto il materiale.

H.3.- Nel caso risulti accertato che il Prodotto manifesti Vizi Palesi, come definiti al sub lett. G n.3, il Venditore provvederà alla sostituzione del Prodotto difettoso con altro avente caratteristiche pari o superiori o nel caso ciò non sia possibile ad una congrua riduzione del prezzo. In alternativa l'Acquirente avrà diritto, previa restituzione dei Prodotti viziati, al rimborso del prezzo pagato, maggiorato del costo del trasporto, con esclusione del risarcimento di ogni altro danno diretto e/o indiretto.

H.4. La garanzia del Venditore deve ritenersi esclusa nel caso in cui il Prodotto affetto da Vizi Palesi (in tutto o in parte) sia stato utilizzato e/o comunque trasformato dovendosi ritenere che in tal modo l'Acquirente (o il suo cliente) abbia espresso la volontà di accettarli nello stato in cui si trovano.

H.5 Nel caso risulti accertato che il Prodotto manifesti Vizi Occulti, la garanzia del Venditore è limitata alla sostituzione del materiale con altro avente caratteristiche pari o superiori e ove ciò non sia possibile al rimborso del prezzo pagato maggiorato del costo del trasporto. In ogni caso la garanzia del Venditore per ogni danno diretto e/o indiretto comunque originato dal prodotto difettoso, deve intendersi limitata ad una somma che non potrà superare il doppio del prezzo di vendita applicato dal Venditore in relazione alla sola parte della fornitura difettosa.

H.6.- Nel caso l'Acquirente rivenda il Prodotto a soggetti tutelati dal codice del consumo (d.l. n.206/2005) sarà responsabile delle condizioni praticate se difformi da quelle qui riportate e dovrà accertarsi che i diritti del consumatore siano esercitati nel rispetto dei rimedi e dei termini fissati da tale codice. Nel caso sussistano i presupposti, il diritto di regresso e/o comunque di rivalsa spettanti all'Acquirente verso il Venditore/produttore non potrà eccedere le esenzioni ed i limiti come fissati dal sub lett. G n.1 al sub lett. H n.5.

### I. CLAUSOLE SOLVE ET REPETE E RISOLUTIVE

I.1.- Ai sensi dell'art. 1462 del Codice Civile, per nessun motivo, ivi compresi pretesi vizi o difetti del materiale, l'Acquirente potrà sospendere o ritardare il pagamento del materiale ritirato, salva naturalmente la facoltà di ripetere quando possa dimostrare di avere indebitamente pagato.

I.2.- Nel caso di mutamento delle condizioni patrimoniali dell'Acquirente o di mancato pagamento anche parziale di prodotti già forniti, il Venditore può sospendere l'esecuzione delle forniture in corso e/o risolvere i contratti in corso senza che l'Acquirente possa rivendicare risarcimenti diretti e/o indiretti di alcun tipo.

## L.- PATTO DI RISERVATO DOMINIO

L.1.- Fino a quando l'Acquirente non avrà provveduto all'integrale pagamento del prezzo, i Prodotti oggetto della fornitura rimarranno di proprietà del Venditore.

L.2.- Durante il periodo suddetto, l'Acquirente assumerà gli obblighi e le responsabilità del custode, e non potrà alienare, dare in uso, lasciare sequestrare o pignorare tali Prodotti senza dichiarare la proprietà del Venditore e dare immediato avviso a mezzo raccomandata A.R.

## M.- FORZA MAGGIORE

M.1.- Ciascuna parte potrà sospendere l'esecuzione dei suoi obblighi contrattuali quando tale esecuzione sia resa impossibile o oggettivamente troppo onerosa da un impedimento imprevedibile indipendente dalla sua volontà, quale ad esempio: sciopero, boicottaggio, serrata, incendio, guerra (dichiarata o non), guerra civile, sommosse e rivoluzioni, requisizioni, embargo, interruzioni di energia, rotture straordinarie di macchinari, ritardi nella consegna di componenti o materie prime.

M.2.- La parte che desidera avvalersi della presente clausola dovrà comunicare immediatamente per iscritto all'altra parte il verificarsi e la cessazione delle circostanze di forza maggiore.

M.3.- Qualora la sospensione dovuta a forza maggiore duri più di 60 (sessanta) giorni, ciascuna parte avrà il diritto di risolvere il presente contratto, previo un preavviso di 10 (dieci) giorni, da comunicarsi alla controparte per iscritto.

## N.- OBBLIGO DI RISERVATEZZA

N.1.- L'Acquirente è tenuto ad osservare la più assoluta riservatezza su tutte le notizie di carattere tecnico (quali, in via meramente esemplificativa, disegni, prospetti, documentazioni, formule e corrispondenza) e di carattere commerciale (ivi comprese le condizioni contrattuali, i prezzi d'acquisto, le condizioni di pagamento ...) apprese in esecuzione del presente Contratto.

N.2.- L'obbligo di riservatezza viene assunto per tutta la durata del Contratto, nonché per il periodo successivo alla sua esecuzione.

N.3.- In ogni caso di inosservanza dell'obbligo di riservatezza, la parte inadempiente è tenuta e risarcire all'altra tutti i danni che ne dovessero derivare.

### O.- MARCHI E SEGNI DISTINTIVI DEL VENDITORE

O.1.-L'utilizzo dei marchi, dei modelli ornamentali e delle opere d'ingegno in genere, in qualunque forma o modo di espressione (quali a titolo meramente esemplificativo, ma non esaustivo: immagini, foto, disegni, filmati, figure, strutture, etc.) costituenti proprietà intellettuale del Venditore, attraverso qualsiasi mezzo (quali a titolo meramente esemplificativo, ma non esaustivo: stampa, video, radio, internet, social media, piattaforme di messaggistica istantanea o VoIP, etc.) è severamente vietato. Qualsiasi deroga a tale divieto, anche solamente parziale, dovrà essere autorizzata per iscritto, caso per caso, dalla Direzione generale del Venditore.

### P.- LINGUA DEL CONTRATTO, LEGGE APPLICABILE, GIURISDIZIONE E COMPETENZA

P.1.- Il Contratto e le presenti condizioni sono redatti in lingua Italiana, la quale prevarrà nel caso di divergenza con la traduzione in altre lingue.

P.2.- La definizione di qualsiasi controversia comunque relativa alle forniture è soggetta alla legge ed alla giurisdizione dello Stato Italiano e la competenza territoriale viene devoluta in via esclusiva al Tribunale di Modena nella cui circoscrizione il Venditore ha la sua sede legale.

# GENERAL CONDITIONS OF SALES / Rev.1a - 1st January 2018

## A.- CONTRACT COMPLETION

- A.1.- These general sales conditions govern every sales contract between the Seller and the Buyer and any amendment or exception thereof shall be agreed in writing.
- A.2.- Any offers, credits and/or rebates granted by agents or other intermediaries, shall not be considered valid if they are not confirmed in writing by the Seller.
- A.3.- The Buyer shall send the written orders to the Seller, directly or through the agents, and the orders shall include the codes of the required products, quantity, price and destination. The order sent by the Buyer is irrevocable.
- A.4.- The sale shall be deemed completed when: (i) the Buyer receives a written confirmation from the Seller, via e-mail, fax or other electronic means, that complies with the terms and conditions of the order; or (ii) if the confirmation sent by the Seller contains conditions that differ from the order sent by the Buyer, when the latter accepts it in writing or in any case does not object within 7 (seven) days from reception; or (iii) if the Seller does not provide a written confirmation, when the products are delivered and loaded by the Buyer.

## B.- PRICES

- B.1.- The prices agreed upon for each individual sale are net prices for cash delivery ex works (the Seller’s plant shall be specified in the order confirmation), unless otherwise agreed in writing.

## C.- PRODUCT CHARACTERISTICS

- C.1.- The Buyer declares to have read and comply with the content of the following documentation published on the corporate website: 1) Laying, use, cleaning and maintenance manual and 2) Technical data sheets.
- C.2. Given the intrinsic variability of the ceramic products, the characteristics of the samples, previously sent by the Seller to the Buyer, are purely illustrative and cannot be deemed binding.
- C.3. Unless specifically requested and agreed before the order confirmation, the Seller does not guarantee that the entire quantity of an article on order shall be sent from one same production lot.

## D.- DELIVERY TERMS

- D.1.- The delivery terms are approximate and a delay does not give the Buyer any right to claim compensation, without any exception.
- D.2.- If the Buyer does not collect the goods, after 10 (ten) days from the date of the “goods ready” notice, the Seller has the right – at its discretion – to establish a new delivery date.

## E.- SHIPPING ARRANGEMENTS AND TERMS

- E.1.- The Buyer must communicate any variation in the destination of the products, different from the one agreed in the order confirmation, in writing within, and no later than, the second day before the day foreseen for the collection at the Seller’s premises. The Seller reserves the right not to accept the change of the product destination. If the actual destination of the product is different from the one stated by the Buyer, the Seller reserves the right to suspend the execution of the supplies underway and/or to terminate the contracts in force and the Buyer shall not have the right to claim direct and/or indirect compensation of any type.
- E.2.- Unless otherwise agreed, the goods shall be delivered ex-works (EXW - Incoterms 2010) and this shall also be the case when the parties agree that the delivery, or part of it, shall be arranged by the Seller on the Buyer’s behalf. In any case, the risks shall transfer to the Buyer upon delivery to the first carrier.
- E.3.- Without prejudice to the Seller’s extraneity in relation to the transport contract, the Seller shall not be indicated as “shipper” on the bill of lading. The communication of the gross weight of the container to the Forwarding agent does not represent in any way the undertaking of any liability by the Seller as regards the SOLAS (Safety Of Life At Sea) Convention. In no event may the said communication be taken to be the VGM (Verified Gross Mass).
- E.4.- The Buyer undertakes to ensure that the vehicle sent to the Seller’s warehouse is suitable for the loading operations, considering the nature of the products. If the vehicle sent to collect the goods causes difficulties in the loading operations, the Seller reserves the right to charge a penalty, of 4% of the value of the products, to cover the extra logistics costs. If the vehicle sent is not at all suitable, the Seller reserves the right to refuse to load the goods and the Buyer shall not have the right to claim compensation for any direct and/or indirect cost that may arise therefrom.
- E.5.- The Buyer is responsible for assigning the carrier the task of checking the products before loading them; any observations concerning the condition of the packaging and the correspondence of the quantities loaded with those on the transport document must be made by the carrier upon collection of the goods. The said observations must be written on all the copies of the transport documents, otherwise the loaded products shall be considered to be complete and in good condition. As a result, the Seller shall not be liable for any missing or damaged products not reported by the carrier.
- E.6.- The Buyer is also responsible for assigning the carrier the task of checking the loading procedure and the stability of the goods on the vehicle, in order to prevent damage during transport and to comply with all road safety provisions.

## F.- PAYMENTS

- F.1.- All payments must be made to the Seller’s registered office. Payments made to agents, representatives, or sales assistants shall not be considered as made until the amounts are received by the Seller.
- F.2.- The Buyer shall not fulfil its payment obligations by making payments from countries other than its own country of residence, if the said countries do not guarantee an adequate exchange of information with Italy. In case of breach of the said prohibition, the Seller has the right to terminate the contract for just cause and the Buyer shall not have the right to claim compensation for any damage suffered.
- F.3.- Any costs for stamp duty and bank draft fees shall be borne by the Buyer. Failure to fulfil, even only in part, the payment shall result in the application of interest on arrears in favour of the Seller, from the date established for the payment, as envisaged by legislative decree 09/10/2002 no. 231.
- F.4.- Unless otherwise agreed in writing, the Buyer undertakes not to offset any receivables, of whatever nature, owed by the Seller.

## G.- CLAIMS

- G.1.- Upon receipt of the products, the Buyer shall perform a visual inspection in compliance with instructions provided in point 7 of UNI EN ISO 10545-2 standards.
- G.2.- The products must be installed and fitted strictly respecting the recommendations related to the activities to be performed before and during the laying of the product specified in document 1) Laying, use, cleaning and maintenance manual, published on the Seller’s website, and on the product packaging and/or inside the packaging. Faults caused by an incorrect installation and by missing/incorrect maintenance (different from instructions provided in document 1) Laying, use, cleaning and maintenance manual), by an unsuitable use and/or by normal wear over time shall not be considered product faults.
- G.3.- With the exception of the limits of acceptability foreseen by the international EN 14411 (ISO 13006) standard, the parties acknowledge as identifiable faults those product defects that are immediately visible upon receipt thereof and that make the material unsuitable for use or that significantly reduce its value. This category includes faults as defined in the document 1) Laying, use, cleaning and maintenance manual, published on the Seller’s website. Identifiable faults include, by way of a non-limiting example, superficial defects, decoration defects, defects concerning polishing, dimensions, surface flatness, straightness of sides/rectangularity and thickness, cracks, chippings or rough edges, non-compliant shades, mixed shades and products that feature problems deriving from the cutting process and/or from chips.

- G.4.- If the Buyer finds an identifiable fault, it must be reported in writing to the Seller, within 8 (eight) days from receipt of the products; failure to send the claim shall result in the forfeiture and loss of such right. The Buyer shall keep the entire lot of material readily available for the Seller. The claim shall include the invoice details and an accurate description of the claimed fault together with photographs, where possible. In the event that the claim proves to be unfounded, the Buyer shall refund the Seller any costs incurred for an inspection (expert’s reports, travel, etc.).
- G.5.- Hidden faults shall be notified to the Supplier in writing, by recorded delivery letter with advice of receipt, within 8 days from the date such fault is found, under penalty of forfeiture.
- G.6.- The Buyer’s right to make a claim for faults under warranty is valid for 12 (twelve) months from the delivery of the products.

## H.- WARRANTY FOR FAULTS

- H.1.- The Seller’s warranty is limited to first grade products and not second or third grade products or lots on offer with special prices or discounts, which must be duly specified with a note in the order confirmation.
- H.2. The Seller does not guarantee the suitability of the products for particular uses, and only guarantees the technical specifications published on the website in the document 2) Technical data sheets. The indication for use is merely indicative, even when written in the Seller’s catalogues and manuals. On the basis of the characteristics described in the document 2) Technical data sheets, the designer always has the task of assessing the suitability of the product for the specific use conditions, taking into account the stress and variables to which the product will be subjected, which may alter its characteristics; for example, the traffic intensity, quality of traffic (foot traffic with the presence of sand, debris...), adverse weather conditions and any other unpredictable factor to which the material may be exposed.
- H.3.- In the event that identifiable product faults are ascertained, as defined in sub section G no. 3, the Seller shall replace the faulty product with another one with equal or superior characteristics; should this not be possible, the Seller shall apply a significant price reduction. Alternatively, following the return of the faulty products, the Buyer shall have the right to a refund of the price paid plus the transport cost, with the exclusion of compensation for any other direct and/or indirect damage.
- H.4. The Seller’s warranty shall not be valid if the products that have identifiable faults (totally or in part) have been used and/or in any case transformed, as this entails that the Buyer (or its customer) expressed the intention to accept them in the condition in which they were found.
- H.5.- In the event that hidden product faults are ascertained, the Seller’s warranty is limited to the replacement with other products of equal or superior characteristics; should this not be possible the Seller shall refund the price paid plus the transport cost. In any case, the Seller’s warranty for any direct and/or indirect damage caused by the faulty product, shall be limited to an amount that shall not be greater than double the selling price applied by the Seller, only in relation to the faulty part of the supply.
- H.6.- In the event that the Buyer resells the product to subjects protected by the consumer code (law decree no. 206/2005), the former shall be responsible for the conditions applied, if different from those stated herein, and shall ensure that the consumer’s rights are exercised, in relation to the remedies and terms established by the said code. If there are the grounds for the Buyer to exercise the right of recourse and/or make a claim against the Seller/manufacturer, the said action shall take into account or go beyond the exemptions and limits established in sub sections G no. 1 and H no. 5.

## I. SOLVE ET REPETE (pay and then claim) AND TERMINATION CLAUSES

- I.1.- Pursuant to article 1462 of the Italian Civil Code, on no account may the Buyer suspend or delay payment of collected material, including in the event of alleged defects or faults in the material; this does not affect the right to claim back any payments made unduly (solve et repete).
- I.2.- If the Buyer’s financial situation changes or in the event of non-payment (even partial) of products already supplied, the Seller reserves the right to suspend the execution of the supplies underway and/or to terminate the contracts in force and the Buyer shall not have the right to claim direct and/or indirect compensation of any type.

## L.- RETENTION OF OWNERSHIP

- L.1.- The products supplied shall remain exclusive property of the Seller until the Buyer has paid the full amount.
- L.2.- During the aforementioned period, the Buyer shall undertake the obligations and responsibilities as bailee (also referred to as custodian) and shall not transfer the said products, grant their use, let them be seized or distrained without declaring that the property is of the Seller, and the Buyer shall immediately inform the Seller by recorded delivery letter with advice of receipt.

## M.- FORCE MAJEURE

- M.1.- Each party may suspend the fulfilment of its contractual obligations, when the said fulfilment is impossible or objectively too costly due to an unforeseeable impediment independent from the parties, such as for example: strike, boycott, lockout, fire, war (declared or not), civil war, riots and revolutions, requisitions, embargo, power blackouts, extraordinary breakage of machinery, delays in the delivery of components or raw materials.
- M.2.- The party that wishes to apply this clause shall immediately notify the onset and end of the circumstances of force majeure to the other party in writing.
- M.3.- If the suspension due to force majeure lasts longer than 60 (sixty) days, each party shall have the right to terminate this contract, with a notice of 10 (ten) days to be notified to the counterparty in writing.

## N.- CONFIDENTIALITY

- N.1.- The Buyer undertakes to maintain confidentiality as regards all information of a technical (such as, by way of a non-limiting example, drawings, tables, documentation, formulas and correspondence) and commercial nature (including contractual conditions, purchase prices, payment conditions,...) gained during the performance of this contract.
- N.2.- The confidentiality obligation shall be undertaken for the entire duration of this contract and for the period following its execution.
- N.3.- In case of failure to uphold the confidentiality obligation, the non-fulfilling party shall pay the other party compensation for all damages that may derive therefrom.

## O.- SELLER’S TRADEMARKS AND DISTINCTIVE SIGNS

- O.1.-The use of trademarks, ornamental designs and creative works in general, in whatever form and manner of expression (such as, by way of a non-limiting example: images, photos, drawings, videos, shapes, structures, etc.) constituting the Seller’s intellectual property, through any means (such as, by way of a non-limiting example: press, video, radio, internet, social media, instant messaging platforms or VoIP, etc.) is strictly forbidden. Any exception to the said prohibition, even only partial, must be authorised in writing, each time, by the Seller’s general management.

## P.- CONTRACT LANGUAGE, APPLICABLE LAW, JURISDICTION AND AUTHORITY

- P.1.- The present CONTRACT is drafted in Italian, and in case of disputes the said version shall prevail over any translations in other languages.
- P.2.- Any dispute concerning the supply of products shall be subject to Italian law and jurisdiction and the Court of Modena, the town in which the Seller has its registered office, shall have sole local jurisdiction.

# CONDITIONS GÉNÉRALES DE VENTE / Rév.1a - 01 Janvier 2018

**A.- MODALITÉS DE CONCLUSION DU CONTRAT**

A.1.- Les présentes Conditions Générales de Vente régissent tout contrat de Vente entre le Vendeur et l'Acheteur et toute modification ou dérogation de ces dernières doit être convenue par écrit.

A.2.- D'éventuelles offres, accréditations et / ou ristournes accordées par des agents ou par d'autres intermédiaires, ne seront réputées valables que si elles sont confirmées par écrit par le Vendeur.

A.3.- L'Acheteur envoie au Vendeur, directement ou par l'intermédiaire d'agents, des Commandes écrites qui doivent indiquer les codes des Produits demandés, les quantités, leur prix et leur destination. La commande envoyée par l'Acheteur est irrévocable.

A.4.- La Vente doit être réputée conclue au moment où : (i) l'Acheteur reçoit de la part du Vendeur une Confirmation écrite par e-mail, par télécopie ou par d'autres moyens télématiques, conforme aux conditions de la Commande ; ou (ii) en cas de Confirmation envoyée par le Vendeur contenant des conditions différant de la Commande envoyée par l'Acheteur lorsque celui-ci l'accepte par écrit ou quoi qu'il en soit s'il ne la conteste pas dans un délai de 7 (sept) jours à compter de la réception ; ou (iii) en l'absence d'une confirmation écrite de la part du Vendeur, au moment où les Produits seront livrés et chargés par l'Acheteur.

**B.- PRIX**

B.1.- Sauf accord contraire, les prix de vente convenus au fur et à mesure sont réputés nets, pour les paiements en espèces et les livraisons Franco l'établissement du Vendeur indiqué sur la Confirmation de Commande.

**C.- CARACTÉRISTIQUES DES PRODUITS**

C.1.- L'Acheteur déclare avoir lu et s'en tenir au contenu de la documentation suivante publiée sur le site Internet de la société: 1) Manuel de Pose, d'Utilisation, de Nettoyage et d'Entretien et 2) Fiches techniques.

C.2. Vu la variabilité intrinsèque du produit en céramique, les caractéristiques des échantillons et / ou des modèles envoyés précédemment par le Vendeur à l'Acheteur sont indicatifs et non contraignants.

C.3. Sauf en cas de demandes spécifiques à convenir avant la Confirmation de Commande, le Vendeur ne garantit pas la commande d'un article soit intégralement constituée par un même lot de production.

**D.- DÉLAIS DE LIVRAISON**

D.1.- Les délais de livraison s'entendent fournis à titre indicatif et leur prorogation ne donne en aucun cas le droit à l'Acheteur de demander des indemnisations, excluant dès à présent toute exception.

D.2.- Si l'Acheteur ne retire pas le matériel, au bout d'un délai de 10 (dix) jours à compter de la date de l'annonce indiquant que la marchandise est prête, le Vendeur se réserve la faculté de fixer à sa discrétion un nouveau délai de livraison.

**E.- LIVRAISON ET EXPÉDITION**

E.1.- L'éventuelle variation de la destination des Produits, différente de celle convenue dans la Confirmation de Commande, doit être communiquée par l'Acheteur par écrit au plus tard le second jour qui précède le jour du retrait au siège du Vendeur. Le Vendeur se réserve la faculté de ne pas accepter la variation de la destination des Produits. Au cas où la destination effective du Produit serait différente de celle déclarée par l'Acheteur, le Vendeur se réserve la faculté de suspendre l'exécution des fournitures en cours et / ou de résilier le contrat sans que l'Acheteur puisse revendiquer des indemnisations directes et / ou indirectes d'aucune sorte.

E.2.- Sauf accord contraire, la fourniture de la marchandise est livrée Départ Usine (EXW aux termes des Incoterms 2010) même si l'on a convenu que l'expédition ou une partie de cette dernière sera suivie par le Vendeur sur mandat de l'Acheteur. En tout état de cause, les risques passent à l'Acheteur au plus tard au moment de la livraison au premier transporteur.

E.3.- Sans préjudice du désintérêt du Vendeur par rapport au contrat de transport, celui-ci ne pourra être indiqué comme le “shipper” dans le connaissance. La communication du poids brut du container à l'expéditeur, ne constitue pas une prise de responsabilité de la part du Vendeur aux fins de la Convention SOLAS (Safety Of Life At Sea). En aucun cas cette communication ne pourra être considérée comme le VGM (Verified Gross Mass).

E.4.- L'Acheteur s'engage à ce que le véhicule envoyé aux entrepôts du Vendeur soit compatible avec la nature des Produits à charger. Si le véhicule qui se présente comporte des difficultés significatives pour les opérations de chargement, le Vendeur se réserve la faculté de débiter une pénalité de l'ordre de 4 % de la valeur des produits pour couvrir les coûts logistiques supplémentaires. Si le véhicule convenu n'est absolument pas compatible, le Vendeur se réserve la faculté de refuser les opérations de chargement sans que l'Acheteur ne puisse rien lui demander à titre de remboursement de toute dépense directe et / ou indirecte éventuelle.

E.5.- Il appartient à l'Acheteur de charger le transporteur de contrôler les produits avant le chargement ; d'éventuelles observations concernant l'intégrité des emballages et la correspondance des quantités chargées avec celles indiquées sur le document de transport doivent être soulevées par le transporteur au moment du chargement. Ces observations doivent être indiquées sur toutes les copies des documents de transport ; dans le cas contraire, les produits chargés sont réputés intacts et complets. Il s'ensuit que le Vendeur décline toute responsabilité en cas d'absence ou de détérioration des produits non signalée par le transporteur.

E.6.- L'Acheteur a également la responsabilité de charger le transporteur de vérifier les modalités et la stabilité du chargement sur le véhicule afin d'éviter les bris durant le transport et le respect de toutes les dispositions de sécurité concernant la circulation sur route.

**F.- PAIEMENTS**

F.1.- Toute obligation de paiement doit être accomplie au siège légal du Vendeur. Les éventuels paiements remis à des agents, à des représentants ou à des auxiliaires de commerce ne seront réputés effectués qu'au moment où le Vendeur percevra les sommes correspondantes.

F.2.- Il est interdit à l'Acheteur d'effectuer des paiements depuis un pays différent de son pays de résidence et ne garantissant pas un échange d'informations correct avec l'Italie. En cas de violation de cette interdiction, le Vendeur a la faculté de résilier le contrat pour juste cause sans que l'Acheteur ne puisse revendiquer le droit d'obtenir une quelconque réparation pour l'éventuel préjudice subi.

F.3.- Les éventuels frais de timbre et d'encaissement d'effets et de traites sont à la charge de l'Acheteur. En cas de défaillance, même partielle, des intérêts de retard commencent à courir en faveur du Vendeur, à compter du jour fixé pour le paiement, dans la mesure prévue par le Décret Législatif italien n° 231 du 09/10/2002.

F.4.- Sauf accord écrit contraire, l'Acheteur s'engage à ne compenser aucune créance échue.

**G.- RÉCLAMATIONS**

G.1.- À la réception des Produits, l'Acheteur devra soumettre ces derniers à un contrôle minutieux moyennant un examen visuel effectué conformément aux indications du point 7 des normes UNI EN ISO 10545-2.

G.2.- L'installation et la pose des Produits doivent être effectuées en suivant scrupuleusement les recommandations inhérentes aux activités exercées avant et durant la pose indiquées sur le document 1) Manuel de Pose, d'Utilisation, de Nettoyage et d'Entretien, publié sur le site Internet du Vendeur ainsi qu'à l'extérieur et/ou à l'intérieur de l'emballage du produit. Les défauts dus à une installation erronée et à un entretien absent / erroné (ne respectant pas les indications fournies dans le 1) Manuel de Pose, d'Utilisation, de Nettoyage et d'Entretien), par un usage prévu inapproprié et / ou par l'usure normale due au temps ne sont pas considérés comme des vices du Produit.

G.3.- Sous réserve des limites d'acceptabilité prévues par la norme internationale EN 14411 (ISO 13006), les Parties reconnaissent comme des Vices Évidents les défauts des Produits existant dès la réception de sorte que le matériel devienne inutilisable ou qu'il perde une grande partie de sa valeur. Cette catégorie comprend les défauts définis dans le document 1) Manuel de Pose, d'Utilisation, de Nettoyage et d'Entretien publié sur le site Internet du Vendeur. À titre d'exemple non contraignant, on reconnaît comme des Vices Évidents les défauts de surface, de décoration, de polissage, de calibre,

de planéité, d'orthogonalité–rectitude, d'épaisseur, les fissures, les ébréchés, les hors nuance, les nuances mélangées et les Produits qui présentent des problèmes de coupe - voile.

G.4.- Si l'Acheteur relève des Vices Évidents, il devra présenter une réclamation écrite au Vendeur, sous peine de déchéance, dans un délai de 8 (huit) jours à compter de la réception et tenir le lot complet de matériel à la disposition de ce dernier. La réclamation devra indiquer les données de facturation et une description précise du vice objet de la réclamation, accompagnée, si possible, de photographies. Si la réclamation devait s'avérer sans fondement, l'Acheteur est disposé à rembourser au Vendeur les dépenses encourues pour l'éventuelle visite des lieux (expertises, déplacements, etc.).

G.5.- Les Vices Cachés devront être notifiés au Vendeur par lettre recommandée avec avis de réception, sous peine d'annulation de la garantie, dans un délai de 8 (huit) jours à compter de la date de la découverte du défaut.

G.6.- L'action de l'Acheteur ayant pour but de faire valoir la garantie en cas de vices se prescrit dans un délai de 12 (douze) mois à compter de la livraison des Produits.

**H.- GARANTIE COUVRANT LES VICES**

H.1. La garantie du Vendeur est réputée limitée aux seuls Produits de premier choix et non aux Produits de second ou de troisième choix ou à des lots d'occasion auquel on applique des prix ou des remises particuliers lorsqu'ils sont dûment signalés dans les notes de la Confirmation de Commande.

H.2. Le Vendeur ne garantit pas l'adéquation des Produits à des usages particuliers, mais uniquement les caractéristiques techniques publiées sur le site Internet dans le document 2) Fiches techniques. L'usage indiqué, également lorsqu'il est présenté par le Vendeur dans des catalogues et des manuels, est purement indicatif. Sur la base des caractéristiques techniques indiquées dans les 2) Fiches Techniques, le concepteur a toujours le devoir d'évaluer l'adéquation du Produit aux conditions spécifiques d'utilisation en fonction des contraintes et des variables pouvant se vérifier dans le lieu de destination et susceptibles d'en altérer les caractéristiques, par exemple, l'intensité et la qualité de la circulation (piètement en présence de sable, de détritrus...), ainsi que les éventuelles conditions climatiques défavorables et toute autre incidence à laquelle peut être exposé le matériel.

H.3.- Si l'on a constaté que le Produit présente les Vices Évidents définis à la lettre G n°3, le Vendeur remplacera le Produit défectueux par un autre produit ayant des caractéristiques analogues ou supérieures ou, lorsque cela est impossible, à une réduction cohérente du prix. En alternative, l'Acheteur aura droit, après la restitution des Produits défectueux, au remboursement du prix payé, majoré du prix du transport, à l'exclusion du remboursement de tout autre préjudice direct et / ou indirect.

H.4. La garantie du Vendeur doit être réputée exclue au cas où le Produit présentant des Vices Évidents (entièrement ou partiellement) aurait été utilisé et / ou du moins transformé ; dans ce cas, on considérera que l'Acheteur (ou son client) a exprimé la volonté de les accepter en l'état.

H.5 Si l'on a constaté que le Produit présente des Vices Cachés, la garantie du Vendeur se limite au remplacement du matériel par du matériel ayant des caractéristiques analogues ou supérieures et, lorsque cela est impossible, au remboursement du prix payé majoré des frais de transport. En tout état de cause, la garantie du Vendeur couvrant tout dommage direct et / ou indirect causé par le produit défectueux, se limitera à une somme qui ne pourra pas dépasser le double du prix de vente appliqué par le Vendeur dans le cadre de la seule partie de la fourniture défectueuse.

H.6.- Si l'Acheteur revend le Produit à des clients protégés par le code de la consommation (Décret–loi italien n° 206/2005) il sera responsable des conditions appliquées si celles-ci diffèrent des conditions indiquées ici et il devra s'assurer que les droits du consommateur sont exercés dans le respect des remèdes et des délais fixés par ce code. Si les conditions sont réunies, le droit de retrait et / ou de recours revenant à l'Acheteur à l'encontre du Vendeur / fabricant ne pourra dépasser ni les exonérations ni les limites établies de la lettre G n°1 à la lettre H n°5.

**I. CLAUSES SOLVE ET REPETE ET CLAUSES RÉSOLUTOIRES**

I.1.- Aux termes de l'art. 1462 du Code Civil italien, en aucun cas, y compris les prétendus vices ou défauts du matériel, l'Acheteur ne pourra suspendre ou retarder le paiement du matériel retiré, sans préjudice naturellement de la faculté d'exiger lorsqu'il est en mesure de démontrer avoir indûment payé.

I.1.- En cas de variation des conditions patrimoniales de l'Acheteur ou de non-paiement même partiel de produits déjà fournis, le Vendeur se réserve la faculté de suspendre l'exécution des fournitures en cours et / ou de résilier les contrats sans que l'Acheteur ne puisse revendiquer des indemnisations directes et / ou indirectes d'aucune sorte.

**L.- PACTE DE RÉSERVE DE PROPRIÉTÉ**

L.1.- Tant que l'Acheteur n'aura pas intégralement payé le prix, les Produits objet de la fourniture resteront la propriété du Vendeur.

L.2.- Au cours de la susdite période, l'Acheteur assumera les obligations et les responsabilités de gardien, et il ne pourra ni aliéner, ni confier, ni permettre la saisie desdits Produits sans déclarer la propriété du Vendeur et informer immédiatement ce dernier par lettre recommandée avec avis de réception.

**M.- FORCE MAJEURE**

M.1.- Chacune des parties pourra suspendre l'accomplissement de ses obligations contractuelles lorsque cette exécution est rendue impossible ou objectivement trop onéreuse par un empêchement imprévisible indépendant de sa volonté comme : les grèves, les boycottages, les lock-outs, les incendies, les guerres (déclarées ou non), les guerres civiles, les révoltes et les révolutions, les réquisitions, les embargos, les coupures de courant, les ruptures exceptionnelles de machines, les retards de livraison de composants ou de matières premières.

M.2.- La partie qui souhaite user de la présente clause devra communiquer immédiatement par écrit à l'autre partie la survenue et la cessation des circonstances de force majeure.

M.3.- Si la suspension due à une force majeure dure plus de 60 (soixante) jours, chacune des parties aura le droit de résilier le présent contrat, avec un préavis de 10 (dix) jours, en le communiquant par écrit à la partie adverse.

**N.- OBLIGATIONS DE CONFIDENTIALITÉ**

N.1.- L'Acheteur est tenu d'observer le secret le plus absolu concernant toutes les informations de caractère technique (comme, par exemple, les dessins, les notices, les documentations, les formules et la correspondance) et de caractère commercial (y compris les conditions contractuelles, les prix d'achat, les conditions de paiement, etc.) dont il aurait eu connaissance durant l'exécution du présent Contrat.

N.2.- L'obligation de confidentialité est assumée pendant toute la durée du Contrat, ainsi que pour la période successive à son exécution.

N.3.- Dans tous cas de non-observation de l'obligation de confidentialité, la partie défaillante est tenue de réparer à l'autre partie tous les éventuels préjudices.

**O.- MARQUES ET SIGNES DISTINCTIFS DU VENDEUR**

O.1.- L'utilisation des marques, des modèles ornementaux et des œuvres de l'esprit en général, sous quelque forme ou suivant quelque modalité d'expression que ce soit (à titre d'exemple, non contraignant : les images, les photos, les dessins, les vidéos, les figures, les structures, etc.) constituant la propriété intellectuelle du Vendeur, à travers tout moyen (à titre d'exemple non contraignant : l'impression, la vidéo, la radio, Internet, les médias sociaux, les plates-formes de messagerie instantanée ou VoIP, etc.) est formellement interdite. Toute dérogation à cette interdiction, même partielle, devra être autorisée par écrit, cas par cas, par la Direction générale du Vendeur.

**P.- LANGUE DU CONTRAT, LOI APPLICABLE, JURIDICTION ET COMPÉTENCE**

P.1.- Le Contrat et les présentes conditions sont rédigés en langue italienne qui prévaudra en cas de divergence avec la traduction dans d'autres langues.

P.2.- La définition de toute controverse relative aux fournitures est régie par la loi et la juridiction de l'État italien et les parties reconnaissent la compétence territoriale exclusive du Tribunal de Modène dans la circonscription duquel se trouve le siège légal du Vendeur.

# ALLGEMEINE VERKAUFSBEDINGUNGEN / Fassung.1a - 01 Januar 2018

#### A.- MODALITÄT DES VERTRAGSABSCHLUSSES

A.1.- Die vorliegenden Allgemeinen Verkaufsbedingungen regeln alle Verträge zwischen dem Verkäufer und dem Käufer und alle Änderungen oder Abweichungen davon müssen schriftlich vereinbart werden.

A.2.- Eventuelle Angebote sowie mit Handelsvertretern oder sonstigen Vermittlern vereinbarten Gutschriften sind nicht verbindlich, es sei denn, sie werden vom Verkäufer schriftlich bestätigt.

A.3.- Der Käufer sendet dem Verkäufer direkt oder über Handelsvertreter schriftliche Bestellungen zu, die die Angabe der Artikelnummern der gewünschten Produkte, der Mengen, ihres Preises und der Bestimmung enthalten müssen. Die vom Käufer gesendete Bestellung ist unwiderruflich.

A.4.- Der Verkauf gilt zu dem Zeitpunkt als abgeschlossen, an dem: (i) der Käufer vom Verkäufer eine schriftliche Bestätigung per E-Mal, Fax oder auf sonstigem Weg erhält, die den Fristen und Bedingungen der Bestellung entspricht; oder (ii) falls die vom Verkäufer gesendete Bestätigung, Bedingungen enthält, die von der vom Käufer erhaltenen Bestellung abweichen, wenn dieser diese akzeptiert oder nicht innerhalb von 7 (sieben) Tagen ab ihrem Empfang beanstandet; oder (iii) falls keine schriftliche Bestätigung durch den Verkäufer erfolgt, zu dem Zeitpunkt, an dem die Produkte geliefert und vom Käufer übernommen werden.

#### B.- PREISE

B.1.- Vorbehaltlich abweichender schriftlicher Vereinbarungen gelten die von Mal zu Mal vereinbarten Verkaufspreise als Nettobarpreise bar mit Lieferung frei ab dem in der Auftragsbestätigung angegebenen Werk des Verkäufers.

#### C.- EIGENSCHAFTEN DER PRODUKTE

C.1.- Der Käufer erklärt, die folgende auf der Web-Site des Unternehmen veröffentlichte Dokumentation zur Kenntnis genommen zu haben und sich an deren Inhalt zu halten: 1) Handbuch zur Verlegung, Benutzung, Reinigung und Pflege, und 2) Technische Datenblätter.

C.2.- Aufgrund der intrinsischen Variabilität des Keramikprodukts sind die Eigenschaften der vorausgehend vom Verkäufer an den Käufer gesendeten Warenmuster und/oder Modelle hinweisend und unverbindlich.

C.3. Vorbehaltlich spezifischer Vereinbarungen vor der Auftragsbestätigung garantiert der Verkäufer nicht, dass die Lieferung des einzelnen Artikels vollständig mit dem gleichen Produktionslos ausgeführt wird.

#### D.- LIEFERFRISTEN

D.1.- Die Lieferfristen sind unverbindlich und Verzögerungen führen für den Käufer in keinem Fall zum Anspruch auf Schadensvergütung.

D.2.- Falls der Käufer das Material nicht innerhalb von 10 (zehn) Tagen ab dem Datum der Bereitstellung der Waren abholt, behält sich der Verkäufer das Recht vor, eine neue Lieferfrist festzusetzen.

#### E.- RÜCKLIEFERUNG UND VERSAND

E.1.- Die eventuelle Änderung des Bestimmungsortes der Produkte, die sich von der in der Auftragsbestätigung vereinbarten unterscheidet, muss vom Käufer schriftlich innerhalb des zweiten Tags vor dem für die Abholung am Sitz des Verkäufers vorgesehenen mitgeteilt werden. Der Verkäufer behält sich das Recht vor, die Änderung der Bestimmung der Produkte nicht zu akzeptieren. Falls sich herausstellt, dass die effektive Bestimmung des Produkts von der vom Käufer angegebenen verschieden ist, behält sich der Verkäufer das Recht vor, die laufenden Lieferungen nicht auszuführen und/ oder die laufenden Verträge aufzulösen, ohne dass der Käufer jeglichen Anspruch auf Entscheidung geltend machen kann.

E.2.- Vorbehaltlich abweichender Vereinbarungen erfolgt die Lieferung der Ware frei ab Werk (EXW gemäß den Incoterms 2010), und dies auch, falls vereinbart wird, dass der Versand oder ein Teil desselben im Auftrag des Käufers durch den Verkäufer erfolgt. In jedem Fall gehen die Risiken spätestens mit der Übergabe an das erste Transportunternehmen an den Käufer über.

E.3.- Unter Beibehaltung der Nichtbeteiligung des Verkäufers am Transportvertrag kann der Verkäufer in der Police der Ladung als „Shipper“ angegeben werden. Die Mitteilung des Bruttogewichts des Containers an den Transportunternehmer stellt keine Übernahme der Verantwortung des Verkäufers hinsichtlich der SOLAS-Konvention dar (Safety Of Life At Sea). In keinem Fall kann diese Mitteilung als VGM (Verified Gross Mass) verstanden werden.

E.4.- Der Käufer verpflichtet sich sicherzustellen, dass das zu den Lagern des Verkäufers gesendete Fahrzeug unter Berücksichtigung der Natur der Produkte für das Laden geeignet ist. Falls das zum Laden gesendete Fahrzeug größere Probleme beim Beladen bereitet, behält der Verkäufer sich das Recht vor, zur Abdeckung der höheren Logistikkosten eine Vertragsstrafe in Höhe von 4 % des Werts der Produkte zu erheben. Falls das Fahrzeug vollkommen ungeeignet ist, behält sich der Verkäufer das Recht vor, das Verladen zu verweigern, ohne dass der Käufer einen Anspruch auf Vergütung der Schäden geltend machen kann, die direkt und/oder indirekt daraus entstehen können.

E.5.- Es ist Aufgabe des Käufers, das Transportunternehmen zu beauftragen und die Produkte vor dem Laden zu kontrollieren; eventuelle Anmerkungen zur Unversehrtheit der Verpackungen und der Übereinstimmung der geladenen Menge mit der in den Transportpapieren angegebenen müssen vom Transportunternehmen zum Zeitpunkt des Ladens vorgenommen werden. Diese Anmerkungen müssen auf alle Exemplaren der Transportpapiere vermerkt werden, anderenfalls gelten die geladenen Produkte als unbeschädigt und vollständig. Daraus folgt, dass der Verkäufer keinerlei Haftung für Fehlmengen oder Beschädigungen der Produkte übernimmt, die vom Transportunternehmen nicht gemeldet werden.

E.6.- Es ist ebenfalls Aufgabe des Käufers, das Transportunternehmen zu beauftragen und die Modalität und die Stabilität des Ladens auf das Fahrzeug zu überprüfen, damit es während des Transports nicht zu Brüchen kommt, sowie die Einhaltung der Sicherheitsbestimmungen der Straßenverkehrsordnung zu gewährleisten.

#### F.- ZAHLUNGEN

F.1.- Alle Zahlungsverpflichtung müssen am Firmensitz des Verkäufers erfüllt werden. Eventuelle Zahlungen an Handelsvertreter oder Außendienstmitarbeiter gelten als nicht geleistet, bis sie beim Verkäufer eingehen.

F.2.- Es ist dem Käufer untersagt, die Zahlungen aus Ländern vorzunehmen, die vom Land seines Firmensitzes verschieden sind, falls diese Länder keinen angemessenen Informationsaustausch mit Italien gewährleisten. Im Fall der Verletzung dieses Verbots hat der Verkäufer das Recht, den Vertrag aus gutem Grund aufzulösen, ohne dass der Käufer eine Vergütung des entstandenen Schadens geltend machen kann.

F.3.- Eventuelle Kosten und Gebühren für die Einziehung von Effekten und Wechseln gehen zu Lasten des Käufers. Im Fall der Nichteinhaltung des für die Zahlung festgesetzten Tags - auch nur partiell - fallen Säumniszinsen zu Gunsten des Verkäufers an, in der vom ital. Gesetzerlass vom 9. Oktober 2002, Nr. 231 vorgesehenen Höhe.

F.4.- Vorbehaltlich abweichender schriftlicher Vereinbarungen verpflichtet sich der Käufer, keine Guthaben gegenüber dem Verkäufer zu verrechnen.

#### G.- BEANSTANDUNGEN

G.1.- Beim Empfang der Produkte muss der Käufer sie einer sorgfältigen Sichtkontrolle gemäß den Angaben von Punkt 7 der Normen UNI EN ISO 10545-2 unterziehen.

G.2.- Die Installation und die Verlegung der Produkte müssen unter Einhaltung der Empfehlungen zu den Arbeiten ausgeführt werden, die vor und während der Verlegung ausgeführt werden müssen, wie angegeben im Dokument 1) Handbuch zur Verlegung, Verwendung, Reinigung und Pflege, veröffentlicht auf der Web-Site des Verkäufers und angegeben auf der Verpackung des Produkts und/oder im Inneren derselben. Schäden, die durch eine falsche Installation, Verlegung und durch eine unterlassene/falsche Pflege (abweichend von den Angaben in 1) Handbuch zur Verlegung, Reinigung und Wartung), durch eine ungeeignete Gebrauchsbestimmung oder durch normale Abnutzung verursacht werden, werden nicht als Mängel des Produkts anerkannt.

G.3.- Vorbehaltlich der Grenzen der Akzeptabilität, die von der internationalen Norm EN 14411 (ISO 13006) vorgesehen sind, erkennen die Parteien Mängel der Produkte als offensichtliche Mängel an, die bereits bei ihrem Empfang festgestellt werden können, die das Material zur Verwendung ungeeignet machen oder die den Wert beträchtlich verringern. In diese Kategorie fallen Mängel, wie im Dokument definiert 1) Handbuch zur Verlegung, Benutzung, Reinigung und Pflege, veröffentlicht auf der Web-Site des Verkäufers. Als nicht erschöpfende Beispiele werden Oberflächenmängel, fehlerhafte Grafik, Defekte polierte Oberfläche, Defekte des Kalibers, der Planarität, der Rechtwinkligkeit/Gradlinigkeit, der Stärke, Risse, abgeschlagene Kanten, Fehlfarbe, gemischte Brandfarbe sowie Produkte mit Kantsplitterung durch Rettifizierung als offensichtliche Mängel anerkannt.

G.4.- Falls der Käufer offensichtliche Mängel feststellt, muss er dies dem Verkäufer innerhalb von 8 (acht) Tagen ab dem Empfang schriftlich melden und die gesamte Charge des Materials für den Verkäufer zur Verfügung halten; anderenfalls verfällt der Rechtsanspruch. Bei der Beanstandung müssen die Daten der Rechnung sowie eine präzise Beschreibung des beanstandeten Mangels angegeben werden, falls möglich mit einer fotografischen Dokumentation. Falls die Beanstandung unberechtigt sein sollte, ist der Käufer gehalten, dem Verkäufer die für einen eventuellen Ortstermin aufgewendeten Kosten (Gutachten, Reisekosten, usw.) zu erstatten.

G.5.- Versendete Mängel müssen dem Verkäufer innerhalb von 8 (acht) Tagen ab Feststellung des Mangels per Einschreiben mit Rückschein gemeldet werden; anderenfalls verfällt der Rechtsanspruch.

G.6.- Die Aktion des Käufers zur Inanspruchnahme der Mängelhaftung muss in jedem Fall innerhalb von 12 (zwölf) Monaten ab der Lieferung der Produkte erfolgen.

#### H.- MÄNGELHAFTUNG

H.1.- Die Garantie des Verkäufers ist begrenzt auf Produkte erster Qualität und sie bezieht sich nicht auf Produkte zweiter oder dritter Qualität oder auf gelegentliche Partien mit besonderen Preisen oder Nachlässe, die in der Auftragsbestätigung angegeben werden.

H.2.- Der Verkäufer garantiert nicht die Eignung der Produkte für besondere Verwendungen, sondern lediglich die technischen Eigenschaften, die auf der Web-Site in Dokument 2) Technische Datenblätter veröffentlicht sind. Die Angabe zur Verwendung ist als unverbindlich anzusehen, auch wenn vom Verkäufer in Katalogen und Handbüchern angegeben ist. Es ist stets Aufgabe des Planers, auf der Grundlage der in den 2) Technischen Datenblättern angegebenen Eigenschaften die Eignung des Produkts für spezifische Nutzungsbedingungen zu bewerten, unter Berücksichtigung der Belastungen sowie der Variablen, die am Ort der Bestimmung auftreten und die Eigenschaften verändern können, wie zum Beispiel die Intensität des Verkehrs, die Qualität des Verkehrs (Begehung bei Vorhandensein von Sand, Schmutz usw.), die eventuellen klimatischen Bedingungen sowie alle sonstigen Einflüsse, denen das Material ausgesetzt sein kann.

H.3.- Falls festgestellt wird, dass das Produkt offensichtliche Mängel aufweist, wie definiert in Punkt G, Nr.3, nimmt der Verkäufer die Ersetzung des mangelhaften Produkts durch ein anderes mit gleichen oder höherwertigen Eigenschaften vor, oder er nimmt eine angemessene Reduzierung des Preises vor, falls dies nicht möglich ist. Alternativ hat der Käufer nach Rücklieferung der mangelhaften Produkte das Recht auf Rückerstattung des bezahlten Preises, zuzüglich der Transportkosten, mit Ausschließung der Vergütung aller direkten und/oder indirekten Schäden.

H.4. Die Garantie des Verkäufer wird ausgeschlossen, falls das mangelhafte Produkt (ganz oder teilweise) verwendet und/oder umgewandelt worden ist, da davon ausgegangen wird, dass der Käufer (oder sein Kunde) dadurch seinen Willen zum Ausdruck gebracht hat, es in dem Zustand zu akzeptieren, in dem es sich befindet.

H.5 Falls festgestellt wird, dass das Produkt versteckte Mängel aufweist, ist die Garantie des Verkäufers auf die Ersetzung des Materials durch anderes mit gleichen oder höherwertigeren Eigenschaften beschränkt oder - falls dies nicht möglich ist - auf die Rückerstattung des bezahlten Preises, zuzüglich der Transportkosten. In jedem Fall ist die Garantie des Verkäufers für alle direkten und/oder indirekten Schäden, die durch das mangelhafte Produkt entstehen, auf einen Betrag begrenzt, der das Doppelte des Verkaufspreises nicht übersteigen kann, den der Verkäufer auf den mangelhaften Teil der Lieferung angewendet hat.

H.6.- Falls der Käufer das Produkt an Kunden weiterverkauft, die vom Verbraucherschutzgesetz (ital. Gesetzerlass Nr. 206/2005) geschützt werden, ist er verantwortlich für die angewendeten Bedingungen, falls diese von den hier angegebenen abweichen, und er muss sicherstellen, dass die Rechte des Verbrauchers gemäß den Bestimmungen dieses Gesetzes ausgeübt werden können. Falls die Voraussetzungen gegeben sind, kann das Regressrecht des Käufers gegenüber dem Verkäufer/Hersteller nicht die Grenzen übersteigen, die von Punkt G, Nr. 1 bis Punkt H, Nr. 5 angegeben werden.

#### I. KLAUSEL SOLVE ET REPETE UND AUFLÖSUNGSKLAUSEL

I.1.- Gemäß den Bestimmungen von § 1462 des ital. Bürgerlichen Gesetzbuches kann der Käufer in keinem Fall - einschließlich von vermeintlichen Mängeln oder Defekten des Materials - die Zahlung des abgenommenen Materials aussetzen oder verzögern, natürlich vorbehaltlich des Rechts, ungerechtfertigt gezahlte Beträge zurückzufordern, und dies nur nach Erbringung des Nachweises der Rechtmäßigkeit der Forderung (Solve et Repete).

I.2.- Im Fall der Veränderung der Vermögensbedingungen des Käufers oder der auch nur partiellen Nichtbezahlung der bereits gelieferten Produkte kann der Verkäufer die laufenden Lieferungen aussetzen und/oder die laufenden Verträge auflösen, ohne dass der Käufer die Vergütung von direkten und/oder indirekten Schäden geltend machen kann.

#### L.- EIGENTUMSVORBEHALT

L.1.- Bis zur vollständigen Bezahlung des Preises durch den Käufer bleiben die Produkte, die den Gegenstand der Lieferung darstellen, Eigentum des Verkäufers.

L.2.- Während dieses Zeitraums übernimmt der Käufer die Pflichten und die Verantwortlichkeiten für die Aufbewahrung der gekauften Produkte und er kann sie nicht veräußern, zur Nutzung überlassen oder beschlagnahmen oder pfänden lassen, ohne das Eigentum des Verkäufers anzugeben und ohne diesen umgehend per Einschreiben mit Rückschein zu benachrichtigen.

#### M.- HÖHERE GEWALT

M.1.- Beide Parteien können die Ausführung der vertraglichen Pflichten aussetzen, wenn die Ausführung aus Gründen, die vom eigenen Willen unabhängig sind, unmöglich oder objektiv zu aufwendig wird, wie zum Beispiel: Streiks, Boykott, Aussperrung, Brand, Krieg (erklärt oder nicht), Bürgerkrieg, Aufstände und Revolutionen, Beschlagnahme, Embargo, Unterbrechungen der Energieversorgung, außerordentliche Defekte von Maschinen, Verspätung bei der Anlieferung von Komponenten und Rohstoffen.

M.2.- Die Partei, die beabsichtigt, die vorliegende Klausel in Anspruch zu nehmen, muss der anderen Partei schriftlich das Auftreten von Umständen der Höheren Gewalt mitteilen.

M.3.- Falls die Aussetzung aufgrund von Höherer Gewalt mehr als 60 (sechzig) Tage andauert, haben beiden Parteien das Recht, den vorliegenden Vertrag nach einer schriftlichen Vorankündigung von 10 (zehn) Tagen an die Gegenpartei aufzulösen.

#### N.- VERTRAULICHKEITSPFLICHT

N.1.- Der Käufer ist gehalten, über alle technischen Informationen (wie zum Beispiel Zeichnungen, Prospekte, Dokumentationen, Formeln und Schriftverkehr) und kommerziellen Informationen (einschließlich der Vertragsbedingungen, der Kaufpreise, der Zahlungsbedingungen usw.), in deren Kenntnis während der Ausführung des vorliegenden Vertrages kommt, absolute Vertraulichkeit einzuhalten.

N.2.- Die Vertraulichkeitspflicht wird für die Dauer des Vertrages sowie den Zeitraum nach seiner Ausführung übernommen.

N.3.- Im Fall der Nichteinhaltung der Vertraulichkeitspflicht ist die nicht einhaltende Partei gehalten, der anderen Partei alle daraus entstehenden Schäden zu vergüten.

#### O.- MARKEN UND KENNZEICHNUNGEN DES VERKÄUFERS

O.1.-Die Verwendung von Marken, Ziermotiven und geistigem Eigentum im Allgemeinen in jeder Form sowie jeder Ausdrucksform (als nicht erschöpfendes Beispiel: Bilder, Fotos, Zeichnungen, Filme, Abbildungen, Strukturen usw.), die intellektuelles Eigentum des Verkäufers sind, ist auf jede Weise (als nicht erschöpfendes Beispiel: Presse, Video, Radio, Internet, Social Media, Instant-Message-Plattform oder VoIP usw) strengstens untersagt. Alle - auch nur partielle - Abweichungen von diesem Verbot müssen von Fall zu Fall schriftlich von der Generaldirektion des Verkäufers autorisiert werden.

#### P.- SPRACHE DES VERTRAGS, ANWENDBARES RECHT, RECHTSPRECHUNG UND GERICHTSSTAND

P.1.- Der Vertrag und die vorliegenden Bedingungen werden in italienischer Sprache verfasst, die im Fall der Abweichung der Übersetzung in andere Sprachen Vorrang hat.

P.2.- Die Regelung aller Rechtssachen hinsichtlich den Lieferungen unterliegt der Rechtsprechung des italienischen Staats und die territoriale Zuständigkeit liegt ausschließlich beim Bezirksgericht Modena, dem Ort des Firmensitzes des Verkäufers.

## CONDICIONES GENERALES DE VENTA / Rev.1a de 1 de Enero 2018

#### A.- MODALIDADES DE CELEBRACIÓN DEL CONTRATO

A.1.- Las presentes Condiciones Generales de Venta disciplinan todo contrato de venta entre el Vendedor y el Comprador y toda modificación o cancelación debe ser establecida por escrito.

A.2.- Eventuales ofertas, acreditaciones y/o descuentos otorgados por agentes u otros intermediarios, no son considerados válidos mientras no sean confirmados por escrito por el Vendedor.

A.3.- El Comprador envía al Vendedor, directamente o a través de agentes, pedidos por escrito que deben contener la indicación de los códigos de los productos requeridos, de las cantidades, de sus precios y de su destino. El pedido enviado por el Comprador es irrevocable.

A.4.- La venta deberá considerarse perfeccionada desde el momento en que: (a) el Comprador recibe por parte del Vendedor una confirmación -escrita a través de e-mail, fax u otros medios telemáticos- conforme con los términos y según las condiciones del pedido; o (b) en caso de confirmación enviada por el Vendedor que contenga condiciones diferentes de las del pedido enviado por el Comprador cuando este las acepte por escrito o, en todo caso, no las cuestione dentro de los 7 (siete) días sucesivos a la recepción; o (c) en ausencia de confirmación escrita por el Vendedor, en el momento en que los productos serán entregados y serán cargados por el Comprador.

#### B.- PRECIOS

B.1.- Salvo acuerdo escrito en contrario, los precios de venta acordados de manera puntual se entienden al neto en efectivo y para entrega en el establecimiento del Vendedor indicado en la confirmación del pedido.

#### C.- CARACTERÍSTICAS DE LOS PRODUCTOS

C.1.- El Comprador declara haber visto y atenderse al contenido de la siguiente documentación publicada en el sitio internet de la empresa: 1) Manual de Colocación, Uso, Limpieza y Mantenimiento y 2) Fichas Técnicas.

C.2. Dada la intrínseca variabilidad del producto cerámico, las características de las muestras y/o modelos enviados anteriormente por el Vendedor al Comprador deben ser considerados como aproximados y no vinculantes.

C.3. Salvo especificaciones requeridas, a acordar antes de la confirmación del pedido, el Vendedor no garantiza que el pedido de un artículo en particular sea despachado como un mismo lote de producción.

#### D.- PLAZOS DE ENTREGA

D.1.- Los plazos de entrega deben entenderse como aproximados y su prórroga no puede devengar a favor del Comprador ningún derecho a solicitar indemnizaciones, sin excepciones posibles.

D.2.- Si, una vez transcurridos 10 (diez) días desde la fecha de aviso de estar lista la mercancía, el Comprador no retira el material, el Vendedor se reserva de establecer discrecionalmente un nuevo plazo de entrega.

#### E.- ENTREGA Y TRANSPORTE

E.1.- La eventual variación de lugar de destino de los productos, señalando uno diferente respecto de aquel acordado en la confirmación de pedido, debe ser comunicada por el Comprador por escrito dentro del plazo máximo taxativo del penúltimo día previo al retiro desde el establecimiento del Vendedor. El Vendedor se reserva la facultad de no aceptar el cambio de lugar de destino de los Productos. En caso de verificarse que el destino efectivo del producto sea diferente de aquel declarado por el Comprador, el Vendedor se reserva la facultad de suspender la realización de los suministros en curso y/o de rescindir los contratos en curso sin que el Comprador pueda pedir rescamientos directos y /o indirectos de ningún tipo.

E.2.- Salvo acuerdo en contrario, el suministro de la mercancía se entiende ex Works (EXW según Incoterms 2010) y ello también cuando se acuerde que el transporte o parte de él quede a cargo del Vendedor, según mandato del Comprador. En todo caso, los riesgos se transfieren al Comprador a más tardar con la entrega al primer transportador.

E.3.- Como confirmación del hecho de que el Vendedor es ajeno al contrato de transporte, el mismo no podrá ser indicado como “shipper” en la póliza de carga. La comunicación del peso bruto del contenedor al transportista no comporta ninguna asunción de responsabilidad de parte del Vendedor para los fines del Convenio SOLAS (Safety Of Life At Sea). De ninguna manera la antedicha comunicación podrá ser considerada como VGM (Verified Gross Mass).

E.4.- El Comprador se compromete a fin de que el vehículo enviado al establecimiento del Vendedor sea idóneo para cargar considerando la naturaleza de los productos. En caso de que el vehículo que se presenta comporte significativas dificultades para las operaciones de carga, el Vendedor se reserva el derecho a incluir una recarga del 4 % del valor de los productos a cobertura de los mayores costos logísticos. Si el vehículo enviado para retirar la mercancía no es absolutamente idóneo, el Vendedor se reserva la facultad de negar las operaciones de carga sin que nada pueda requerir el Comprador a título de resarcimiento por todo eventual costo directo y/o indirecto que de ello pueda derivar.

E.5.- Es tarea del Comprador encargar al transportista controlar los productos antes de cargarlos; eventuales observaciones sobre la integridad de los embalajes y la exactitud de las cantidades cargadas, así como aquellas puestas en el documento de transporte, deben ser presentadas por el transportista en el momento de cargar. Estas observaciones deben ser reproducidas en todas las copias de los documentos de transporte; de lo contrario los productos cargados se entienden íntegros y completos. De ello deriva que el Vendedor no se asume ninguna responsabilidad con referencia a faltas o daños en los productos no señalados por el transportista.

E.6.- Asimismo, es responsabilidad del Comprador encargar al transportista verificar las modalidades y la estabilidad de la carga sobre el vehículo a fin de que durante el transporte no se produzcan roturas y que sean respetadas todas las disposiciones sobre seguridad relativas a la circulación por vías públicas.

#### F.- PAGOS

F.1.- Toda obligación de pago debe ser cumplida en la sede legal del Vendedor. Eventuales pagos a agentes, representantes o auxiliares de comercio no se entienden efectuadas mientras las respectivas sumas no lleguen a poder del Vendedor.

F.2.- Queda prohibido para el Comprador cumplir su propia obligación mediante pagos provenientes de países que no sean su propio país de residencia si se trata de países que no garantizan adecuado intercambio de informaciones con Italia. En caso de violación de esta prohibición, el Vendedor tiene facultad de rescindir el contrato por justa causa sin que el Comprador pueda pretender derecho de obtener algún resarcimiento por eventual daño sufrido.

F.3.- Eventuales gastos de sello fiscal y de cobro de letras de cambio y efectos comerciales quedan a cargo del Comprador. En caso de incumplimiento, incluso solo parcial, del día fijado para el pago, se devengarán a favor del Vendedor los intereses de mora en la medida prevista por el Decreto Leg. nº 231 del 09/10/2002.

F.4.- Salvo acuerdos escritos que lo contradigan, el Comprador se compromete a no compensar ningún crédito de cualquier forma creado respecto del Vendedor.

#### G.- RECLAMOS

G.1.- Al recibir los productos, el Comprador deberá someterlos a cuidadoso control a través de un examen visual efectuado conforme según las indicaciones del punto 7.4 de las normas UNI EN ISO 10545-2.

G.2.- La instalación y colocación de los productos deberá efectuarse respetando escrupulosamente las recomendaciones inherentes a las actividades a realizar antes y durante la colocación, indicadas en el documento 1) Manual de Colocación, Uso, Limpieza y Mantenimiento publicado en el sitio internet del Vendedor y en el embalaje del producto y/o en el interior del mismo. No son considerados como vicios del producto aquellos generados por una errónea instalaciòn y error/falta de mantenimiento (intervenciones diferentes de las instrucciones proporcionadas en el 1) Manual de Colocación, Uso, Limpieza y Mantenimiento), por un uso inapropiado y/o por el normal desgaste con el pasar del tiempo.

G.3.- Sin perjuicio de los límites de aceptabilidad previstos por la norma internacional EN 14411 (ISO 13006), las partes reconocen como vicios evidentes los defectos de los productos constatables ya en el momento de su recepción y tales que impidan el uso previsto del material o reduzcan de modo apreciable su valor. Forman parte de esta categoría los defectos precisamente establecidos en el documento 1) Manual de Colocación, Limpieza y Mantenimiento publicado en el sitio internet del Vendedor. A título solo de ejemplo, se reconocen como vicios evidentes los defectos superficiales, los defectos de decoración, de lapeado/pulido, de calibre, de planitud, de ortogonalidad-rectilineidad, de espesor, las grietas, los astillados, las variaciones

de tono, los tonos mezclados y los productos que presentan problemas de cortes/escamas.

G.4.- En caso de que el Comprador observe la presencia de vicios evidentes, deberá presentar reclamo al Vendedor por escrito, so pena de extinción del derecho, dentro de los 8 (ocho) días sucesivos a la recepción y mantener a disposición del Vendedor la partida completa de material. El reclamo deberá indicar los datos de facturación y una precisa descripción del vicio observado incluyendo, en lo posible, imágenes fotográficas. En caso de que el reclamo debiera demostrarse luego ser infundado, el Comprador se declara dispuesto a resarcir al Vendedor por los gastos efectuados para realizar la respectiva constatación en situ (peritajes, viajes, etc.).

G.5.- Los vicios ocultos deberán ser notificados al Vendedor mediante carta certificada con aviso de recibo, bajo pena de caducidad de la garantía, dentro de los 8 (ocho) días a contar de la fecha del descubrimiento del defecto.

G.6.- La acción del Comprador tendiente a hacer valer la garantía por vicios prescribe, en todo caso, en el plazo de 12 (doce) meses a contar de la entrega de los productos.

#### H.- GARANTÍA POR VICIOS

H.1.- La garantía del Vendedor se entiende limitada solo a los productos de primera selección y no a los productos de segunda o tercera selección o de partidas de ocasión con precios o descuentos especiales cuando ello se encuentre debidamente señalados en nota en la confirmación del pedido.

H.2. El Vendedor no garantiza la idoneidad de los productos para usos particulares, sino solo las características técnicas publicadas en el sitio internet, documento 2) Fichas Técnicas. La indicación de uso, incluso cuando es presentada por el Vendedor en catálogos y manuales, debe considerarse solo como genérica. Sobre la base de las características técnicas señaladas en las 2) Fichas Técnicas, es siempre tarea del proyectista evaluar la idoneidad del producto en función de las condiciones específicas de uso en consideración de las solicitudes y de las variables que pueden operar en el ambiente de destino, alterando sus características; a título de ejemplo: la intensidad del tráfico, la calidad del tráfico (tránsito en presencia de arena, de detritos, etc.), las eventuales condiciones climáticas adversas y cualquier otro factor aleatorio al que puede quedar expuesto el material.

H.3.- En caso de comprobarse que el producto manifieste vicios evidentes, tal como han sido definidos en la letra G nº. 3, el Vendedor procederá a sustituir el producto defectuoso con otro con características iguales o superiores o, en el caso de que ello no sea posible, deberá efectuar una congrua reducción del precio. Como alternativa, el Comprador tendrá derecho, previa devolución de los productos viciados, al reembolso del precio pagado, agregándose el costo del transporte, con exclusión del resarcimiento de todo otro daño, directo y/o indirecto.

H.4. La garantía del Vendedor debe considerarse excluida en caso de que el producto que presenta vicios evidentes (total o parcialmente) haya sido utilizado y/o, en cualquier caso, transformado, debiéndose estimar que de tal modo el Comprador (o su cliente) ha expresado la voluntad de aceptarlo en el estado en que se encuentra.

H.5 En los casos en que quede comprobado que el producto presenta vicios ocultos, la garantía del Vendedor queda limitada a la sustitución del material con otro de características iguales o superiores y, allí donde ello no sea posible, al reembolso del precio pagado, agregándose el costo del transporte. En todo caso, la garantía del Vendedor por cada daño directo y/o indirecto de cualquier forma derivado de producto defectuoso, debe entenderse limitada a una suma que no podrá superar el doble del precio de venta aplicado por el Vendedor, con referencia solo a la parte defectuosa del suministro.

H.6.- En caso de que el Comprador revenda el producto a terceros protegidos por el código del consumo (D.L. nº. 206/2005), será responsable de las condiciones practicadas si son diferentes de aquellas aquí señaladas y deberá comprobarse que los derechos del consumidor sean ejercidos con aplicación de los remedios y de los términos fijados por el antedicho código. En caso de subsistir las condiciones, el derecho de devolución y/o, en todo caso, de compensación a favor del Comprador respecto del Vendedor/productor, no podrán excederse las exenciones ni límites establecido en la letra G del nº. 1 y en la letra H nº. 5.

#### I. CLÁUSULAS SOLVE ET REPETE Y RESOLUTIVAS

I.1.- De conformidad con lo dispuesto por el art. 1462 del Código Civil, por ningún motivo, incluidos supuestos vicios o defectos del material, el Comprador podrá suspender o retardar el pago del material retirado, sin perjuicio obviamente de la facultad de restitución cuando pueda demostrar que ha pagado indebidamente.

I.2.- En el caso de cambiar las condiciones patrimoniales del Comprador o de falta de pago incluso parcial de productos ya suministrados, el Vendedor podrá suspender la realización de los suministros en curso y/o rescindir los contratos en curso sin que el Comprador pueda reivindicar resarcimientos directos ni indirectos de cualquier clase.

#### L.- PACTO DE RESERVADO DOMINIO

L.1.- Mientras el Comprador no haya efectuado el pago integral del precio, los productos objeto del suministro seguirán siendo de propiedad del Vendedor.

L.2.- Durante el período antedicho, el Comprador asumirá las obligaciones y las responsabilidades del depositario y no podrá enajenar, entregar en uso ni dejar retener o embargar los productos sin declarar la propiedad del Vendedor y enviar inmediatamente aviso con carta certificada con aviso de recibo.

#### M.- FUERZA MAYOR

M.1.- Cada parte podrá suspender la ejecución de sus obligaciones contractuales cuando esa ejecución se haga imposible u objetivamente demasiado onerosa por impedimento imprevisible independiente de su voluntad, tal como por ejemplo: huelga, boicot, bloqueo, incendio, guerra (declarada o no declarada), guerra civil, rebelión y revolución, requisición, embargo, interrupción de energía, rotura extraordinaria de maquinaria, retraso en la entrega de componentes o materias primas.

M.2.- La parte que desee valerse de la presente cláusula deberá comunicar de inmediato por escrito a la otra parte el verificarse y el cese de las circunstancias de fuerza mayor.

M.3.- En caso de que la suspensión causada por fuerza mayor dure más de 60 (sesenta) días, cada una de las partes tendrá derechos de rescindir el presente contrato, con preaviso de 10 (diez) días, a comunicar a la otra parte por escrito.

#### N.- OBLIGACIÓN DE CONFIDENCIALIDAD

N.1.- El Comprador debe mantener la más absoluta confidencialidad respecto de todas las informaciones de carácter técnico (tales como, solo como ejemplo, diseños, prospectos, documentaciones, fórmulas y correspondencia) y de carácter comercial (incluidas las condiciones contractuales, los precios de compra, las condiciones de pago, etc.) obtenidas a propósito de la ejecución del presente contrato.

N.2.- La obligación de confidencialidad es válida por toda la duración del contrato, así como por el periodo sucesivo a su ejecución.

N.3.- En cualquier caso de inobservancia de la obligación de confidencialidad, la parte incumplidora deberá indemnizar a la otra por todos los daños que de ello puedan derivar.

#### O.- MARCAS Y SIGNOS DISTINTIVOS DEL VENDEDOR

O.1.- Queda severamente prohibido el uso a través de cualquier medio (tales como, solo a título de ejemplos no exhaustivos: prensa, videos, radio, internet, social media, plataformas de mensajería instantánea o VoIP, etc.) de las marcas, de los modelos ornamentales y de las obras del ingenio en general que constituyan propiedad intelectual del Vendedor y ello en cualquier forma o modo de expresión (tales como, solo a título de ejemplos no exhaustivos: imágenes, fotos, dibujos, videos, figuras, estructuras, etc.).

Cualquier excepción a esta prohibición, incluso solo parcial, deberá ser autorizada caso por caso por escrito por la dirección general del Vendedor.

#### P.- IDIOMA DEL CONTRATO, LEY APLICABLE, JURISDICCIÓN Y COMPETENCIA

P.1.- El contrato y las presentes condiciones son redactados en lengua italiana, la cual prevalecerá en caso de divergencia con las traducciones en otros idiomas.

P.2.- La resolución de cualquier controversia de cualquier forma relativa al suministro queda sujeta a la ley y a la jurisdicción del Estado Italiano y la competencia territorial es asignada de forma exclusiva al Tribunal de Módena, en cuya circunscripción el Vendedor tiene su domicilio legal.



## IT\_

Ceramiche Keope raccomanda l'utilizzo delle lastre in spessore 6 mm per le sole applicazioni in ambito residenziale, commerciale a traffico leggero e comunque in contesti ove non vi sia passaggio di carichi puntuali pesanti o transito di carrelli a ruote dure. Oltre all'utilizzo a rivestimento è inoltre possibile posarle su pavimenti preesistenti in marmo, pietra naturale o ceramica, senza la necessità di demolire la pavimentazione sottostante.

Per l'applicazione su massetto Ceramiche Keope consiglia l'utilizzo del gres porcellanato in spessore tradizionale.

Per una posa ad opera d'arte, consultare Consigli di posa, pulizia e manutenzione al link **keope.com**

## IT\_

Ceramiche Keope si riserva la facoltà di apportare variazioni ai prodotti illustrati in questo catalogo per necessità produttive o al fine di migliorarne la qualità. I campioni sono puramente indicativi. Gli imballaggi e pesi riportati possono variare per necessità produttive. Consultare gli uffici commerciali al momento dell'ordine.

## IT\_

Ceramiche Keope si riserva la facoltà di apportare variazioni ai prodotti illustrati in questo catalogo per necessità produttive o al fine di migliorarne la qualità. I campioni sono puramente indicativi. Gli imballaggi e pesi riportati possono variare per necessità produttive. Consultare gli uffici commerciali al momento dell'ordine.

## FR\_

*Ceramiche Keope conseille de n'utiliser les plaques d'une épaisseur de 6 mm que pour des applications à caractère résidentiel ou commercial avec circulation modérée et, plus généralement, uniquement dans des situations qui ne prévoient pas le passage ponctuel de charges lourdes, ni le transit de chariots à roues dures. Outre leur utilisation pour le revêtement de parois, il est également possible de les poser sur des sols anciens en marbre, en pierres naturelles ou en carrelage, c'est-à-dire sans nécessité de démolir le revêtement de sol précédent.*

*Pour l'application sur une chape, Ceramiche Keope conseille d'utiliser un grès cérame de l'épaisseur habituelle.*

*Pour une pose selon les règles de l'art, veuillez consulter nos Conseils de pose, nettoyage et entretien disponibles sur le lien **keope.com***

## FR\_

*Ceramiche Keope se réserve la faculté d'apporter des variations aux produits illustrés dans ce catalogue dans un but inhérent à la production ou afin d'en améliorer la qualité. Les échantillons sont purement indicatifs. Les emballages et les poids reportés peuvent varier pour des nécessités de production. Consulter les bureaux commerciaux au moment de la commande.*

## EN\_

*Ceramiche Keope recommends the use of 6 mm thick tiles only for residential and low traffic commercial applications. These tiles are not recommended for applications involving the transit of heavy loads or hard-wheeled trolleys. 6 mm thick tiles can be installed as wall coverings and as floor coverings over existing marble, stone or ceramic floors without having to demolish the previous floor.*

*Ceramiche Keope recommends the use of porcelain tiles of conventional thickness for applications over screed.*

*To ensure a perfect finish, consult the recommendations for laying, cleaning and maintenance available from **keope.com***

## EN\_

*Ceramiche Keope reserves the right to vary the products illustrated in this catalogue for production purposes or in order to improve quality. Samples are purely indicative. Packaging and weights shown may be varied in line with production requirements. Check with the sales department at the time of order.*

## EN\_

Ceramiche Keope si riserva la facoltà di apportare variazioni ai prodotti illustrati in questo catalogo per necessità produttive o al fine di migliorarne la qualità. I campioni sono puramente indicativi. Gli imballaggi e pesi riportati possono variare per necessità produttive. Consultare gli uffici commerciali al momento dell'ordine.

## DE\_

*Ceramiche Keope empfiehlt die Verlegung der 6-mm-starken Platten nur für den Wohn- und Gewerbebereich mit leichtem Verkehr. Das Produkt sollte nur in Umgebungen zur Anwendung kommen, in denen keine schweren Punktlasten entstehen und keine Wagen mit harten Rädern durchfahren. Neben der Verwendung als Wandbelag eignet sich das Material auch für die Verlegung auf bestehenden Marmor-, Naturstein- oder Keramikböden, ohne dass der darunter liegende Bodenbelag abgerissen werden muss.*

*Für die Anwendung auf Estrichen empfiehlt Ceramiche Keope die Verwendung von Feinsteinzeug mit traditioneller Stärke.*

*Für eine korrekte Verlegung sollten die Verlege-, Reinigungs- und Wartungsanweisungen unter **keope.com** beachtet werden.*

## DE\_

*Ceramiche Keope behält sich das Recht vor, Änderungen an den Produkten aus diesem Katalog aufgrund von Produktionsnotwendigkeiten vorzunehmen, oder um die Qualität zu verbessern. Die Muster dienen allein zur Orientierung und sind nicht verbindlich. Die Verpackung und die angegebenen Gewichte können durch Produktionsanforderungen variieren. Wenden Sie sich bitte zur Bestellung an unsere Vertriebsabteilung.*

## ES\_

*Ceramiche Keope recomienda utilizar baldosas de 6 mm de espesor para uso en zonas residenciales, zonas comerciales con poco tráfico y zonas por las que no circulen cargas pesadas o carros de ruedas duras, ni siquiera de forma provisional. Además de utilizarse como revestimiento, pueden instalarse sobre suelos previamente existentes de mármol, piedra natural o cerámica sin la necesidad de quitarlos.*

*Para aplicaciones sobre solera, Ceramiche Keope recomienda utilizar el gres porcelánico de espesor normal.*

*Para una colocación perfecta, consulte los consejos de colocación, limpieza y mantenimiento en el enlace **keope.com***

## ES\_

*Ceramiche Keope se reserva la facultad de aportar variaciones a los productos ilustrados en este catálogo por necesidades de producción o con el fin de mejorar su calidad. Las muestras son puramente indicativas. Los embalajes y pesos indicados podrán variar por necesidades de producción. Consultar con los departamentos comerciales al realizar el pedido.*



---

**HEADQUARTER** via statale 467, 21  
42013 Casalgrande (RE) - Italy  
**FACTORY** via canale, 67  
42013 Casalgrande (RE) - Italy  
**WAREHOUSE** via dell'industria, 1  
42013 Casalgrande (RE) - Italy

---

**PHONE** +39 0522 997511  
**FAX** +39 0522 997544 (OT) - 545 (IT)  
**ADMIN. FAX** +39 0522 997413

---

[info@keope.com](mailto:info@keope.com)  
[keope.com](http://keope.com)

#### **IT\_**

Ceramiche Keope si riserva la facoltà di apportare variazioni ai prodotti illustrati in questo catalogo per necessità produttive o al fine di migliorarne la qualità. I campioni e le immagini sono puramente indicativi. Gli imballaggi e pesi riportati possono variare per necessità produttive. Consultare gli uffici commerciali al momento dell'ordine.

#### **EN\_**

*Ceramiche Keope reserves the right to vary the products illustrated in this catalogue for production purposes or in order to improve quality. Samples and images are purely indicative. Packaging and weights shown may be varied in line with production requirements. Check with the sales department at the time of order.*

